



# Scottish Water

Trusted to serve Scotland

## Sewers for Scotland v4.0



**Trusted**  
Putting  
customers first



**Serving**  
Delivering for  
Scotland 24/7





# **Sewers for Scotland - A technical specification for the design and construction of sewerage infrastructure**

Version 4.0 – October 2018

## Copyright

Copyright of this document is owned by Scottish Water. The document may not be copied or reproduced in any way.

This document and the intellectual property rights in it belong to Scottish Water and except where you are specifically licensed to use this document, you have no right to re-use it. Disclosure of this document under freedom of information does not change the position on (i) ownership and (ii) re-use.

This document has been produced by Scottish Water and WRc plc.

Copyright © Scottish Water

### Feedback Arrangements:

Technical enquiries should be referred to Scottish Water Technical Standards Team  
Buchanan Gate Business Park, Cumbernauld Road, Stepps, G33 6FB.

Email – [standardsinfoline@scottishwater.co.uk](mailto:standardsinfoline@scottishwater.co.uk)



## Record of Changes and Amendments

Amendment Number	Amendment Date	Document Section/Clause Reference Number	Document Section/Clause Header	Brief Summary of Change	Document Version Number
1	October 2018	2.9.8.6	Ponds – Operation & Maintenance	Reference to tanker size	4.0
2	October 2018	2.10.7.3	Basins –Operation & Maintenance	Reference to tanker size	4.0
3	October 2018	2.11&12	Swales	Section on Swales and piped Filter trenches added	4.0
4	October 2018	2.13	Underground storage	Guidance on underground storage	4.0
5	October 2018	2.18.10	Connections	Position of DC to allow direct connection to Sewer	4.0
6	October 2018	2.20.12	Design of Manholes	Use of Composite Manholes Covers	4.0
7	October 2018	2.20.13	Design of Manholes	Minimum width of benching for preformed and traditional bases	4.0
8	October 2018	2.22.2	Min Sewer Size and Materials	Materials referenced	4.0
9	October 2018	2.22.2	Min Sewer Size and Materials	Structured Walled plastic increased to 600mm	4.0
10	October 2018	2.22.3	Min Sewer Size and Materials	Concrete or Structurally reinforced polyethylene pipes > 600mm dia	4.0
11	October 2018	2.22.4	Min Sewer Size and Materials	Integrated manholes on pipework >1200	4.0
12	October 2018	2.23.1	Hydraulic Design	Design flow increased to 4300 litres per unit dwelling per 24 hours	4.0
13	October 2018	Appendix XI &XII	Chamber Access Strategy	Strategy added from Spec 302	4.0
14	October 2018	Appendix XIII	Tree planting guide	Tree planting guide added	4.0



# FOREWORD

The 4th Edition of Sewers for Scotland takes account of changes to technical standards and new additions to material selection, and provides improved clarity on Scottish Water's requirements in terms of specification for the design, construction and vesting of new water infrastructure assets.

This Specification sits within Scottish Water's hierarchy of policy, procedure and general standards and specification document management system, and is intended to provide developers or other parties involved with supporting new development in Scotland with the technical standards for the development of sewerage infrastructure.

In reviewing and updating this Specification we understand that supporting new development and building homes has a national aspect and we have worked closely with the WRc plc to ensure, where appropriate, there is a close alignment with the latest 'Sewers for Adoption', as applied to the English and Welsh water companies. There are, however, areas where infrastructure in Scotland reflects policy and legislative requirements and these have been included in this Specification.

In collaboration with the Standards Board and other partners, agreement has been reached to have Sewers for Scotland, 4th edition, made available in electronic format via Scottish Water's document management portals. This will enable improved industry-wide accessibility and the mechanism for dynamic review, updates for continual improvements in policy or technical standards. Any addendums, updates, etc., will be published on Scottish Water's electronic information portals.

Sewers for Scotland is aimed at all developers and their consultants who plan to undertake a development of any size in Scotland. This Specification provides developers with technical standards applicable to sewers, pumping stations and sustainable drainage systems "SUDS" which will vest in Scottish Water. Scottish Water provides supplementary documents which further clarify the process of vesting of new assets and should be read in conjunction with Sewers for Scotland. These are available at [www.scottishwater.co.uk](http://www.scottishwater.co.uk).

The provision and ongoing maintenance of public drainage systems in urban areas is crucial to the mitigation of flooding and the protection of public health and the environment. This is a major step forward in delivering sustainable drainage which needs the partnership of all those engaged in urban development and its infrastructure to deliver integrated solutions.

Small and medium-sized pumping stations serving individual developments are a significant part of the sewerage infrastructure of Scotland. This Specification now provides improved options and technical solutions to ensure such assets are constructed to a suitable standard and transferred to Scottish Water in accordance with the new vesting standards.

## **CONTENTS**

<b>FOREWORD</b>	<b>I</b>
<b>SECTION 2C – SEWERAGE DESIGN</b>	<b>61</b>
<b>SECTION 2D – PUMPING</b>	<b>79</b>
<b>STATION DESIGN</b>	<b>79</b>
<b>PART 3 – MECHANICAL &amp; ELECTRICAL SPECIFICATION FOR PUMPING STATIONS</b>	<b>107</b>
<b>SECTION 3A – PUMP SPECIFICATION</b>	<b>108</b>
<b>SECTION 3B – MOTOR SPECIFICATION</b>	<b>116</b>
<b>SECTION 3C – ELECTRICAL SPECIFICATION</b>	<b>119</b>
<b>SECTION 3D – VALVE SPECIFICATION</b>	<b>146</b>
<b>PART 4 - CIVIL ENGINEERING SPECIFICATION</b>	<b>148</b>
<b>APPENDICES</b>	<b>186</b>
<b>APPENDIX I – PUBLICATIONS</b>	<b>187</b>
<b>APPENDIX II – BRITISH STANDARDS INCLUDING EUROPEAN STANDARDS, CODES OF PRACTICE AND WATER INDUSTRY SPECIFICATIONS</b>	<b>191</b>
<b>APPENDIX III – STANDARD SYMBOLS FOR USE ON DRAWINGS</b>	<b>201</b>
<b>APPENDIX IV – PARLIAMENTARY ACTS AND REGULATIONS (TO WHICH REFERENCE IS MADE IN OR ARE RELEVANT TO THIS SPECIFICATION)</b>	<b>202</b>
<b>APPENDIX V – MODEL FORMS OF AGREEMENT</b>	<b>204</b>
<b>APPENDIX VI – GUIDANCE FOR DEVELOPERS ON VESTING OF FIRST TIME DISCRETE SEWERAGE SYSTEMS</b>	<b>216</b>

<b>APPENDIX VII – DETERMINATION OF GREENFIELD RUNOFF PEAK FLOWS</b>	<b>221</b>
<b>APPENDIX VIII - RESPONSIBILITIES FOR MANAGING FLOOD RISK IN SCOTLAND</b>	<b>224</b>
<b>APPENDIX IX – DSEAR PRELIMINARY ASSESSMENT RECORD</b>	<b>227</b>
<b>APPENDIX X - GLOSSARY OF TERMS AND ABBREVIATIONS</b>	<b>228</b>
<b>APPENDIX XI – CHAMBER ACCESS</b>	<b>233</b>
<b>APPENDIX XII – CHAMBER ACCESS STRATEGY AND GUIDANCE</b>	<b>236</b>
<b>APPENDIX XIII – TREE PLANTING</b>	<b>241</b>

# PART 1 – GENERAL

## 1.1 APPLICATION

1. This document states Scottish Water's technical specification for the design and construction of sewerage infrastructure (including foul and statutory surface water sewers) for housing and industrial/commercial developments, which is to vest in Scottish Water. This Specification covers new sewerage infrastructure only and should not be used as a definitive design manual for all sewerage-related construction such as rehabilitation.

2. This Specification is applicable to single developments. Where multiple developments are planned, they would need to be assessed on an individual basis and in consultation with SEPA, the Local Authorities, Scottish Natural Heritage and any other stakeholder involved in the production and development of the surface water management plan.

3. Scottish Water is developing a suite of "standard products" as a design and procurement reference which defines Scottish Water's requirements for vested assets. The detailed design for "standard products" will be incorporated in to a Scottish Water product catalogue for use by the supply chain and made available to all designers, etc., involved in delivering compliant infrastructure or associated pumping plant, in accordance with the full suite of Scottish Water's standards and specification documentation.

## 1.2 STATUTORY DUTIES

1. The Sewerage (Scotland) Act 1968 as amended requires Scottish Water to effectively drain its area of domestic sewage, surface water runoff from roofs and paved areas within the curtilage of premises, and trade effluent.

Note: Scottish Water is not obliged to do any of the above which is not practicable at reasonable cost.

2. Scottish Water has no duty to drain roads, footpaths and footways outwith the curtilage of premises or to drain groundwater or accept land drainage connections. Where Scottish Water agrees to drain road water into their surface water system, the Roads Authority shall be required to enter into an agreement under Section 7 of the Sewerage (Scotland) Act 1968. This agreement shall specify the terms and conditions agreed between both parties for the provision, management and future maintenance of the system.

Note: Provision for the disposal of road water and other runoff remains the responsibility of the developer.

3. Scottish Water provides core water and wastewater services to businesses through its appointed licensed provider (retailer).

4. The Operational Code sets out the rules on how Scottish Water and licensed providers will operate in the new market. Developers shall have to appoint a licensed provider to process and submit applications for any non-household development or a development which includes a non-household element. Scottish Water cannot process such applications directly with developers.

Note: Where references are made in this document to developers, care should be taken to consider the role of licensed providers. Further detailed guidance relating to this process is available in Scottish Water's 'A Developers Guide for Obtaining New Water and Waste Water Services'.

5. Scottish Water and the developer each have responsibilities in relation to the provision of new sewerage assets. The Provision of Water and Sewerage Services (Reasonable Cost) (Scotland)

Regulations 2015 sets out these requirements and the contributions that Scottish Water is required to provide to developers for publicly 'vestable' systems.

6. Scottish Water has a duty under the Sewerage (Scotland) Act 1968 to intimate to any developer who gives notice of proposals to connect drains or private sewers with the sewers or sewage treatment works of Scottish Water, its decision in relation to these proposals including the conditions attached to that decision. This document provides consistency of application of these conditions and sets out how developers may comply with the standards for design and construction of new sewerage infrastructure.

7. The responsibilities of Scottish Water and others for the management of flood risk in Scotland are described in Appendix VIII

### **1.3 GENERAL PRINCIPLES**

1. This section shall be read in conjunction with Scottish Water's 'A Developers Guide for Obtaining New Water and Waste Water Services' (available from [www.scottishwater.co.uk](http://www.scottishwater.co.uk)) which sets out the overall process by which the developer can obtain provision and vesting of site infrastructure.

2. The developer shall consult with Scottish Water at the earliest opportunity on all technical matters regarding the provision of sewerage infrastructure for proposed developments to agree design principles and any site-specific requirements.

3. The specific process for the vesting of foul and statutory surface water sewers is set out in Scottish Water's vesting standards.

4. The specific process for the vesting of pumping stations is available from Scottish Water.

5. Where the developer fails to comply with this technical Specification, Scottish Water will not allow the private sewer system to be connected to its sewerage infrastructure and wastewater treatment works.

6. The developer shall undertake the design and preparation of drawings in accordance with the principles outlined in Part 2.

7. Prior to submitting an application, the developer shall notify Scottish Water of any contaminated land which is to remain within the site boundary. Failure to disclose this information may delay the application process and may result ultimately in its refusal to vest the sewers and/or surface water drainage systems (including SUDS). Scottish Water reserves the right to reject proposals with contaminated and beneath and/or surrounding assets which are to be vested. The following information shall be provided:

- a) existing distribution of contaminated material (i.e., location, depth, etc.);
- b) type and concentration of contamination (i.e., by laboratory assessment);
- c) significance of contamination (e.g., comparison to mandatory exceedance levels);
- d) proposal mitigation measures (i.e., method statement, drawings showing remediation details, etc.).

8. If the contaminated material is located beneath and/or is surrounding assets which are to be vested with Scottish Water, then detailed drawings showing the protective measures shall be provided. Furthermore, the health and safety implications shall be included on the drawings and in the O&M manual (if applicable). Such information shall include, but not be limited to:

- a) distribution of material (i.e., location, depth, etc.);
- b) type and concentration of material;
- c) design risk assessment (covering Scottish Water operations during the lifetime of the asset, including decommissioning).

9. Formal Application to Connect shall be made using the standard application form available from Scottish Water. This shall be accompanied by:

- a) drawings prepared in accordance with Appendix III and in metric units;
- b) design calculations;
- c) clear evidence in terms of the Construction (Design and Management) Regulations that due cognisance has been taken of the requirement for Scottish Water's staff to carry out regular inspections on site;
- d) design risk assessment for proposed SUD systems;
- e) confirmation of formal verification that the development can be served.

### **Liaison in Planning**

10. The developer shall liaise with the following stakeholders (and any other potential stakeholders) who may be involved in the development process:

- a) Local Authority as part of their flood prevention duties and in their capacities as – Local Planning Authority, Flood Prevention Authority, Roads Authority and Building Standards;
- b) Scottish Environment Protection Agency (SEPA);
- c) land owners and tenants regarding land drainage;
- d) Scottish Water;
- e) the Crown, Network Rail, Airport Authorities, MOD, etc., where special permission may be required for land owned by them;
- f) the relevant Navigation Authority for permission to discharge into controlled waters.

11. The SUDSWP document 'Drainage Assessment: A Guide for Scotland' requires that a developer undertakes and submits a Drainage Assessment (DA) to the local Planning Authority with their planning applications.

12. For all developments and at an early stage before a Drainage Assessment (DA) is submitted, the developer shall consult with Scottish Water on appropriate SUD system design and the practical aspects of servicing the development.

13. The developer shall agree the Drainage Assessment (DA) with the local Planning Authority and stakeholder organisations prior to submitting a formal application of their design to Scottish Water.

### **Agreements**

14. When road runoff is to be accepted into Scottish Water's surface water system, then the developer shall assist Scottish Water and the Roads Authority to enter into an agreement under Section 7 of the Sewerage (Scotland) Act 1968.

15. The developer shall carry out all consultation with respect to the serving of notices on the other public utilities and the Roads Authority, and shall consult with SEPA (where appropriate) and any other relevant bodies. The developer shall not agree to any conditions relating to discharge consent criteria without the prior approval of Scottish Water.

16. In respect of proposed sewers to be constructed in land which the developer does not already own and occupy, the developer shall (unless otherwise agreed in writing by Scottish Water) apply to Scottish Water to authorise him under Section 3A of the Sewerage (Scotland) Act 1968 to construct a sewer in a road or land which the developer does not already own and occupy. The developer shall demonstrate through records submitted to Scottish Water that detailed negotiations have been undertaken with land owners and occupiers prior to submitting a request under Section 3A of the Sewerage (Scotland) Act 1968.

17. The developer shall serve the appropriate notice in respect of proposed sewers on owners and occupiers. Resolution of any objections, all negotiations, compensation arrangements, etc., shall be the responsibility of the developer, who shall comply with the standard terms and conditions



contained in Scottish Water's Section 3A Authorisation (Appendix V), together with such further conditions as may be relevant in any given case. Copies of all notices and relative notice plans served by the developer, affected owners/occupiers, or the Sheriff's consent shall require to be passed to Scottish Water before work starts on site. Written notice of intention to carry out the sewer construction works shall also be given by the developer to the relevant Planning Authority, together with a copy of the notice plans, not later than 28 days prior to the commencement of any work. Such private sewers shall only become public sewers once Scottish Water so determines. Such private sewers, once completed to the satisfaction of Scottish Water shall normally be taken over by Scottish Water as public sewers under vesting agreements.

18. In exceptional circumstances, where the developer can provide evidence that the notice procedure is not possible and Scottish Water has consented, the developer shall obtain at his own expense all and any necessary permissions and/or wayleaves. This consent and a Deed of Servitude will always be required where, exceptionally, Scottish Water has agreed that the sewer may be laid in land owned by the developer which will not become public. All wayleaves shall be in accordance with the Style Deed of Servitude contained in Appendix V. SUD systems shall meet the general design requirements in Part 2, Section B.

## **Construction**

19. The foul sewers, wastewater pumping stations and surface water drainage, including SUD systems, shall be constructed, inspected and tested in accordance with this Specification to Sewers for Scotland, 4<sup>th</sup> Edition, standards. At this time the developer shall apply for a Vesting Certificate. This shall be accompanied by:

- a) two sets of as-built record drawings in electronic format and compatible with AutoCAD 2004 in \*.DWG, \*.tif or \*.DXF format;
- b) closed-circuit television (CCTV) survey of the sewers to facilitate the vesting of the sewers is required to be completed by a qualified contractor in accordance with 4.7.6 of this Specification in CD or DVD format with a hard copy of the written report. The developer is responsible for checking that the CCTV survey shows no defects or debris within the infrastructure to enable the Vesting Certificate to be issued. If defects or debris are visible, no vesting will take place until these are rectified;
- c) Health & Safety File prepared in accordance with the Construction (Design and Management) Regulations.

20. Failure to make an application for a Vesting Certificate shall ultimately mean that the foul sewers, wastewater pumping stations and surface water drainage including SUD systems shall not vest in Scottish Water and no contribution is paid. The developer shall consult Scottish Water's 'A Developers Guide for Obtaining New Water and Waste Water Services' (available from [www.scottishwater.co.uk](http://www.scottishwater.co.uk)) for the current timetable and requirements.

21. The two-year Guarantee Period will start from the issue of the Vesting Certificate. During the Guarantee Period, Scottish Water shall operate and maintain the infrastructure. The developer shall remain responsible for all costs associated with defects or hard blockage.

22. During the final six months of the Guarantee Period, the ponds and basins are to be fully desilted and general husbandry activities completed. At the end of the Guarantee Period, the developer shall apply for the surface water drainage (including the SUD system) to be inspected by Scottish Water.

23. During the Guarantee Period, Scottish Water has the power to inspect any SUD system. Any defects identified in the inspection shall be remedied by the developer at his own expense to the satisfaction of Scottish Water. This shall also be the case should the system be found to be in such a condition that:

- a) it fails to comply with all current legislation/regulations and, in particular, authorisation under the Water Environment (Controlled Activities) (Scotland) Regulations 2011; or

- b) it is open to contamination; and/or
- c) it fails to comply with this Specification; and/or
- d) it is found not to comply with the drawings and design agreed by Scottish Water.

24. Either during or at the end of the Guarantee Period, should the developer fail to carry out the repairs within an agreed period of time, Scottish Water may themselves carry out the work and recover from the developer the expenses reasonably incurred in doing so. The developer will be liable to refund Scottish Water any costs incurred as a consequence of the above circumstances.

25. A satisfactory site audit by Scottish Water for inspecting infrastructure installed does not authorise any activities by the developer which may be in contravention of any enactment or any order, regulation or other instrument made, granted or issued under any enactment, or in contravention of any rule, byelaw or in breach of any agreement or legal rights.

26. In terms of Section 3A(2) of the Sewerage (Scotland) Act 1968, the sewers constructed by the developer shall not vest in Scottish Water through the operation of Section 16(1)(c) of the Sewerage (Scotland) Act 1968 but shall instead remain in the ownership of the developer. The sewers shall only vest in Scottish Water once the developer is issued with a Vesting Certificate. This shall normally be when the foul sewers, wastewater pumping stations and surface water drainage (including SUD systems) have been completed. For large-scale developments, phasing and vesting may be arranged with Scottish Water in bespoke agreements.

27. The developer can apply jointly for the foul sewers and surface water drainage to vest in Scottish Water. For each application, the developer shall forward a CCTV survey of the sewers by a qualified contractor in accordance with 4.7.6 of this Specification in CD or DVD format together with a hard copy of the written report. The developer is responsible for checking that the CCTV survey shows no defects or debris within their sewers. A charge may be levied by Scottish Water for additional CCTV review should the developer fail in their responsibilities. For SUD systems, the developer shall also provide evidence that they have complied with 2.2.5 of this Specification.

28. The developer shall be solely responsible for setting out the sewerage infrastructure.

29. Pipes shall be tested before and after backfilling, and Scottish Water reserves the right to witness these tests. These tests shall fully comply with Part 4 of this Specification. The developer shall keep a record of all tests undertaken and make them available for audit by Scottish Water. Failure to provide records shall delay the issuing of a Vesting Certificate.

30. Ponds shall undergo leakage testing and Scottish Water reserves the right to witness these tests. A minimum of five days' notice shall be given to Scottish Water by the developer.

31. Inspections witnessed by Scottish Water shall be carried out within normal working hours.

### **Guarantee Period and Vesting**

32. During the Guarantee Period, and until construction on the development site is complete, the developer will be liable for meeting all Scottish Water costs associated with damage to any part of the sewers, SUD system and pumping station caused by construction debris, regardless of the source of that debris.

33. Before the Vesting Certificate is issued, all Scottish Water invoices shall be paid by the developer. Any outstanding invoices will be deducted from the Reasonable Cost Contribution.

34. If there are changes to legislation and/or specifications prior to the issue of the Vesting Certificate, the responsibilities for upgrading pumping station equipment will be as follows:

- a) Scottish Water will be responsible for upgrading the pumping station if changes to Scottish Water operational practices lead to the equipment becoming non-compliant;

- b) provided the pumping station complies with the Scottish Water specification current at the time of technical approval, subsequent changes to specifications shall not affect the vesting process.

## **PART 2 – DESIGN**

This Specification is divided into four Sections:

Section A – Design Submissions

Section B – Surface Water Drainage Design

Section C – Sewerage Design

Section D – Pumping station Design

## SECTION 2A – DESIGN SUBMISSIONS

### 2.1 GENERAL

#### Provisions

1. The developer shall provide separate foul and surface water drainage systems for all developments.
2. Individual SUD systems, both public and private, can be used to manage issues of water quantity, water quality and amenity. They work on the following principles:
  - a) managing surface water runoff onsite as near to source as possible;
  - b) slowing down runoff;
  - c) treating it naturally;
  - d) releasing good quality surface water to watercourses or groundwater.

The main aim of any SUD system that is to be vested by Scottish Water, is to convey, treat and discharge SW's statutory surface water to the nearest practical water course.

3. SUDS shall be used as part of a surface water management train that replicates as closely as possible the natural (undeveloped) flow runoff pattern of the site. The management train shall incorporate a hierarchy of techniques:
  - a) source – control of runoff at, or very near, its source likely to be within individual plots, connecting roads, footways and other open spaces;
  - b) pathway – management of the conveyance of surface water across and/or around the site;
  - c) receptor – management of runoff at the point where it gathers or is discharged to a receiving water body.

Note: The source-pathway-receptor can be applied at each level of a development (i.e., individual plot, site or part site, entire developments) and across existing and new developments as part of a community level intervention.

#### Statutory Duties

4. Where the Local Authority, as part of its flood prevention duties, requests long-term storage (see 2.7.1 of this Specification) to deal with temporary flood storage of storm events, this shall not be vested by Scottish Water.
5. For small developments, particular attention shall be given to prevention and source controls, as site or regional controls such as detention ponds may require a sizeable land-take. The reduction of runoff and the treatment of runoff at source will provide the required treatment levels as contained in Water Environment (Controlled Activities) (Scotland) Regulations 2011. (Note that source controls within private curtilage or serving road water only are not public SUDS and will not vest in Scottish Water). During the construction of any development, good site practice shall be followed in order to prevent runoff damage and pollution of any SUD system.
6. The developer shall be wholly responsible for the design and construction of sewerage infrastructure, including SUD systems, to serve the proposed development. The developer and/or his designer shall certify that their design complies with this Specification and accept liability for compliance through their professional indemnity insurance. These responsibilities/liabilities shall not be discharged to Scottish Water following a satisfactory audit of their design.

7. The developer shall take into account requirements for drainage when determining the overall layout of the development, as the natural features of the site will often dictate some aspects of the drainage system design and SUD system treatment train.

8. When undertaking the design using the specification provided in Part 2, the developer shall take cognisance of the following issues:

- a) the introduction of surface water into combined or foul sewers will not be permitted in all but very exceptional circumstances;
- b) the use of foul sewage pumping stations shall be avoided unless it can be demonstrated that is impracticable to do so;
- c) pumped surface water systems shall remain private;
- d) pumping stations which are an integral part of the sewerage system design shall be shown on the notice plan for the laying of the sewer;
- e) where a pumping station, pond or basin which has not been included in a notice plan is provided, the developer shall convey the land upon which it is located at no additional cost to Scottish Water. The developer shall also ensure that Scottish Water receives, to its satisfaction, the rights of access and that both the electricity supply and telecommunication connection are provided by Scottish Water-approved suppliers and are transferred to Scottish Water at the time of vesting;
- f) the developer shall take account of the timescale required to finalise land acquisition and gain SEPA or other relevant authority approval or consent for any pumping station overflow discharge, if required;
- g) for control of pollution, oil/petrol interceptors and other pre-treatment devices upstream of SUDS may be required;
- h) the developer shall undertake all licence discussions with SEPA through Scottish Water and any licences issued by SEPA shall be transferred to Scottish Water at the time of vesting.

9. Scottish Water has no statutory duty to, and shall not, accept groundwater or land drainage connections, and so the developer shall make separate disposal arrangements.

10. Scottish Water's policy is to support sustainable development: this protects the environment from pollution (from combined sewer overflows) and increases resilience to the risk of sewer flooding due to pressures of climate change and urban creep.

11. The strategy to deliver this policy is through the use of separate surface water (SUDS) and foul water sewers, together with the disconnection of legacy surface water connections to its combined sewers.

12. This design and construction standard relates to SUDS which Scottish Water will finance (up to reasonable cost thresholds) and vest. These are likely to form a discrete element of the overall land drainage arrangements, which shall be discussed and agreed with the Local Authority in line with Planning Advice Note 61 (PAN 61) outlining the site drainage strategy. This site drainage strategy shall include:

- An indication of the type of surface water management measures to be used;
- Evidence of sub-soil porosity and suitability for the use of infiltration SUDS (Note: Scottish Water does not currently vest infiltration SUDS);
- Pre- and post-development runoff calculations to determine the scale of SUDS required;
- Assessment of flood risk (where development/sewers are within 1-in-200 year flood risk areas);
- Proposals for integrated drainage systems into the landscape or required public open space;
- Demonstration of good ecological practice including habitat enhancement and erosion control measures;

- Estimated land-take for different drainage options, based on the requirements for drainage structures (property curtilage, roofs, roads and other impermeable areas) to integrate with surface water systems and/or watercourses within or adjacent to the development.

13. The developer shall separate surface water runoff and, where soil permeability permits, discharge the surface water from buildings and hard standings via local soakaways. Where the developer can demonstrate clearly that this is not practicable (due to soil permeability and location of existing adjacent structures), the developer shall provide separate surface water drains to the curtilage boundary of the property to allow transfer and connection to a surface water drainage system. This arrangement may include a shared roads drainage “vestable” surface water sewerage arrangement, as specified in more detail in Sub-Section 2.1 of this Specification.

14. Land drainage measures to convey flows to alternative receptors such as gullies, strip drains, filter drains, swales, filter strips, filter trenches, culverts or existing natural watercourses or manmade wetlands surface water disposal arrangements are not appropriate for vesting with Scottish Water, see Planning Advice Note 61 (PAN 61). Arrangements for the ongoing management of these and watercourses including surface water, land drainage structures and other water features shall require to be agreed between the developer and the riparian land owners.

15. In accordance with Section 7 (3) of the Sewerage (Scotland) Act 1968, subject to entering into a formal Vesting Agreement, Scottish Water shall grant permission and technical approval conditions it deems appropriate to the drainage arrangements as part of its development connections approval process. These will include, but are not limited to: points of connection, agreements with Local Authorities (Roads Authorities) regarding shared drainage maintenance arrangements for the piped surface water sewerage systems and, where agreed, associated detention ponds/ basins and underground storage.

16. Surface water systems which do not include statutory surface water (drainage from property curtilages), as defined under the Sewerage (Scotland) Act 1968 will not be vested.

17. The developer shall make arrangements for aboveground protection strips and landscaping maintenance, and agree with third parties any flooding measures related to the discharges from the surface water systems.

## **2.2 DRAINAGE SYSTEMS SUITABLE FOR VESTING**

1. Scottish Water will vest, where it has entered into a Vesting Agreement, the foul sewerage and surface drainage systems. In most situations, the surface water systems will include SUD systems (detention ponds, detention basins, swales and piped filter trenches and also underground detention storage tanks). The full range of SUDS techniques shall be considered upstream of the vested SUD system, where their use is appropriate to minimise surface water runoff.

2. Swales and piped filter trenches used as SUD components shall only be vested by Scottish Water where used as ‘end of pipe’ systems.

3. If a developer proposes a variation from this Specification, then they shall apply to Scottish Water for a waiver. This application shall include all necessary data and information to prove that the proposed design is a better solution for that site than would be provided by this Specification. If Scottish Water accepts and agrees with the evidence they will then provide written confirmation of acceptance of the waiver. All waivers to Sewers for Scotland and associated Scottish Water specifications shall be recorded in the Vesting Agreement and associated approved drawings.

4. Attenuation storage structures, including their embankments and access roads, shall normally be vested in Scottish Water.

Note: This is to ensure continuity of ownership and maintenance of the vested surface water system from underground pipework through to the outlet attenuation control arrangement. The 1-in-30 year

storm return “top water level” is the minimum extent of land title ownership acceptable, with associated maintenance access agreement allowing access to outlet control structures for a 1-in-200 year storm and to de-silt the pond or basin.

5. All SUD systems to be vested shall be located in passive public open space. SUD systems located within property boundaries or SUD systems draining roads water in close proximity to roads (as defined by the Roads Authority) shall not vest in Scottish Water.

6. All SUD systems shall be de-silted by the developer during the final six months of the Guarantee Period prior to vesting. The excavated material and vegetation shall be appropriately disposed of and vegetation affected by the process made good. This includes the complete removal of all inappropriate, and in particular, invasive non-native species (INNS) of vegetation in compliance with Waste Management legislation, the developer will be responsible for ensuring planting becomes established over the 2-year Guarantee Period following vesting and make arrangements for its maintenance thereafter.

7. Where pollution from rainfall-runoff for a development site is likely to be significantly greater than for standard residential developments as determined by SEPA (WAT-RM-08) (including vehicle parking, commercial vehicle loading areas, commercial materials handling/storage areas) or where the receiving water is "sensitive", and where effective treatment cannot be implemented within private properties or using SUD systems normally vested in Scottish Water, specific consideration shall be given to the use of multiple treatment pond SUD systems to ensure pollution levels are compatible with those from standard residential developments. Such multiple detention/treatment pond arrangements shall be subject to detailed discussions with Scottish Water and SEPA. Surface water discharge from industrial development sites will require a SEPA licence agreement which shall include trade premises drainage arrangement discussions and restrictions as part of the technical approvals.

8. Sewers proposed for vesting by Scottish Water shall become public sewers on issue of the Vesting Certificate. Scottish Water will operate and maintain the sewers from the date of the issue of the vesting or sectional Vesting Certificate.

9. Any private drainage system connecting to the vested drainage system and the subsequent discharge to a watercourse shall have the ownership and maintenance responsibilities clearly established by the developer and discussed with Scottish Water prior to Scottish Water accepting its connection.

### **2.3 GENERAL DESIGN REQUIREMENTS**

1. The developer is responsible for all aspects of the design of both the foul sewer system and surface water drainage system, including SUD systems. The design shall incorporate a design risk assessment to ensure risks to both the local community and operators of the drainage system are minimised. The Health and Safety Executive (HSE) identifies SUD systems as workplaces and, therefore, the developer shall abide by obligations under the Health and Safety at Work etc., Act 1974 and any other relevant safety legislation. The developer and/or his designer shall certify that their design complies with this specification and accept liability for compliance through their professional indemnity insurance. These responsibilities/liabilities shall not be discharged to Scottish Water after the design passes a satisfactory audit.

2. The design shall be carried out generally in accordance with this design and construction standard and related best practice principles in current UK drainage guidance. The discharge of surface water from a development site shall comply with design criteria in the agreed drainage assessment document (Drainage Assessment: A Guide for Scotland) and in this Specification in order to:

- a) protect the watercourse from pollution;
- b) not increase flood risk from the watercourse downstream or upstream of the site;
- c) protect the morphology of the watercourse;



- d) provide ecological and aesthetic benefits; and
- e) provide the required level of service against flooding for the development.

3. As required by Section 7 (3) of the Sewerage (Scotland) Act 1968, all development drainage shall be separated up to the point of connection to the public sewerage system.

4. Calculations and construction details for private surface water drainage and pipe drainage, which drain to any proposed vested system, shall be submitted to Scottish Water as part of the audit for the design of the proposed system to be vested. Developers shall discuss and agree the Local Authority and Scottish Water the most appropriate and integrated surface water drainage arrangements not only specific to their development site, but within the general vicinity of their site to ensure that a fully integrated surface water management strategy is in place.

5. The developer shall provide separate foul and surface water drainage systems for both greenfield and brownfield developments.

6. The complete surface water drainage system for a development comprises watercourses, private drainage,(including drains, culverts, private SUD systems etc.), vested drainage (surface water sewers, ponds, basins, swales, filter trenches and any associated underground storage) and possibly drainage owned by the Local Authority. The extent of responsibilities and ownership of Scottish Water-vested drainage shall be clearly defined in the Vesting Agreement and associated drawings.

## **2.4 DRAWINGS, CALCULATIONS AND MANHOLE RECORDS**

1. Drawings and calculations shall be supplied for the whole sewerage system design, including elements not to be vested but which contribute to the vested system: in particular property drains from roofs, surface drainage, roads drainage and foul-only property drains. Separate drawings of private systems (including land drainage systems and culverts) shall be supplied for record purposes only.

2. All drawings and calculations submitted shall be in metric units.

3. Layout plans shall be prepared in accordance with Appendix III. Illustrations demonstrating the type of information to be included on the SUD system drawings are presented in Figures 1 to 7. These Figures are simplified idealised layouts and are not intended to be copied. The drawings submitted by the developer shall show the precise layout as dictated by local topography and all the necessary detailed information required in this Specification.

4. Location and layout plans, longitudinal sections and details shall show the drainage system and development in full. Plan scales shall be those in common use, i.e., 1:200, 1:500, 1:1250 or 1:2500, as appropriate. The plans submitted shall also show the following:

- a) layout of roads and properties including plot numbers and boundaries;
- b) layout of sewers, outfalls, underground storage tanks, property and gully connections including the positions of disconnecting chambers, detention ponds, detention basins, any other SUD system features including source controls, details of all associated features and the external property drainage details;
- c) vested structures and areal boundaries of all drainage systems which are not buried underground shall be highlighted;
- d) contours or existing ground levels and property floor levels all related to Ordnance Datum;
- e) longitudinal sections showing proposed levels, existing ground levels and invert levels, all related to Ordnance Datum, together with manholes, chainages, gradients, pipe sizes, pipe materials, detention ponds, detention basins and areas where protection of pipework is required. All manholes shall be given numbers for identification purposes;
- f) all structures or trees which are, or shall be, greater than 10 m high within 10 m of the proposed drainage system infrastructure;

- g) layout taking into account possible future developments;
- h) location of the OS Benchmark and its value;
- i) location and extent of any infiltration system.

Note: Longitudinal sections shall generally be to an exaggerated scale, with the horizontal scale the same as the plan (but no less than 1:500) and the vertical scale 1:100.

5. Record drawings i.e. "as-builts" shall contain the following as-built information:

- a) structure and manhole locations, to 300 mm accuracy in the horizontal plane, with dimensions related to fixed Ordnance Survey features or Ordnance Survey coordinates to 1 m accuracy (12-digit accuracy, e.g., 123456, 123456);
- b) cover levels and invert levels related to Ordnance Datum and within  $\pm 10$  mm tolerance;
- c) chainages and gradients; and
- d) all pumping stations and SUD system features.

# SECTION 2B – SURFACE WATER DRAINAGE DESIGN

## 2.5 SEWER DESIGN DETAILS

1. For details of the layout of pipework for surface water sewers, design of manholes, depths of sewers and minimum sewer diameters, reference shall be made to Section 2C below.

## 2.6 HYDRAULIC MODELLING DESIGN

1. The surface water system shall be designed and constructed so that flooding does not occur in any part of the site in a 1-in-30 year return period design storm flood frequency, with a 1-in-200 year overall minimum flood resilience assessment check, as may be required, by the Local Authority and SEPA in particular for developments in flood vulnerable areas.

Note: For all developments which utilise SUD systems, the use of appropriate analytical tools are likely to be needed to demonstrate the required level of flood protection performance. For developments having less than ten houses, pipe full design using 40 mm/hour intensity rainfall can be assumed to provide an adequate level of service against flooding.

2. Representation of SUD systems in simulation software shall be explicit, where possible. A copy of the model and results shall be made available to Scottish Water upon request. Representation of the hard surfaces draining to the network shall be accurately allocated to the drainage system and all manholes included in the model.

3. Surface water drainage shall be designed for runoff from roofs and, subject to the agreement of Scottish Water, roads (including verges) and other hard-standing areas. For these areas, an impermeability (runoff) coefficient of 100% shall be assumed.

4. An additional increase in the paved surface area of 10% shall be assumed for all areas to allow for future urban expansion (extensions and additional paved areas) unless this would produce a figure greater than 100% of the total site area.

5. Design event rainfall shall be based on the use of the most recent version of the 'Flood Estimation Handbook' specific to the location of the development. An allowance for climate change of an additional 30% (by factoring the rainfall intensity hyetograph values) shall be applied unless otherwise agreed.

6. Surface water drainage systems shall not be designed to take runoff from other areas (see Clause 1.2.2), groundwater or land drainage. Separate arrangements for this runoff shall be agreed with the Local Authority as part of its flood prevention duties and confirmed to Scottish Water.

7. During severe wet weather, the capacity of the surface water drainage systems may be inadequate, even though they have been designed in accordance with this Specification. Examples of different weather conditions which cause flooding include:

- a) high-intensity events which can result in gully inlets being bypassed;
- b) high-intensity events which can result in sewers being surcharged and surface water escaping where the ground level is below the hydraulic head;
- c) high-intensity events in areas adjacent to the development site (urban or rural) from which overland flooding can take place;
- d) long-duration rainfall which may result in the top water level in storage systems becoming full, resulting in overflow from the units;
- e) extended periods of wet weather which may result in high receiving watercourse water levels affecting the hydraulics of the drainage system.

8. Checks shall be made for the 1-in-200 year return period plus climate change and additional paved area allowances to ensure that properties on and off site are protected against flooding for all these scenarios. The design of the site layout or the drainage system shall be modified where the required flood protection is not achieved. This is particularly relevant on undulating and steeply-sloping catchments and adjacent to watercourses. Developers shall also demonstrate flow paths or floodplains and the potential effects of flooding resulting from these storm events. In particular, access into and through the site for emergency vehicles shall be ensured for these events.

9. Where the pre-existing risk of flooding of the site is high or where there is an existing problem of flooding from the receiving watercourse to locations downstream, the developer shall liaise with Scottish Water, SEPA and the Local Authority (as part of its flood prevention duties) to ensure that all necessary measures are included in the design to prevent flooding of the development. The developer shall also demonstrate that the measures incorporated in the design are effective, both in protecting the site and minimising any impact downstream.

10. Where discharges are to be to existing drainage systems vested in Scottish Water, agreement with Scottish Water as to the acceptable discharge criteria shall be made. This may involve the modelling of the hydraulic performance of the receiving sewerage system.

## **2.7 DESIGN PHILOSOPHY**

1. The philosophy of SUD systems is to provide a drainage system that minimises the impact of diffuse pollution in urban runoff, reduces runoff and maximises the environmental and social benefits.

2. The runoff from the developed site shall, in principle, mimic the quality and quantity of the runoff from the site in its “greenfield” state, in so far as it is reasonable and practicable. It shall be noted that the Local Authority can apply stricter criteria.

3. The type of SUD ponds, basins, swales or piped filter trench, and outlet control systems, which are normally acceptable solutions for vesting are illustrated in Figures 1 to 15: These provide generic best practice guidance. Developers shall design the drainage system holistically for the site using appropriate systems and control structures in order to maximise operational advantages, surface water treatment and other aesthetic and environmental benefits within the framework of the requirements of this document.

Note: Whilst not considered appropriate for vesting by Scottish Water soakaways, infiltration type filter drains, infiltration swales; blue and green roofs; rainwater harvesting systems; water butts; and permeable hard-standings may offer best-value solutions to the management of surface water. The developer is expected to undertake a holistic view of surface water management and its integration into a sustainably-built environment through discussion and agreement with Local Authorities, SEPA and Scottish Water, as required under the Flood Risk Management (Scotland) Act 2009, in particular within identified flood vulnerable areas.

4. The developer shall design the system(s) for ease of access and efficient maintenance of the system(s), with a view to minimising future operational and maintenance costs, and provide a safe operating environment for the staff of Scottish Water and a safe environment for the local community. For information on maintenance of SUDS systems see The SUDS Manual (CIRIA Publication C753). The document is available from [www.ciria.org.uk](http://www.ciria.org.uk).

5. Where deemed necessary by the Local Authority to achieve a reduction in the rate of runoff and manage flows within the surface water catchment, attenuation of the discharge shall be provided. Attenuation storage which Scottish Water will vest is limited to the following:

- a) detention ponds;
- b) detention basins;
- c) swales
- d) piped filter trenches

- e) underground storage pipes and tanks.

6. Underground storage does not provide treatment and shall only be used in conjunction with SUD techniques for discharges direct to a watercourse in urbanised city/town centre development sites. Systems shall in all cases fully comply with the Water Environment (Controlled Activities) (Scotland) Regulations 2011.

Note: In exceptional cases on brownfield city/town centre sites (with no access to a separate natural or constructed surface water system) and where the developer can demonstrate it is technically impracticable to fully utilise approved SUDS arrangements, specific application for connection of statutory surface water to an existing combined sewer (or dual manhole system) using underground storage arrangements (with source controls to attenuate and limit off-site surface water flows) may be considered.

7. Any agreement to permit surface water connection to an existing combined system shall include requirements for off-set upstream or downstream combined sewer surface water disconnection and/or retrofit SUD system arrangement. This flood resilience requirement is additional to any measures taken to offset the foul flow to ensure the downstream network capacity has flood resilience against a design 1-in-30 year storm event. The agreement shall include land drainage/flood vulnerability resilience strategy discussions with SEPA and the Local Authority, as part of a Development Impact and Remediation Agreement. Approval to connect any surface water to existing combined or dual manhole sewer systems in all cases will require approval from Scottish Water.

8. Urban runoff increases the volume of stormwater runoff compared to greenfield runoff, especially for frequent rainfall events. To minimise the impact of this additional runoff, the use of infiltration systems and flood detention is encouraged, where practicable (although they shall not be vested). Where infiltration or surface water networks do not provide sufficient reduction of runoff, the use of longer-term storm return period storage (for up to and including 1-in-200 year events) to address this additional runoff volume and flood routing is recommended. Where longer-term storage (above a 1-in-30 year storm) is required, the associated flood basins and land shall not be vested by Scottish Water. For more information, see 2.7.1 of this Specification. Guidance on long-term storage may be found in 'The SUDS Manual'.

### **2.7.1 Attenuation Storage**

1. The Local Authority, as part of its flood prevention duties, may require protection for a watercourse to be provided by the attenuation storage from which the site runoff is discharged. This is likely to require attenuation of the site peak runoff rate and a reduction in the total volume of runoff. Where long-term storage or attenuation is required beyond the 1-in-30 year design requirement, the associated additional storage or attenuation arrangements shall not be vested by Scottish Water.

2. Local Authorities may wish to lessen the runoff to receiving watercourses. The limiting discharge rates from the site shall normally be assessed using the formula for peak discharge assessment of greenfield runoff in 'Report No. 124: Flood Estimation for Small Catchments' (1994). For areas smaller than 50 hectares, it shall be applied for 50 hectares and linearly interpolated. Values shall be determined for the 1-year, 1-in-30 year and any more extreme events in accordance with criteria specified by the Local Authority.

3. Checks for extreme events shall be in accordance with planning documents such as 'Scottish Planning Policy (SPP)', 'Planning Advice Note PAN 61: Planning and Sustainable Urban Drainage Systems' and 'Planning Advice Note PAN 69: Planning and Building Standards Advice on Flooding', as well as Drainage Assessment: A Guide for Scotland. For additional information, the Local Authority shall be contacted. An example calculation for finding the greenfield runoff flow rates for the site is provided in Appendix VII.

4. The maximum 1-year water level in the pond shall not cause significant backing up (beyond pipe soffits) of flows in the incoming sewers. In addition, the 1-in-30 year water level shall not cause flooding from the drainage system in a 1-in-30 year storm event. The models shall demonstrate flood routing for a 1-in-200 year event, including any impact on the performance of the surface water sewers.

5. The attenuation storage volume shall be found using simulation modelling of the contributing development area taking into account the head-discharge relationship of the proposed pond discharge outlet. Appropriate allowance in the reduction in runoff shall be made for infiltration systems serving any impermeable areas.

Note: The model may be based on using either the fixed percentage runoff of 100% runoff from all impermeable surfaces, or the UK variable runoff model (see 'Drainage of Development Sites – a Guide' (2004)) for the runoff from the whole site.

## **2.7.2 Sewers**

1. The minimum velocity in sewers to be vested shall be 1 metre/second at pipe-full flow when draining hard surfaces with direct runoff, whether SUD systems serving other areas exist or not. The minimum velocity for pipes that only receive discharges from SUD systems that can reasonably be expected not to pass forward sediment (such as pervious pavements or ponds), without additional downstream direct connections from impermeable surfaces, shall be greater than 0.3 metres/second for a 1-year event.

2. The design of all stormwater drainage shall ensure that a minimum 1-in-30 year level of service (including allowances for climate change and additional paved areas) is provided (no flooding). Consideration shall be given to the possibility of private SUD systems being modified, removed by their owners or failing, and ensure that the drainage continues to provide a 30-year level of service against flooding.

3. The roughness value ( $k_s$ ) for surface water sewer design shall be 0.6 mm.

## **2.8 WATER QUALITY**

1. Water quality improvements are achieved more efficiently using the treatment train process (see 'The SUDS Manual').

2. Water quality improvement to the surface water runoff shall be given a high priority when designing the drainage system. SUD systems considered for vesting by Scottish Water for providing treatment of surface water runoff are detention ponds and basins, 'end of pipe' swales and piped filter trenches. Underground storage does not provide any effective treatment.

3. For surface water quality treatment, a minimum permanent pool volume of one treatment volume shall be provided for residential developments. Large commercial and industrial sites (and other non-residential situations) may require enhanced design criteria (up to four treatment volumes) with particular attention paid to the application of all aspects of the treatment train. Liaison with SEPA is required where industrial areas are being treated via detention ponds, swales or basin-specific agreement will be required with SEPA and Scottish Water in relation to treatment, volumetric discharge measurement, sampling facilities and licensing.

4. SUD systems serving high risk development that require simple licence from SEPA (i.e. >1000 houses/car park spaces, industrial estates, motorway/major road) shall be kept separate from SUDS systems serving low risk developments authorised by GBR 10.

Note: Where ponds are used, to maximise water quality and other benefits, it is preferred that the design uses ponds in series (two or three) together with a sedimentation forebay, particularly for sites where road runoff is not treated prior to entering the pond.

## **2.9 PONDS**

### **2.9.1 Detention Ponds – Configuration and Dimensions**

1. Ponds shall appear, in so far as is reasonably practicable, to be natural. They shall not be built in symmetrical shapes or have angular corners. Ponds may provide wider environmental benefits for bio-diversity.

2. All ponds shall include the following elements:

- a) maintenance access route approximately 3.5 m wide, suitable for a vehicle;
- b) an inlet structure with an overflow and bypass (Note: Upstream bypass is only required when specifically requested by Scottish Water);
- c) a sedimentation forebay;
- d) an open clear water pond area;
- e) shallow water aquatic bench around the pond to support both submerged and emergent aquatic plants, the latter acting as barrier planting;
- f) an outlet structure with an integral overflow (if not provided at the inlet) and drawdown facility;
- g) a separate spill overflow structure (with a planned flood route).

3. The dimensions of the pond shall be based on:

- a) a minimum length to width ratio of 3.5 to 1;
- b) including a zone with a minimum permanent pool deep-water depth of 1.2 m (to limit plant growth);
- c) a maximum permanent pool deep-water depth of 2.0 m (to limit stratification);
- d) a minimum permanent pool volume based on 15 mm of rainfall from impermeable (including paved and roofed) surfaces draining to the pond. (Note: This can be reduced when runoff from these surfaces has passed through other SUD systems components.) This reduction in volume shall never be greater than 75% and shall relate to the degree of effectiveness in sediment reduction and hydraulic control provided upstream;
- e) the volume of the sediment forebay shall comprise approximately 10% of the pond's permanent volume;
- f) the average width of the sedimentation forebay shall be 5 to 10 times the diameter of the inlet pipes (or equivalent diameter if more than one);
- g) the minimum length of the sedimentation forebay shall be 10 m or four times the width of the sedimentation forebay;
- h) the alignment of the inlet and outlet shall maximise flow detention times and minimise the risk of flows short circuiting;
- i) outlets shall be located as far from the inlet as reasonably practicable;
- j) the width of the aquatic bench shall be a minimum of 2 m and shall be continuous around the pond, except in front of the inlet(s);
- k) the depth of the aquatic bench shall range from the permanent pool water's edge up to a maximum depth of 450 mm;
- l) the maximum range of water level for attenuation of runoff shall not normally be greater than 2 m.

4. The sedimentation forebay shall be separated from the main pond area using gabions or another robust type of structure. These shall be built to within 150 mm below the permanent pool water level and extend horizontally for the full width between the main pond and the sedimentation forebay.

### **2.9.2 Detention Ponds – Sizes**

1. During the design stage, the use of two or three ponds in series rather than one large pond may be considered, however, a proliferation of small ponds distributed around the development shall be avoided.

2. Any pond volumes expected to exceed 5,000 m<sup>3</sup> and any embanked pond greater than 10,000 m<sup>3</sup> shall be referred to Scottish Water for special consideration.

3. The size of the sedimentation forebay is dictated by both the sedimentation process and maintenance requirements. Where maintenance is to be carried out from a maintenance access way, the maximum distance to any point in the sedimentation forebay shall be within reach of appropriate maintenance equipment (generally assumed to be a mechanical excavator with an excavator bucket adequate to remove any build-up of sedimentation material). Where vehicular entry is designed to the sediment forebay, access and manoeuvring constraints, as well as structural requirements, shall be considered.

### **2.9.3 Detention Ponds – Location**

1. All ponds shall be located at suitable topographic locations in passive public open space and with an access route around the pond. Furthermore, where possible, the pond shall be sited a distance away from the development and with a public road between the asset and the nearest buildings. The distance shall be determined as a result of an appropriate design risk assessment considering the type of buildings near the facility.

2. The design risk assessment shall include all relevant safety issues associated with a pond.

3. The maximum flood water level in any detention pond shall be at least 500 mm below the floor level of any adjacent premises.

4. The maximum 1-year return period event pond water level shall be higher than the appropriate return period event water level of the adjacent watercourse, as specified by the Local Authority. Appropriate hydraulic checks on the implications of high watercourse levels shall be made, where appropriate.

5. The permanent pool water level of a pond in permeable soils shall be designed to be at least 300 mm higher than the maximum groundwater level at the location determined by the site investigation report.

### **2.9.4 Detention Ponds – Inlet Structure**

1. The inlet structure shall constitute a man-entry chamber immediately upstream of the sedimentation forebay. All incoming flows shall connect to, or immediately upstream of, the inlet structure. The overflow structure for the pond may be provided in the inlet chamber.

2. Penstocks and a bypass sewer shall be provided to enable all flows from the inlet sewer to be diverted from entering the sedimentation forebay, primarily to assist with maintenance. These shall be able to be operated from outside of the inlet structure. The bypass sewer shall be sized to provide an equal flow capacity to the inlet sewer(s). Where a bypass sewer is thought unnecessary or impractical, this may be omitted subject to written agreement with Scottish Water.

3. The invert(s) of all the incoming sewers to the inlet structure shall preferably be at or above the maximum 1-year water level in the pond (making due allowance for climate change and allowance for increased paved areas).

4. The inlet into the sedimentation forebay shall normally be above the permanent pool water level and discharged onto a reverted apron which has energy dissipation characteristics. The apron shall extend to the base of the sedimentation forebay.

5. Where long-term storage which is not vested in Scottish Water is to be mobilised beyond the 1-in-30 year storm level or from the pond to other SUD features during severe events, flows can be diverted from either the inlet or outlet structure or through the side of the pond, whichever is more convenient.



### **2.9.5 Detention Ponds – Sedimentation Forebay**

1. The unit shall be designed to maximise sedimentation before passing into the main pond area.
2. The floor of the sedimentation forebay shall be designed 300 mm above the floor of the main pond to allow complete drain-down of the unit for maintenance.
3. The base of the sedimentation forebay shall be constructed using reinforced concrete to provide a hard base to allow effective excavation of the deposited sediment without damaging the liner.
4. Where access into the sedimentation forebay by maintenance vehicles is necessary, it shall be designed to allow safe access without causing any damage to the structure.
5. Pond forebays serving residential areas shall be sized to allow 25 years of sediment storage based on 0.3 m<sup>3</sup> per hectare per year, based on hectares of impermeable (including roofed and paved) area. The volume of the pond shall be increased over and above the hydraulic volume by the volume of sediment storage.
6. Pond forebays serving industrial and commercial areas shall be sized to allow 25 years of sediment storage based on 0.8 m<sup>3</sup> per hectare per year. The volume of the pond shall be increased over and above the hydraulic volume by the volume of sediment storage.

### **2.9.6 Detention Ponds – Outlet Structure**

1. The outlet structure (i.e. flow control manhole) shall be a man-entry chamber having minimal visual impact. It shall be designed to operate and discharge the design-limiting discharge rates in accordance with the Local Authority requirements as part of its flood prevention duties. Appropriate hydraulic checks on the implications of high receiving watercourse levels on the effective operation of the outflow control shall be made, where appropriate. Throttle controls shall be provided using high-grade galvanised or stainless steel fixed to the concrete structure, allowing opportunity for modification and refining the operation of the control system in the future. The minimum diameter of any limiting discharge control orifice shall be 75 mm unless otherwise agreed. Orifice or vortex control units or similar may be used to control outflow rates.
2. If discharging to a receiving water, subject to the Local Authority requirements, the outlet structure control(s) shall discharge at the design 1-year return period outflow rate when the pond is at the 1-year return period water level for the critical design storm event. Similarly, this applies to the control for the 30-year return period and any greater return period event as required by the Local Authority as part of its flood prevention duties. The full 1-in-30 year limiting flow rate can be discharged (within the constraints of head-discharge design) once the maximum water level of the 1-year return period event has been exceeded. Similarly, this applies to the control for the 30-year return period and any greater return period event as required by the Local Authority as part of its flood prevention duties. In all cases, flood routing shall be assessed for a 1-in-200 year event to ensure the integrity of the SUDS arrangements and their protection from erosion or associated risk.
3. In designing the site sewerage and layout, developers shall also demonstrate flow paths and the potential effects of flooding resulting from storm events exceeding the design criteria.

Note: Developers shall follow the guidance provided in the statutory guidance document 'Delivering Sustainable Flood Risk Management: Guidance Document (2011) and any surface water management plan that may have been developed by the relevant Local Authority.

4. If not provided at the inlet structure, the outlet structure shall have an overflow. An emergency overflow shall also be provided which shall not increase the risk of embankment failure.
5. Means shall be provided to drain the lowest point in the detention pond. A pipe shall be laid to the lowest point in the pond and a penstock at the same level shall be provided in the outlet manhole. The capacity of the drawdown unit shall be similar to the capacity of the inlet pipe(s) to the pond.

The penstock or other valving shall be able to be operated safely from outside of the outlet structure.

6. The top of the embankments shall be a minimum 300 mm above the top water level of the maximum design return period storm event.

7. The outlet structure shall be designed to operate and discharge the design discharge rates at the requisite storm return periods. Appropriate hydraulic checks on the implications of high watercourse levels shall be made, where appropriate.

### **2.9.7 Detention Ponds – Water Quality Design Criteria**

1. Ponds shall provide a minimum permanent pool volume equal to one times the treatment volume for paved surfaces not served by upstream SUD systems with sediment reduction processes. This volume is subject to potential contamination of contributing surface water and may require to be enhanced.

2. The water level in the permanent pool shall need to be maintained at all times where there is an aesthetic requirement. Ponds shall be made watertight to 300 mm above the outlet pipe level using an appropriately impermeable liner where ponds are constructed in permeable soils. The membrane liner shall be at least 0.75 mm thick, under laid by 50 mm of sand to prevent damage. The liner shall have a slope of 2% towards the drain down outlet. The liner material shall be a single layer of butyl compound or polythene. If polythene is used, it shall in addition be protected by a geotextile fabric. A design risk assessment shall be submitted to seek Scottish Water's approval where the designer determines a liner is not required.

3. Pond liners shall be finished at a height 150 mm below the outlet control unit to encourage infiltration and to minimise discharges to the receiving water for small events. However, they shall not be lower than the invert level if used on a site with a sensitive underlying groundwater zone or if used to treat runoff from a potential pollution location such as drainage from parking areas.

4. Drain down time for maintenance purposes shall be a minimum of 12 hours to allow for sedimentation to take place

### **2.9.8 Detention Ponds – Operation and Maintenance**

1. A permanent maintenance access route shall be constructed to the pond such that it is operational in all weather conditions and permits access for all relevant types of vehicles and equipment that may be required to operate and maintain the pond. It shall have a minimum width of 3.5 m and shall be located immediately above the maximum 30-year water level including allowances for climate change and increased paved areas allowance. It shall provide (as a minimum) access to the inlet, fore bay, outlet and control structures.

2. The design of the pond and surrounds shall also include the required space for the removal and processing of excavated material, in accordance with current best practice.

3. The outlets from ponds shall be designed to permit the easy clearing of blockages.

4. Maintenance of access tracks, fencing, litter picking, landscaping and planting, and grass cutting shall be managed as detailed in the Vesting Agreement.

5. Adjacent land shall not convey runoff on to the maintenance access route and shall be intercepted by appropriate land drainage.

6. The provision of tanker access must be allowed in the event of severe pollution so that emptying can be achieved. The provision shall allow for access by a tanker with sufficient capacity to completely empty the pond up to a maximum of 18,000 litres (4,000 gallons)

### 2.9.9 Detention Ponds – Safety

1. The design risk assessment shall cover all relevant safety issues for both operatives and local residents. Signs and safety equipment shall be provided at all ponds in accordance with the findings of the design risk assessment.

Note: The maximum side slope between the maintenance access path and the aquatic bench shall normally be 1:4 to allow easy egress from the pond, with a maximum slope of 1:12 on the defined maintenance access route into the pond. The maximum slope for access points shall be defined by the health and safety plan for the site.

2. All vertical drops greater than 1.2 m shall be protected.

Note: Wherever possible, vertical drops shall be avoided or graded to shallow slopes to minimise health and safety risks.

3. The aquatic bench shall be planted with appropriate species to achieve a high-density barrier when mature which effectively dissuades people from trying to get access to the open water. Dense or tall vegetation (bushes and trees) around the external perimeter of the ponds shall be discouraged in order to provide high levels of visibility of the whole pond area.

4. Barrier fencing shall be considered as part of the initial design risk assessment at all detention ponds. The design risk assessment shall address such issues as:

- Proximity of the SUD system to schools, nursery schools, old people's homes;
- Proximity of the SUD system to public access leisure routes i.e. pedestrian pathways;
- Known areas where there is a high degree of vandalism;
- Children's play areas;
- Extent of being overlooked by nearby properties.

5. The design risk assessment shall also take into consideration that a SUD system may not be a recreational area and is a workplace as defined in the Health and Safety at Work etc. Act 1974 and the adequacy of the risk assessment shall be demonstrated as part of the Local Authority planning application and the site's Drainage Health and Safety Plan provided under the Construction (Design and Management) Regulations.

6. Where fencing is provided, all access gates shall be (childproof) lockable. Where provided, the minimum height of the fence shall be 1.1 m and shall be constructed in such a manner that there are no step-ups to reduce the 1.1 m minimum height. The form of the fence shall not detract from the aesthetic value of the local environment and shall match the design risk assessment requirements.

7. All exposed pipe inlets or outlets which are larger than 350 mm shall have safety grilles. However, where grilles can be avoided by the use of appropriate design to restrict unauthorised access into the structures, this is preferred. Grille designs shall be suitable to minimise the risk of blockage, have safe access for clearing during extreme events and prevent unauthorised access, particularly by children and pets. A typical safety grille and outfall is illustrated in Figures 8 and 9 respectively.

8. Bar spacing shall not exceed 150 mm and shall not be less than 75 mm to limit trapping small debris.

9. Consideration shall be given to the potential failure of any embankment and the subsequent flood flows through, and downstream of, the site.

10. Signs denoting any infrequent and temporary flooding of the area, and warning against swimming, dangers from thin ice, etc., shall be provided in line with the site-specific design risk

assessment. In addition, reference shall be made to Scottish Water's SUDS Vesting Guidelines which provides further signage information on the environmental aspects of ponds.

### **2.9.10 Detention Ponds**

1. Suitable aesthetic considerations relating to protecting and enhancing landscape quality shall inform the design of the pond and its surrounds. Maintenance of access tracks, fencing, litter picking, landscaping and planting, and grass cutting shall be detailed in the Vesting Agreement. Scottish Water shall only provide a maintenance service in relation to de-silting the pond, underground pipework and detention structures and maintenance of SUD systems.

2. The use of the pond for any recreational activities shall not be permitted.

### **2.9.11 Detention Ponds – Ecology**

1. Suitable native planting and variation in the physical characteristics of the pond shall be provided to maximise the ecological value of the pond and surrounds. These measures shall include the use of appropriate species and take account of habitat plans in the local biodiversity plan for the area. Further guidance on appropriate planting can be obtained from the CIRIC SUDs manual<sup>0</sup> and Scottish Natural Heritage.

Note: Variability of the water's edge, both in terms of slope and vegetation is desirable to maximise ecological habitat.

2. The perimeter of the pond 1 m inside and outside the water's edge (water level during dry periods) shall have a gradient of less than 1:10. This shall provide a margin which is attractive to flora and fauna and provide a natural-looking disincentive for people to enter the pond. Other areas (above and below the pond) shall have gradients of less than 1:4.

## **2.10 DETENTION BASINS**

### **2.10.1 Detention Basins – Configuration and Dimensions**

1. Detention basins shall preferably not be built with symmetrical shapes and angular corners, particularly in areas where aesthetics are important.

2. Where possible, the detention basin shall have an open aspect for the flood area above the maximum 1-year water level to allow use as passive public open space.

3. All detention basins shall have the following elements:

- a) access with a minimum width of 3.5 m to access the basin suitable for maintenance vehicles;
- b) slopes no greater than 1:4 to allow regular litter removal and grass-cutting maintenance;
- c) an outlet structure with an integral overflow and drawdown facility;
- d) outlet structures located as far from the inlet as reasonably practicable;
- e) a separate emergency overflow structure (with a planned flood route);
- f) a low-flow channel through the basin to ensure that the base empties completely and dries out, connecting the inlet structure(s) to the outlet structure(s). Refer to Fig.5 for low-flow channel requirements.

4. The dimensions of the detention basin are to be:

- a) a maximum depth of 3 m;
- b) the base of the detention basin shall be specifically designed for the operation of maintenance vehicles if vehicular access into the structure is proposed;
- c) with falls towards the centre i.e. low flow channel across the base of the basin:

- d) the maximum depth of water level for attenuation of runoff shall not normally be greater than 1.3 m as shown on Figure 5.

### **2.10.2 Detention Basins – Sizes**

1. Any detention basin volumes expected to exceed 5,000 m<sup>3</sup> and any embanked detention basin greater than 10,000 m<sup>3</sup> shall be referred to Scottish Water for special consideration.

### **2.10.3 Detention Basins – Location**

1. A design risk assessment shall include all relevant safety issues associated with siting a basin.
2. Detention basins shall be located at suitable topographic locations, in passive public open spaces.
3. The maximum water level in any detention basin shall be at least 500 mm below the floor level of any adjacent premises.
4. Consideration shall be given to the potential failure of any embankment and the subsequent flood flows through, and downstream of, the site.
5. The maximum 1-year return period event basin water level shall be higher than the appropriate return period event water level of the adjacent watercourse, as specified by the Local Authority as part of its flood prevention duties. Appropriate hydraulic checks on the implications of high watercourse levels shall be made, where appropriate.

### **2.10.4 Detention Basins – Inlets**

1. The detention basin inlets shall be slightly higher than the base of the detention basin with suitable energy dissipation and erosion protection provision.
2. To restrict human access, all exposed pipe inlets or outlets larger than 350 mm shall be appropriately designed with safety grilles. Grilles shall be designed to minimise the risk of blockage and allow safe access for cleaning during extreme events. A typical safety grille and outfall and is illustrated in Figures 8 and 9 respectively.
3. Detention basins shall be designed with a slight depression in the area of the inlet structures to encourage the water quality benefits of bio retention processes.
4. All penstocks or similar control valves shall be able to be operated safely from outside of the inlet structure.

### **2.10.5 Detention Basins – Outlet Structure**

1. The outlet structure i.e. flow control manhole shall normally be a man-entry chamber having minimal visual impact. It shall be designed to operate and discharge the design-limiting discharge rates in accordance with the Local Authority requirements as part of its flood prevention duties. Appropriate hydraulic checks on the implications of high receiving watercourse levels on the effective operation of the outflow control shall be made, where appropriate. Throttle controls shall be provided using high-grade galvanised or stainless steel fixed to the concrete structure, allowing opportunity for modification and refining the operation of the control system in the future. The minimum diameter of any limiting discharge control orifice shall be 75 mm unless otherwise agreed. Orifice or vortex control units or similar may be used to control outflow rates. Examples of outlet structures are illustrated in Figures 4 and 7.
2. If discharging to a receiving water, subject to the Local Authority requirements, the outlet structure control(s) shall discharge at the design 1-year return period outflow rate when the basin is at the 1-year return period water level for the critical design storm event. Similarly, this applies to the

control for the 1-in-30 year return period and any greater return period event, as required by the Local Authority as part of its flood prevention duties. The full 1-in-30 year limiting flow rate can be discharged (within the constraints of head-discharge design) once the maximum water level of the 1-year return period event has been exceeded. Similarly, when the 1-in-30 year water level has been exceeded, any higher limiting discharge flow rate can be mobilised. When the maximum design water level has been exceeded and the basin's overflow comes into operation, routing of the flood flows shall be considered.

3. The outlet structure shall have an overflow provided. In addition, an emergency overflow shall be provided as a separate structure but this shall not be constructed through an embankment. The flood flow from the emergency overflow shall be routed to avoid flooding of downstream properties.

4. Embankments shall be a minimum 300 mm above the maximum return period storm event.

5. The outlet structure shall be designed to operate and discharge the design discharge rates at the requisite storm return periods. Appropriate hydraulic checks on the implications of high watercourse levels shall be made, where appropriate.

6. All penstock or similar control valves shall be able to be operated safely from outside of the outlet structure.

#### **2.10.6 Detention Basins – Water Quality Design Criteria**

1. There are limited water quality design criteria for detention basins. A slight depression forming a bioretention area shall be designed around inlets. This bioretention area shall be protected from high energy flows, which will aid water quality treatment. The bioretention area shall not be in deep water, with a 150 mm maximum water depth.

2. Drain down time shall be a minimum of 12 hours to allow for sedimentation to take place.

3. Where detention basin liners are to be used in areas of high groundwater, the basin shall have a base level 500 mm above the maximum groundwater level.

4. On brownfield sites, the developer shall make a declaration to Scottish Water that contamination risk to surface water drainage into the SUD system has fully addressed any risk of groundwater pollution.

#### **2.10.7 Detention Basins – Operation and Maintenance**

1. Permanent maintenance access shall be constructed to the detention basin such that it is operational in all weather conditions and permits access for all types of vehicles and equipment that may be required.

2. Maintenance of access tracks, fencing, litter picking, landscaping and planting, and grass cutting shall be managed in the Vesting Agreement. Scottish Water shall only provide a maintenance service in relation to de-silting the pond, underground pipework and detention structures and maintenance of SUD systems.

3. The provision of tanker access must be allowed in the event of severe pollution so that emptying can be achieved. The provision shall allow for access by a tanker with sufficient capacity to completely empty the basin up to a maximum of 18,000 litres (4,000 gallons)

#### **2.10.8 Detention Basins – Safety**

1. The design risk assessment shall cover all relevant safety issues for both operatives and local residents. Signs and suitable safety equipment shall be provided in accordance with the design risk assessment. Signs denoting any infrequent and temporary flooding of the area shall be provided.

2. Dense vegetation around the external perimeter of the detention basin is discouraged to allow high levels of visibility of the area.

### **2.10.9 Detention Basins – Amenity**

1. Consideration shall be given to the suitable aesthetic design of the detention basin and its surrounds.

2. The dual use of the detention basin as passive public open space for recreation activities shall be considered where the area is subject to flooding from events less frequent than the 1-year return period and where it can be clearly distinguished from the area providing flood storage for frequent events. Where this dual use is proposed, consideration to the installation of educational and warning signage and safety equipment i.e. explaining purpose/ operation of the basin shall be considered to ensure safe usage and as detailed in a safety risk assessment,

### **2.10.10 Detention Basins – Ecology**

1. Suitable native planting shall be selected to maximise the ecological value of the detention basin and surrounds.

## **2.11 SWALES**

### **2.11.1 Swale configuration and dimensions**

Swales shall be implemented only as 'end of pipe' SUDS where intended for vesting by Scottish Water. Furthermore, this specification requires that a risk assessment is undertaken to demonstrate that infiltration from a swale is permissible with regards to groundwater flooding, ground and groundwater contamination, and geotechnical stability. Where infiltration is not permissible the swale shall be lined. Furthermore, no swale shall not be used to collect sheeting flow from the surrounding land or highways. Swales, as specified here, shall be used where required to provide a level of treatment in line with SEPA guidelines.

These 'end of pipe' swales are the only type of swale that Scottish Water shall consider vesting. Specifically, roadside swales shall not be considered for vesting where they receive runoff from the highway or verge. These arrangements however may form part of the highway drainage adopted by the local authorities, which may then connect to a vested SUDS.

The swale should be designed to convey or store the 1 in 30-year event when full. It shall provide, for all inflows, an average residence time of 9 minutes for the 1 in 1 year flow, to permit sufficient water quality treatment when the flow depth is less than 100mm, and have a corresponding flow velocity less than 0.3 m/s.

The construction of swales will need to be managed to ensure there is no sediment accumulation during the wider site works. Being shallow depressions, care should be made on site to ensure no accidental entry into the swales is made by plant or machinery such could result in damage to the swale. Any accidental damage to the swales during construction shall be fully rectified.

Swales shall appear, in so far as is reasonably practicable, to be natural. They shall be built to appear as natural depressions in the general ground surface that can provide wider environmental benefits for bio-diversity.

All swales shall include the following elements:

- a) maintenance access, approximately 3.5 m wide, to the inlet(s) and outlet suitable for a vehicle and trailer;
- b) each inlet structure shall include a sediment forebay, where appropriate a safety grille, and point source erosion control.

- c) an outlet structure with an integral overflow and shut off facility. The storage capacity of the swale can only be considered as part of the design where the outlet from or intermediate control from the swales is regulated.
- d) a separate spill overflow structure (with a planned flood route).
- e) an impermeable liner to prevent infiltration where a risk assessment requires it.

The dimensions of the swale shall be based on CIRIA 753:

- a) a maximum depth of the intended wetted channel (depth to invert) of 750mm for 80% of the swale length to account for piped inlet and outlets. Deeper swales shall be vested where dictated by topography and deemed acceptable by the health and safety risk assessment.
- b) a maximum water depth of 600mm for design events, including any storage component.
- c) a freeboard of 150mm shall be included to the design.
- d) a treatment flow depth of 100mm, being the height of the grass in the base, at which depth the flow shall be limited to 0.3m/s.
- e) a steepest side slope of 1 in 4 and preferably shallower.
- f) a minimum flat base width of 500mm or twice the diameter of the inlet pipes – whichever is the greater.
- g) a maximum flat base width of 2000mm.
- h) a maximum longitudinal gradient of steeper than 1 in 33 shall be permitted where they include check dams and other such approved flow detention devices. A slope shallower than 1 in 33 shall be required where no check dams are included. No swale shall be designed at a slope steeper than 1 in 10.
- i) shallow swales shall be designed to reduce the risk of erosion during flows. No swale shall be designed with a longitudinal gradient of less than 1 in 100 unless where permanent pools are featured. The minimum permissible bed gradient for a swale shall be 1 in 200. A length of swale required to achieve the minimum average residence time of 9 minutes for the 1 in 1 year flow

### 2.11.2 Swale Location

1. All swales shall be located at suitable topographic locations in passive public open space and with a vehicular access route along the full length of the swale. Furthermore, the swale shall be located at least 3m from the nearest private land boundary and the nearest buildings.

The maximum flood water level in any swale shall be at least 500 mm below the floor level of any adjacent premises.

2. Swales shall be linear in appearance with organic gentle curves. The bend radius shall be more than twice the top width of the swale.
3. Any external sheeting flows that might discharge into the swale must be intercepted and prevented from entering the swale. The design should consider the requirement for additional interception features to convey these flows: without such precautions runoff from garden areas, for example, could overload the swale that was designed only for the roofs and paved areas.
4. The design risk assessment shall include all relevant safety issues associated with a swale.
5. Vandalism, misuse and the longevity of the swale features shall be taken into account during the design, associated both with its day to day performance, and the required maintenance activities.



6. In designing and locating the swale, developers shall demonstrate flow paths and the potential effects of surface flooding resulting from storm events exceeding the design criteria. Developers shall follow the guidance provided in the statutory guidance document 'Delivering Sustainable Flood Risk Management: Guidance Document (2011) and any surface water management plan that may have been developed by the relevant Local Authority.

The maximum 1-year return period event water level in the swale shall be higher than the appropriate return period event water level of the receiving watercourse, sewer or SUDS, as specified by the relevant Authority. Hydraulic checks on the implications of high watercourse levels on the swale shall be made, where appropriate.

### **2.11.3 Swale inlet structures**

1. The inlet structure to a swale shall include a man-entry chamber and headwall. All incoming flows shall connect to an inlet structure.

The invert(s) of all the incoming sewers to the headwall chamber shall be at or above the maximum 1-year water level in the swale (making due allowance for climate change and allowance for increased paved areas through urban creep).

The inlet into the swale shall be no more than 100mm above the swale invert and discharged onto a concrete or revetment apron to minimise erosion. Energy dissipation shall be employed where inflows are determined by the design to be greater than 1m/s, this being the permissible velocity for grass. The apron shall include a sediment forebay.

The inlet structure, or structures, shall include for a sediment forebay or other sediment control device, and, where the incoming pipe is greater than 350mm diameter, shall incorporate a hinged safety grille (see Figure 8).

The sediment forebay, or catchpit, shall be designed to maximise sedimentation before passing into the swale.

The base of the sedimentation forebay shall be constructed using reinforced concrete to provide a hard base to allow effective excavation of the deposited sediment without damaging the liner. Where access into the sedimentation forebay by maintenance vehicles is necessary, it shall be designed to allow safe access without causing any damage to the structure.

Sediment forebays serving residential areas shall be sized to allow 1 year's worth of sediment storage based on 0.3m<sup>3</sup> per hectare, based on hectares of impermeable (including roofed and paved) area. Those swales serving industrial and commercial areas shall have their forebays sized to allow 1 year's worth of sediment storage based on 0.8m<sup>3</sup> per hectare.

The swale inlet structure shall be furnished with the ability to block the discharge of water in the event of pollution or similar incident – thereby preventing the spread of contamination downstream. This shall be by means of a tamper proof shut-off valve operated from surface level, or similar devices.

The inlet shall be designed to blend in with the surrounding landscape where possible. Mitred pipework with concrete collars, subject to the appropriate finishing, shall be permitted where depths and sizing permits. All incoming pipework greater than 600mm in diameter shall be afforded a full headwall.

Where long-term storage, which is not vested in Scottish Water, is to be provided beyond the 1-in-30 year storm level or from the swale to other SUDS features during severe events, flows can be diverted from either the inlet or outlet structure, though or over the side of the swale, whichever is more convenient. The design of this lateral connection should account for scour and erosion protection in the swale, and the design water levels at the connection point. No lateral structures for long term storage shall be vested by Scottish Water.

#### 2.11.4 Swale and water quality design criteria

1. In a swale, the grass slows down and filters surface water flows. Sediment is deposited, while oily residues and organic matter are retained to be broken down in the top layer soil and vegetation. No infiltration through the sides or base of the swale is permitted for those SUDS solutions put forward for vesting by Scottish Water unless accompanied by a risk assessment to consider groundwater flooding and/or contamination: where infiltration is not permissible, an impermeable liner shall form part of the design.
2. All swales shall have the capacity to convey, or store, the 1 in 30 year event for the discharge it receives, and the ability to remain operational with exceedance events up to the 1 in 200 year flood safely.
3. The swale shall be capable of discharging the design event to half empty within 24 hours: this is to ensure functionality for subsequent storms and protect saturation damage to the vegetation. Infiltration shall not be permitted for this SUDS solution or calculation of emptying time.

Swales shall provide for a normal treatment depth (or permanent pool volume) of 100mm with a corresponding flow velocity of 0.3m/s.

4. Swales shall be designed to afford no less than 9 minutes average residence time during flows generating the treatment depth (1 in 1 year flow), this being half the total travel time along the full length of the feature. Intermediate inlets to the swale shall, similarly, be afforded an average residence time of at least 9 minutes.

The maximum flow velocity during the 1 in 1 year design event must be less than 0.3m/s, and under no circumstances should the exceedance velocity exceed 1 m/s.

A Manning's roughness value of 0.350 should be used for treatment flows up to 150mm depth, reducing to 0.100 for flow at the design depth of 600mm (full capacity).

The top edges of the swale shall be rounded to allow safe and suitable mowing

Where the risk assessment requires, swales shall be made watertight to 150 mm below surrounding ground level using an appropriate impermeable liner, regardless of soils and underlying geology. A liner shall always be required where used on a site with a sensitive underlying groundwater zone, or if used to treat runoff from a potential pollution location such as drainage from parking areas.

Infiltration shall only be permitted where a suitable risk assessment is submitted.

5. Where required, the liner material shall be a single layer of butyl compound or polythene as a robust welded flexible membrane suitable for waterproofing to structures and water containment. The membrane liner shall be at least 0.75mm thick, having a minimum tensile strength of 18N/mm<sup>2</sup> and puncture resistance of a minimum of 150N. A permeability coefficient of  $1.8 \times 10^{-12}$  m/s is suggested.

Any liner shall have minimum laps of 150mm and be jointed using twin seam fusion welding in accordance with manufacturer's recommendations. Extrusion welding shall not be permitted except where approved by Scottish Water and twin seam welding is inappropriate.

Any liner shall be underlain and overlain by a minimum 50mm of sand to prevent damage. The sand shall comply with Part 4 (Engineering specification) of Sewers for Scotland v4.0.

If a polythene liner is used, it shall in addition be protected by an underlying non-woven needle punched geomembrane with a minimum thickness of 3.5mm and minimum static puncture strength of 2.5kN in accordance with BS EN ISO 12236, and tensile strength of 15kN/m under BS EN ISO 10319. A minimum overlap for the protection membrane shall be 300mm.

Alternatively a puddle clay liner may be used to separate the swale from the underlying ground, being a naturally occurring homogeneous plastic material. It shall be free from deleterious matter such as sand, stones and organic material. The use of lime-stabilised clays shall not be allowed. The puddle clay material shall be:

- a) Laid in 150mm consolidated layers with a minimum thickness of 300mm
- b) More than 65% of the natural material shall be finer than 0.06mm and more than 40% shall be finer than 0.002mm
- c) The natural material shall be defined as firm clay in accordance with BS5930:1981 Table 8 (Cu 40-75 kPa).
- d) The natural material shall be defined as clay of intermediate to extremely high plasticity in accordance with BS5930:1981, figure 31 and the liquid limit shall not be less than 35%.
- e) The coefficient of permeability (k) of the remoulded material shall not be greater than  $10^{-9}$  m/s.
- f) The remoulded material shall be defined as Non-dispersive (ND1) in accordance with BS1377:Part 5:1990, Table 2.

No swales shall be under drained unless into a contained (lined) piped system, or where infiltration is proven by the design risk assessment. See 2.12 below on piped filter trenches. Any under drain shall only be permitted where constructed within the final 3m of the downstream end of the swale in order to prevent waterlogging, and in compliance with the general concepts of the piped filter trench section of this specification.

6. Under-drained swales shall be permitted only where the Scottish Water specification for piped filter trenches is adhered to. In such instance the sacrificial layer in the base of the swale shall be either 75mm depth of topsoil or 300mm depth of stone.

Between 150mm and 300mm of topsoil shall be laid on top of the protective sand layer and liner, being topsoil to BS 3882:1994. In areas particularly prone to heave, the design of the liner shall consider lining with rigid or flexible concrete, and the choice of liner justified through the design risk assessment.

7. Where the overall slope of the swale is greater than 1 in 33 intermediate check dams shall be included in the design to increase residence time beyond the minimum average of 9 minutes, with check dams placed at least 10m apart and located such that any impounded level does not rise above the toe of the next upstream check dam or the apron of any inlet structures.
8. Any check dams or flow control devices shall be formed of tamper proof or fixed materials to prevent unauthorised use or removal. Loose stones shall not be permitted in case of unauthorised removal, although loose stone of 100mm to 600mm sizing may be used as infill to loose rock of mass greater than 30kg. Gabions, suitably secured and sustainable logs, stop boards / groyne, or gently sloping earth fill may also be used.
9. Check dams shall be constructed immediately downstream of a sump no more than 200mm deep below the base level of the swale. The sump shall have a length between 500mm and 1000mm upstream of the check dam, across the full horizontal width of the base of the swale, be lined with concrete or concrete pavements, and used to capture any localised sediments.
10. Scour aprons shall be provided downstream of all check dams for a minimum distance of 1000mm. These may be rock armour, gabion mattress, or vegetated erosion control matting.

### 2.11.5 Swale outlet structures

1. The outlet structure (i.e. flow control) shall include a man-entry chamber having minimal visual impact. It shall be designed to operate and discharge the design-limiting discharge rates in accordance with the Local Authority requirements as part of its flood prevention duties.

The outlet shall be designed to blend in with the surrounding landscape where possible. Mitred pipework with concrete collars, subject to the appropriate finishing, shall be permitted where depths and sizing permits. All outgoing pipework greater than 600mm shall be afforded a full headwall

All outgoing pipework/chambers shall include a sediment control device, such as a catchpit.

Appropriate hydraulic checks on the implications of high water levels in the receiving watercourse (on the effective operation of the outflow control) shall be made, where appropriate.

Throttle controls shall be provided using high-grade galvanised or stainless steel fixed to the concrete structure in such a way as to be tamper proof but allowing the opportunity for future modification and refining the operation of the control system.

The swale outlet shall be furnished with the ability to block the discharge of water in the event of pollution or similar incident – thereby preventing the spread of contamination downstream. This shall be by means of a tamper proof shut-off valve operated from surface level, or similar devices.

The minimum diameter of any limiting discharge control orifice shall be 75 mm unless otherwise agreed. Vortex control units or similar may be used to control outflow rates. Slotted or vee notch weirs may also be used.

If discharging to a receiving water, subject to the Local Authority requirements, the outlet structure control(s) shall discharge at the design 1-year return period outflow rate when the swale is at the 1-year return period water level for the critical design storm event. Similarly, this applies to the control for the 30-year return period and any greater return period event as required by the Local Authority as part of its flood prevention duties.

The full 1-in-30 year limiting flow rate can be discharged (within the constraints of head-discharge design) once the maximum water level of the 1-year return period event has been exceeded. Similarly, this applies to the control for the 30-year return period and any greater return period event as required by the Local Authority as part of its flood prevention duties. In all cases, flood routing shall be assessed for a 1-in-200 year event to ensure the integrity of the SUDS arrangements and their protection from erosion or associated risk.

The outlet structure shall include an integral overflow to enable pass forward flow in the event of blockage or other such event.

An emergency overflow shall be provided which shall enable design exceedance flows up to the 1 in 200 year event to discharge past / along the swale whilst not increasing the risk of detriment to the swale or its adjacent land.

Means shall be provided to drain the lowest point in the swale at the outlet in such case where the outlet has failed. A pipe may be laid to the lowest point in the swale and a valve at the same level be provided in the outlet chamber. The capacity of the drawdown function shall be no smaller than the capacity of the inlet pipe(s) to the swale. The penstock or other valving shall be able to be operated safely from ground level, outside of the outlet structure.

The top of the swale outlet headwall shall be a minimum 300 mm above the top water level of the maximum design return period storm event but no more than 100mm above surrounding ground level at that point.

### **2.11.6 Swale operation and maintenance**

1. A permanent safe maintenance-access route along at least one side of the swale shall be such that it is available in all weather conditions, and allows access for all relevant types of vehicles and equipment that may be required to operate and maintain it.
2. The access shall have a minimum width of 3.5m and shall be located above the maximum 30-year water level including allowances for climate change and increased paved areas.
3. The access shall provide (as a minimum) access to all inlet headwalls/chambers, the outlet headwall/chamber, and any in-channel control features including any check dams.
4. Vehicular access into the base of a swale is not specifically required, and shall not be provided near the outlet where the swale may be under-drained.
5. The design of the swale and surrounds shall include space for the removal and processing of excavated material (litter, debris, vegetation etc.), including adequate space for vehicle turning, loading, unloading and the safe movement and activities of our operatives.
6. The provision of tanker access and turning must be allowed in the event of severe pollution so that emptying can be achieved from the downstream outlet or other from any other intermediate control feature.
7. The outlet from swales shall be designed to permit the safe and easy clearing of blockages without the requirement for specialist plant or equipment.
8. Adjacent land shall not convey runoff onto the maintenance access route, and such runoff shall be intercepted by other appropriate land drainage which shall not be vested by Scottish Water.

### **2.11.7 Swale safety**

1. All swale structures should be evaluated for risk to the public, maintenance staff and wildlife. Health and Safety issues should be considered throughout the design process with the aim of delivering swales that are safe and easy to maintain.
2. The design risk assessment shall cover all relevant safety and environmental issues (e.g. pollution) for both operatives, local residents and environs. The swale designer shall demonstrate that measures have been taken to reduce the possibility of harm.
3. The design risk assessment shall address such issues as (but not be limited to):
  - Proximity of the swale to schools, nursery schools, old people's homes;
  - Proximity of the swale to public access leisure routes i.e. pedestrian pathways (including possible shared use of the maintenance access);
  - Known areas where there is a high degree of vandalism or fly tipping;
  - Children's play areas.
4. The design risk assessment shall take into consideration that a swale becomes a workplace from time to time during maintenance, as defined in the Health and Safety at Work etc. Act 1974. The adequacy of the risk assessment shall be demonstrated as part of the Local Authority planning application and the site's Drainage Health and Safety Plan provided under the Construction (Design and Management) Regulations.

Educational signs shall be provided at all swales in accordance with the findings of the design risk assessment. Signs denoting any infrequent and temporary flooding of the area shall be provided in line with the site-specific design risk assessment. In addition, reference shall be made to Scottish Water's SUDS Vesting Guidelines which provides further signage information on environmental aspects.

5. The maximum side slope between the maintenance access path and the swale base shall be a slope of 1:4 to allow easy maintenance access and egress.
6. A maximum slope of 1:12 shall be provided on any defined vehicular maintenance access route into the swale, where provided.
7. All vehicular access points shall be level, secure and stable.
8. All vertical drops greater than 1.2 m shall be protected using guardrails or similar fencing and based on the risk assessment. This is intended for the inlet and outlet headwalls only, with all other drops being accommodated by gentle landscaping.
9. The side/base of the swale may be planted with appropriate marginal species to achieve a high-density barrier when mature which effectively dissuades people from trying to gain access to any open water. Dense or tall vegetation (bushes and trees) around the external perimeter of the swale shall not be planted in order to afford a high level of visibility to the swale and ensure the performance of the swale liner.
10. Barrier fencing shall be considered as part of the initial design risk assessment at all swales although shall be the exception and not the default position (see CIRIA 753): in general, swales should not be fenced off. The requirement for any fencing must be considered carefully and proportionate to the site risk level. The design risk assessment shall address issues such as:
  - Proximity of the SUDS to schools, nursery schools, old people's homes;
  - Proximity of the SUD system to public access leisure routes i.e. pedestrian pathways;
  - Children's play areas.

Unrestricted visibility shall be afforded to all accessible swale features. Where young children can gain unsupervised access to more permanent water within the swale (eg behind any check dam) then a toddler proof fence 600-750mm high may be provided to discourage entry: the fence shall be a vertical plate type to prevent climbing on it.

11. All exposed pipe inlets or outlets which are larger than 350 mm shall have hinged safety/safety grilles installed. Grille designs shall be suitable to minimise the risk of blockage, have safe access for clearing during extreme events and prevent unauthorised access, particularly by children and pets. Bar spacing shall not exceed 150 mm and shall not be less than 75 mm to limit trapping small debris.
12. A typical safety grille and outfall is illustrated in Figures 8 and 9 respectively. Where grilles can be avoided by the use of appropriate design to restrict unauthorised access into the structures, this is preferred.

### **2.11.8 Swale amenity**

1. Suitable aesthetic considerations relating to protecting and enhancing landscape quality shall inform the design of the swale and its surrounds.
2. Erosion in the swale shall be controlled during the establishment of the planted vegetation by using jute, straw or geo synthetic mats.
3. The use of the swale for any sports or other activities shall not be encouraged.

### **2.11.9 Swale ecology**

1. Pipes, chambers, and other sumps in the landscape can be a hazard to wildlife as well as people. The risk to small mammals, reptiles and amphibians should be 'designed-out' where possible. The phenomenon, known as the 'gully pot issue', can be obviated by inclusion of wildlife ramps in sump features, to allow wildlife to crawl out.

2. Suitable native planting and variation in the physical characteristics of the swale shall be provided to maximise the ecological value of the swale and surrounds. These measures shall include the use of appropriate terrestrial species and take account of habitat plans in the local biodiversity plan for the area.
3. The swale shall be planted with grasses and other readily maintained species such that no specialist maintenance is required. Whilst a uniform planting regime across and along the swale is preferable, the design may consider, subject to the demonstration of hydraulic performance, marginal species along the base, where moisture conditions are appropriate. Species selection shall be made by suitably qualified professionals to ensure they are suitable to the conditions presented at the site.
4. No brush or other shrubby planting shall be permitted within 1m of either bank of the swale. No trees shall be planted within 5m of the swale edges unless root protection is provided.

Further guidance on appropriate planting can be obtained from the Local Authority, SEPA and Scottish Natural Heritage. See also CIRIA 753.

## **2.12 PIPED FILTER TRENCHES**

1. Piped filter trenches shall be implemented only as 'end of pipe' SUDS where intended for vesting by Scottish Water. Furthermore, this specification explicitly does not include for infiltration from the piped filter trench as a SUDS solution, nor to a piped filter trench being used to collect runoff solely from the surrounding land or highways. Piped filter trenches, as specified here, shall be used where required to provide a level of treatment in line with SEPA guidelines.

These 'end of pipe' filter trenches are the only type of piped filter trench that Scottish Water shall consider vesting.

The piped filter trench should be designed to store or convey the 1 in 30-year event.

The design and construction of piped filter trenches should be managed to ensure there are no sediments accumulated in the filter trench during the construction work or while in operation. As such, once filter material is installed, management of runoff shall be required until the site construction is completed.

### **2.12.1 Piped filter trenches configuration and dimensions**

1. All piped filter trenches shall include the following elements:
  - a) maintenance access, approximately 3.5 m wide, to all inlets and outlets and any intermediate chambers, suitable for a vehicle and trailer;
  - a) an inlet structure with a shut off facility; and a sediment control device (e.g. catchpit), or upstream sediment management;
  - b) an outlet structure with an integral overflow and shut off facility. The storage capacity of the trench can only be considered as part of the design where the outlet from or intermediate control from the filter trench is regulated;
  - c) A stone filled trench, being either visible, or buried, at the surface, and in all cases lined with an impermeable membrane.
  - d) Intermediate chambers to limit the continuous piped length to a maximum of 90m;
  - e) A separate continuous perforated inlet (overflow) pipe within the upper layers of the stone filled trench;
  - f) A separate continuous perforated outlet (drain) pipe within the lower layers of the stone filled trench, being at least 500mm below the inlet / overflow pipe;

- g) a separate spill overflow structure (with a planned flood route).

The dimensions of the piped filter trench shall be based on:

- b) a maximum depth to invert of 3000mm;
- c) a minimum depth to invert of 1500mm;
- d) a minimum base width being the greater of 500mm or three times the diameter of the inlet pipes;
- e) a maximum base width of 3000mm;
- f) a maximum longitudinal gradient of 1:50 shall be permitted;
- g) the self-cleansing flow velocity of 0.75m/s to 1m/s shall be designed for the peak flow at the 1-year return period event;

### **2.12.2 Piped filter trench location**

1. All piped filter trenches shall be located at suitable topographic locations in passive public open space and with a vehicular access to the inlets, outlets and any intermediate chambers. Furthermore, the piped filter trench shall be separated from the edge of the filter trench by at least 2m from the nearest private land boundary, being the distance from the edge of the trench to the boundary.

Vehicular access onto the filter drain should be prevented to avoid damage and compaction of the stone fill material.

2. Where not part of the drainage design, any external flows e.g. land drainage/ groundwater that might discharge into the piped filter trench must be intercepted: the design should consider the requirement for additional interception features to convey these flows.

Where a piped filter trench is intended to collect sheet surface flows, stone shall be used to ground level and the edge of the filter trench should be levelled with the surrounding surfaces. The design risk assessment shall include all relevant safety issues associated with maintaining the surrounding land where an open stone piped filter trench is located with particular consideration of grass mowing.

Where specifically not intended to collect flows from the ground surface, the top of the piped filter trench shall be buried beneath a layer of topsoil. An impermeable separation membrane shall be used to prevent the migration of surface water and sediments into the stone. This design allows for the surface to be landscaped and planted – although vegetation shall be limited to grasses and wildflowers. This form of piped filter trench provides better visual amenity and biodiversity benefits, but is not used where surface water infiltration is required. Scottish Water shall not vest any land drainage, nor any feature that accepts land drainage, and the design shall include for the separation of such flows from the vested system.

Vandalism and the longevity of the piped filter trench shall be taken into account during the design, associated both with its day to day performance, and the required maintenance activities. Where vandalism is possible, use of a partially buried gabion mattress shall be made to prevent loss of the stone material.

3. The maximum flood water level in any piped filter trench shall be at least 500 mm below the floor level of any adjacent premises.

In designing and locating the piped filter trench, developers shall also demonstrate flow paths and the potential effects of surface flooding resulting from storm events exceeding the design criteria. Developers shall follow the guidance provided in the statutory guidance document 'Delivering Sustainable Flood Risk Management: Guidance Document (2011) and any surface water management plan that may have been developed by the relevant Local Authority.



4. The maximum 1-year return period event water level in the piped filter trench shall be higher than the appropriate return period event water level of the receiving watercourse, or sewer and SUDS, as specified by the relevant Authority. Hydraulic checks on the implications of high watercourse levels on the piped filter trench shall be made, where appropriate.

### **2.12.3 Piped filter trench inlet structures**

1. The inlet structure to a piped filter trench shall include a man-entry chamber. All incoming flows shall connect to a chamber and not into the filter trench itself.
2. The invert(s) of all the incoming sewers to the inlet chamber shall be at or above the maximum 1-year water level in the piped filter trench (making due allowance for climate change and allowance for increased paved areas through urban creep).
3. The invert of the lower (outlet / drain) pipe shall be no more than 90mm and no less than 75mm above trench invert. This pipe shall be closed at the inlet structure by use of a bung, valve or other proprietary pipe product, tamper proof and suitable for secure/safe opening/removal from ground level.
4. The inlet structure, or structures, shall include for a sediment catchpit or other sediment control device unless sediment is otherwise intercepted and managed upstream of the SUDS. The sediment control shall be designed to minimise sediment passing into the piped filter trench.
5. Sediment controls serving residential areas shall be sized to allow 1 year's worth of sediment storage based on 0.3m<sup>3</sup> per hectare, based on hectares of impermeable (including roofed and paved) area. Those piped filter trenches serving industrial and commercial areas shall have their controls sized to allow 1 year's worth of sediment storage based on 0.8m<sup>3</sup> per hectare.
6. Where the incoming pipe is greater than 600mm diameter, the design shall consider the use of multiple continuous pipes along the trench (multiple distribution and collection pipes). All incoming pipework greater than 900mm shall incorporate the use of multiple continuous pipes along the trench.
7. The inlet pipe(s) shall be furnished with the ability to block the discharge of water in the event of pollution or similar incident – thereby preventing the spread of contamination into the filter material. This shall be by means of a tamper proof shut-off valve operated from surface level, or provision for stop logs (to be supplied to Scottish Water on Vesting) or similar devices.
8. Multiple pipes shall start and end at man entry chambers. The inlet chamber shall be designed to blend in with the surrounding landscape and be fully accessible.
9. Where long-term storage, which is not vested in Scottish Water, is to be provided beyond the 1-in-30 year storm level, or from the piped filter trench to other SUDS features, flows shall be diverted from the inlet structure.

### **2.12.4 Piped filter trench & water quality design criteria**

1. In a piped filter trench hydrocarbons and organics are broken down by the biofilms that grow on the surface of the stone in the trench: as the pipe surcharges into the trench, attenuation is provided by the voids in the media and the surfaces provide treatment. The performance of the SUDS is determined by the design of the trench.
2. An easily removed separation geomembrane shall be used to trap sediment near the surface of the drain. This membrane shall be buried by a sacrificial stone or topsoil layer of 300mm, and anchored outside the trench liner to ensure no migration of materials into the trench.

3. The sacrificial stone shall be a single size clean stone of nominal size 40mm. A gabion mattress basket shall be used to enclose the stone where the design risk assessment indicates that the risk of vandalism is high.
4. A continuous perforated inlet / overflow pipe shall be installed no higher than 600mm below the ground surface. All perforated pipework shall conform to the relevant harmonised European Standards (EN), having a CE mark and being third party tested by, for example, British Board of Agrément (BBA). This pipe shall promote the filtration of water through the stone to the lower outlet / drain pipe and, in the event where the storage volume of the trench is exceeded, act as an overflow carrier.
5. All pipework through the trench shall be fully perforated pipework of nominal diameter no less than 150mm. All perforated pipework shall conform to the relevant harmonised European Standards (EN), having a CE mark and being third party tested by, for example, British Board of Agrément (BBA).
6. No trench or pipework shall be laid at a gradient steeper than 1 in 50 to promote stable conveyance of water through the stone, rather than along its base. The minimum gradient for pipework shall be 1 in 200 to minimise sedimentation.
7. All pipework shall be laid in accordance with the relevant pipe bedding details. of this document, on pipe bedding Distribution pipework shall be formed of long radius natural curvature pipework. Elbow bends shall not be permitted unless suitable rodding/jetting access is provided for.
8. The perforated outlet / drain pipe shall be laid no more than 90mm and no less than 75mm above the invert level (liner) of the trench.
9. The perforated outlet / drain pipe shall be laid no less than 500mm below the inlet / overflow pipe to provide sufficient levels of pollutant removal.
10. An intermediate catchpit chamber with sediment sump shall be constructed online to assist maintenance. No continuous pipe run shall exceed 90m. These access chambers and sumps should always be accessible and clearly identifiable.
11. The stone used to fill the filter trench shall be typically single sized granular clean stone of between 20mm and 60mm with a void ratio of 20% to 40%. Filter drains shall be backfilled as described in Clause 505, Appendix 5/1 of the Specification for Highway works with Type B filter material, which shall consist of natural or recycled coarse aggregate or recycled concrete aggregate complying with BS EN 13242 and geometrical requirements in accordance with Table 5/5 and BS EN 13242.
12. Piped filter trenches shall be made watertight using an appropriate impermeable liner, regardless of soils and underlying geology. The liner material shall be a single layer of butyl compound or polythene. If polythene is used, it shall in addition be protected by a geomembrane. The membrane liner shall be at least 0.75mm thick having a minimum tensile strength of 18N/mm<sup>2</sup> and puncture resistance of a minimum of 150N. A permeability coefficient of less than  $1.8 \times 10^{-12}$ m/s is required. Infiltration through the base, sides or even the top of the trench shall not be permitted.
13. Where infiltration through the top of the trench is to be prevented, the impermeable trench liner shall be wrapped over the full width of the trench such that the joint, with a minimum lap of 300mm, appears along a side wall. Longitudinally, the liner shall have minimum laps of 300mm and be jointed using twin seam fusion welding in accordance with manufacturer's recommendations. Extrusion welding shall not be permitted except where twin seam welding is inappropriate.
14. The liner shall be protected from the surrounding ground by a minimum 50mm of soft clean sand complying with Part 4 (Engineering specification) of Sewers for Scotland v4.0, or a puncture

resistant membrane conforming to BS EN 13252:2014 to prevent damage. If a polythene liner is used, it shall in addition be protected by a non-woven needle punched geomembrane with a minimum thickness of 3.5mm and minimum static puncture strength of 2.5kN in accordance with BS EN ISO 12236, and tensile strength of 15kN/m under BS EN ISO 10319. A minimum overlap for the protection membrane shall be 300mm.

15. The liner shall follow the invert of the trench and be laid no more than 90mm below the invert of the lowest outgoing pipe or control.
16. The liner shall be terminated between 300mm and 150mm below the surrounding ground level.

#### **2.12.5 Piped filter trench outlet structures**

1. The outlet structure (i.e. flow control) shall include a man-entry chamber having minimal visual impact. It shall be designed to operate and discharge the design-limiting discharge rates in accordance with the Local Authority requirements as part of its flood prevention duties.
2. The outlet shall be designed to blend in with the surrounding landscape and be fully accessible.
3. Appropriate hydraulic checks on the implications of high water levels in the receiving watercourse (on the effective operation of the outflow control) shall be made, where appropriate.
4. Throttle controls shall be provided using high-grade galvanised or stainless steel fixed to the concrete structure in such a way as to be tamper proof but allowing the opportunity for future modification and refining the operation of the control system.
5. The outlet pipe shall be furnished with the ability to block the discharge of water in the event of pollution or similar incident – thereby preventing the spread of contamination downstream. This shall be by means of a tamper proof shut-off valve operated from surface level, or provision for stop logs (to be supplied to Scottish Water on Vesting) or similar devices. The outlet structure shall also have an overflow to enable pass forward flow in the event of blockage or other such event.
6. The minimum diameter of any limiting discharge control orifice shall be 75mm unless otherwise agreed. Vortex control units or similar may be used to control outflow rates. Slotted or vee notch weirs may also be used.
7. The outlet structure / flow control chamber shall include an integral overflow to enable pass forward flow in the event of blockage or other such event.
8. In all cases, flood routing shall be assessed for a 1-in-200 year event to ensure the integrity of the SUDS arrangements and their protection from erosion or associated risk. A separate emergency overflow shall be provided which shall enable design exceedance flows to discharge whilst not increasing the risk of detriment to the trench or its adjacent land.
9. The top of the piped filter trench outlet chamber shall be no more than 100mm above surrounding ground level at that point.

#### **2.12.6 Piped filter trench operation and maintenance**

1. A separation geomembrane lid to the top of the trench shall be included to prevent the ingress of fines and separate the sacrificial stone layer from the rest of the trench. Where infiltration through the top of the trench is to be prevented, the impermeable trench liner shall be wrapped over the full width of the trench such that the joint, with a minimum lap of 300mm, appears on a side wall.
2. A permanent safe 3.5m wide maintenance-access route, with adequate turning, to the inlet(s), outlet and any intermediate chambers shall be constructed such that it is operational in all

weather conditions and above the 1 in 30 year water level including climate change. The route shall allow access for all relevant types of vehicles and equipment that may be required to operate and maintain the SUDS.

3. The access shall have a minimum width of 3.5m and shall be located above the maximum 30-year water level in the trench, including allowances for climate change and increased paved areas.
4. Sufficient access shall be enabled to permit the occasional need to remove and replace the stone filter material. This shall require infrequent vehicular entry along the trench and as such the design shall ensure suitable access and egress points.
5. The design of the piped filter trench and access shall include space for vehicle turning, loading, unloading and the safe movement and activities of our operatives, but prevent vehicular access onto the trench itself.
6. The provision of tanker access, and turning, must be allowed in the event of severe pollution so that emptying can be achieved from the downstream outlet.
7. Piped filter trenches shall be designed to permit the safe and easy clearing of blockages without the requirement for specialist plant or equipment.
8. Adjacent land shall not convey runoff on to the maintenance access route, and shall be intercepted by appropriate land drainage not vested in Scottish Water.

#### **2.12.7 Piped filter trench safety**

1. All piped filter trench structures should be evaluated for risk to the public, maintenance staff and wildlife. Health and safety issues should be considered throughout the design process with the aim of delivering piped filter trench that are safe and easy to maintain.
2. The design risk assessment shall cover all relevant safety issues for operatives, local residents and wildlife. The designer shall demonstrate that measures have been taken to reduce the possibility of harm or injury.
3. The design risk assessment shall address such issues as, but not be limited to:
  - known areas where there is a high degree of vandalism or fly tipping;
  - children's play areas; and
  - maintenance of open stoned trenches with regards litter removal, mowing and vegetation management.

All vehicular access points shall be level, secure and stable.

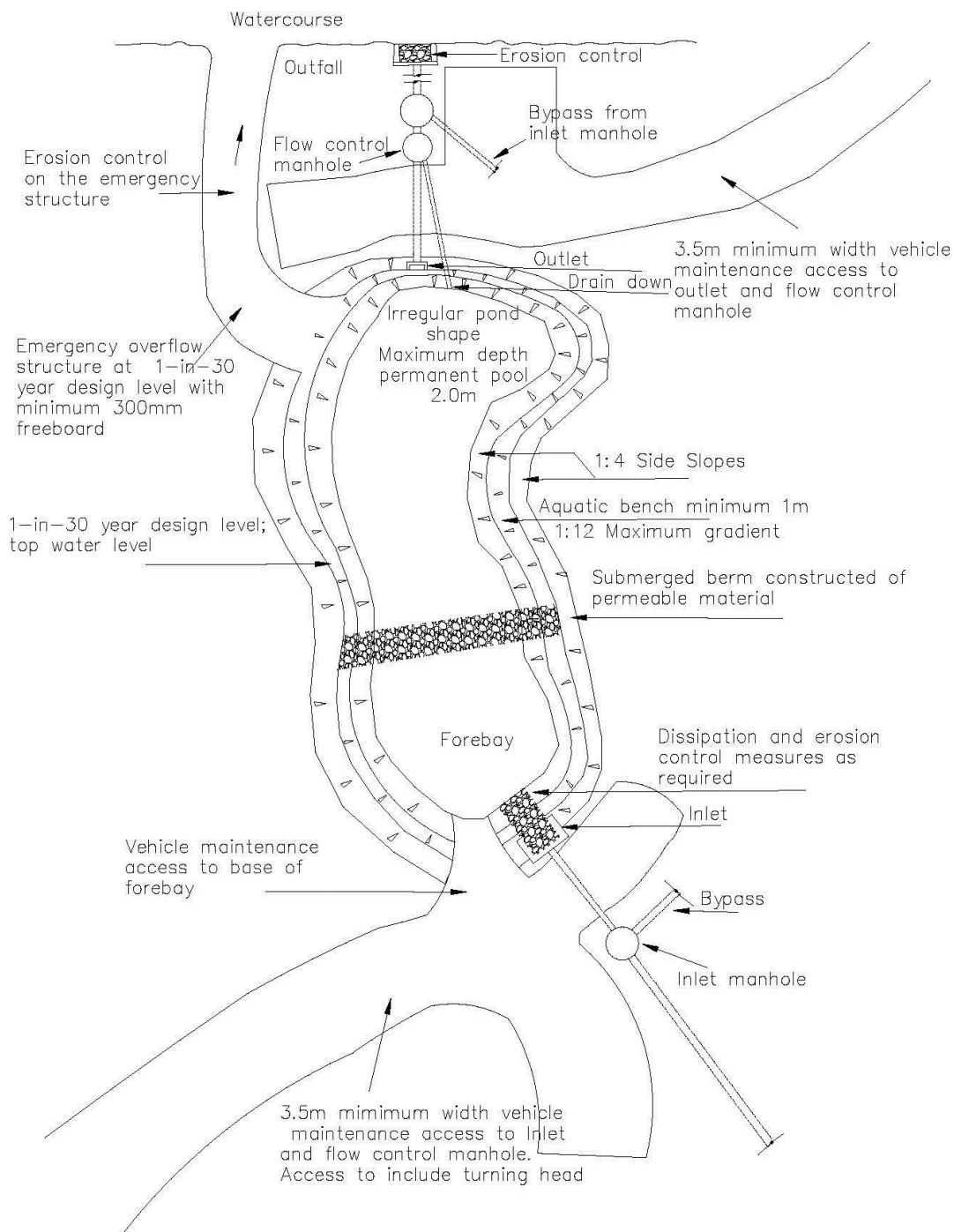
#### **2.12.8 Piped filter trench amenity**

1. Suitable aesthetic considerations relating to protecting and enhancing landscape quality shall inform the design of the piped filter trench and its surrounds.

#### **2.12.9 Piped filter trench ecology**

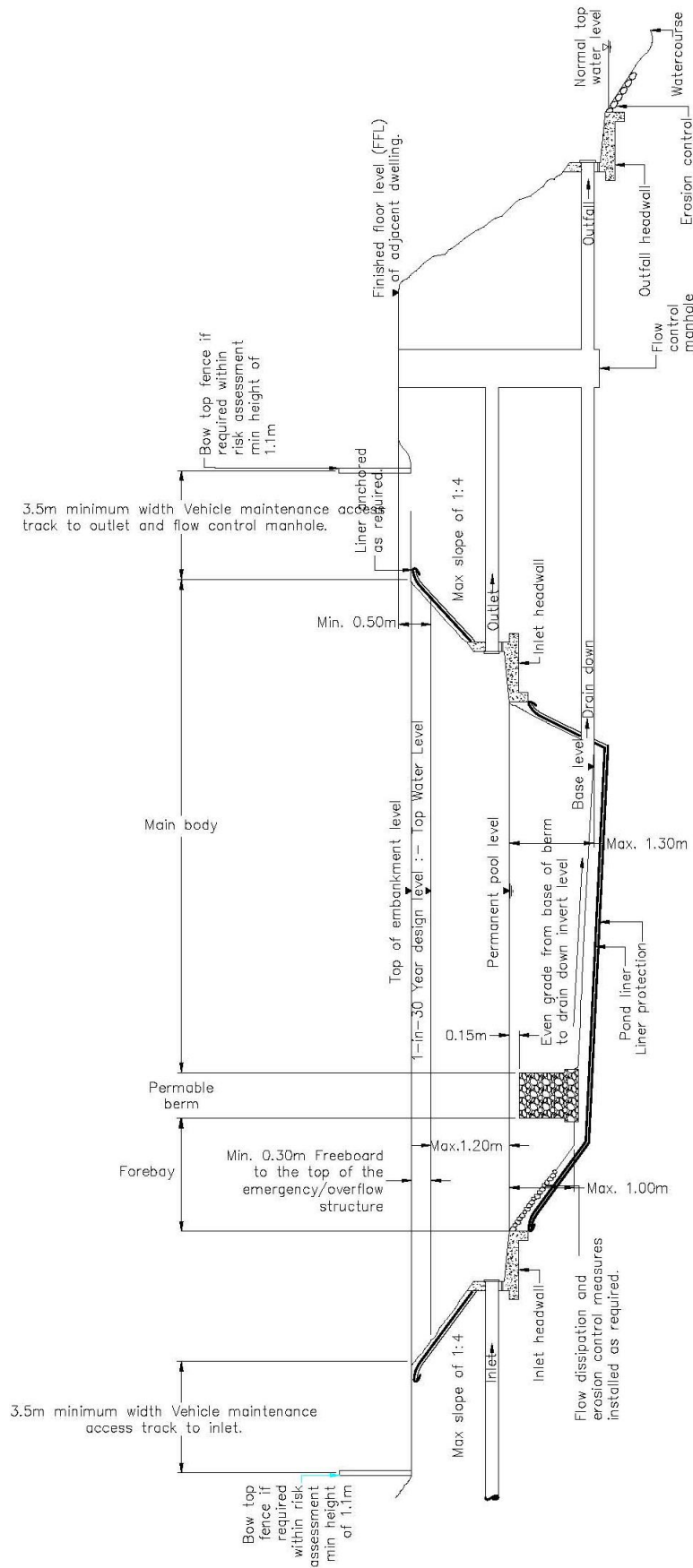
1. Suitable native planting and variation in the physical characteristics of the piped filter trench shall be provided to maximise the ecological value of the filter trench and surrounds. These measures shall include the use of appropriate terrestrial species and take account of habitat plans in the local biodiversity plan for the area. Further guidance on appropriate planting can be obtained from the Local Authority, SEPA and Scottish Natural Heritage.

**FIGURE 1  
POND LAYOUT**



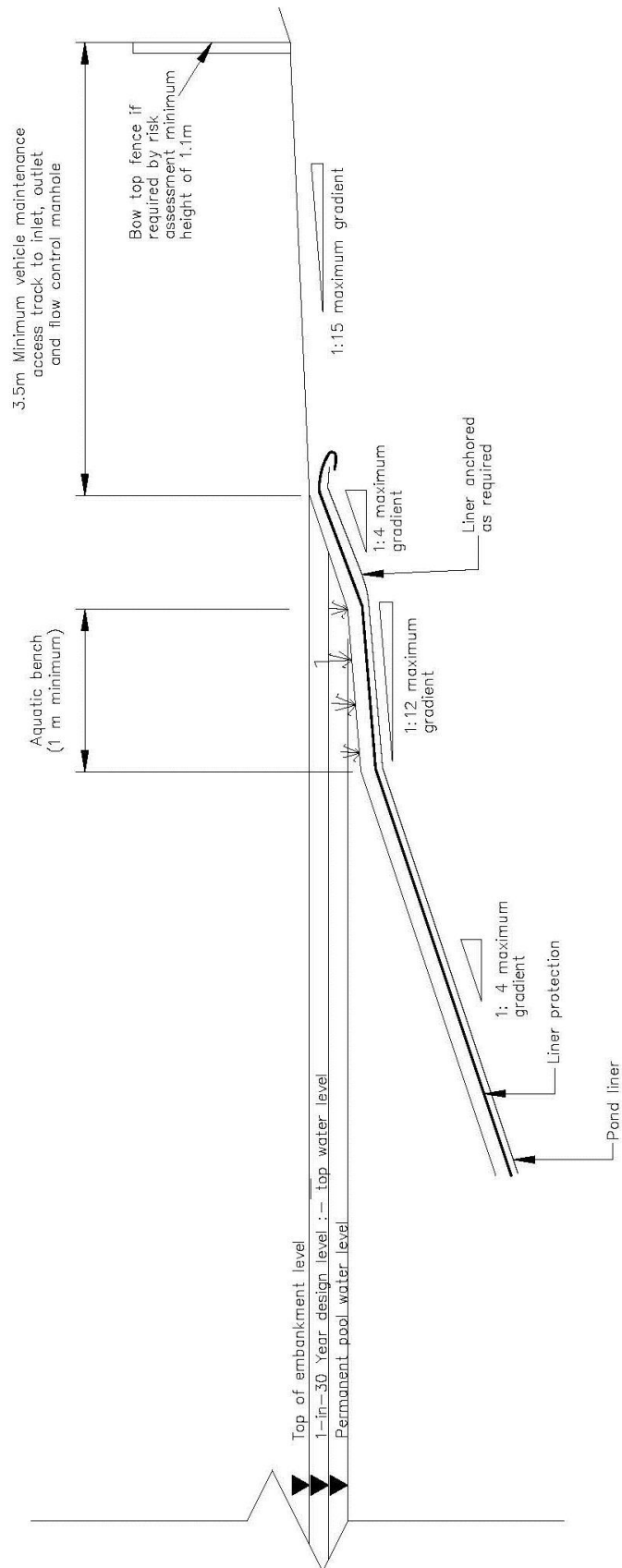
Not to Scale, dimensions in millimetres  
Full set and standard details, please contact Scottish Water

**FIGURE 2  
TYPICAL POND CROSS-SECTION**



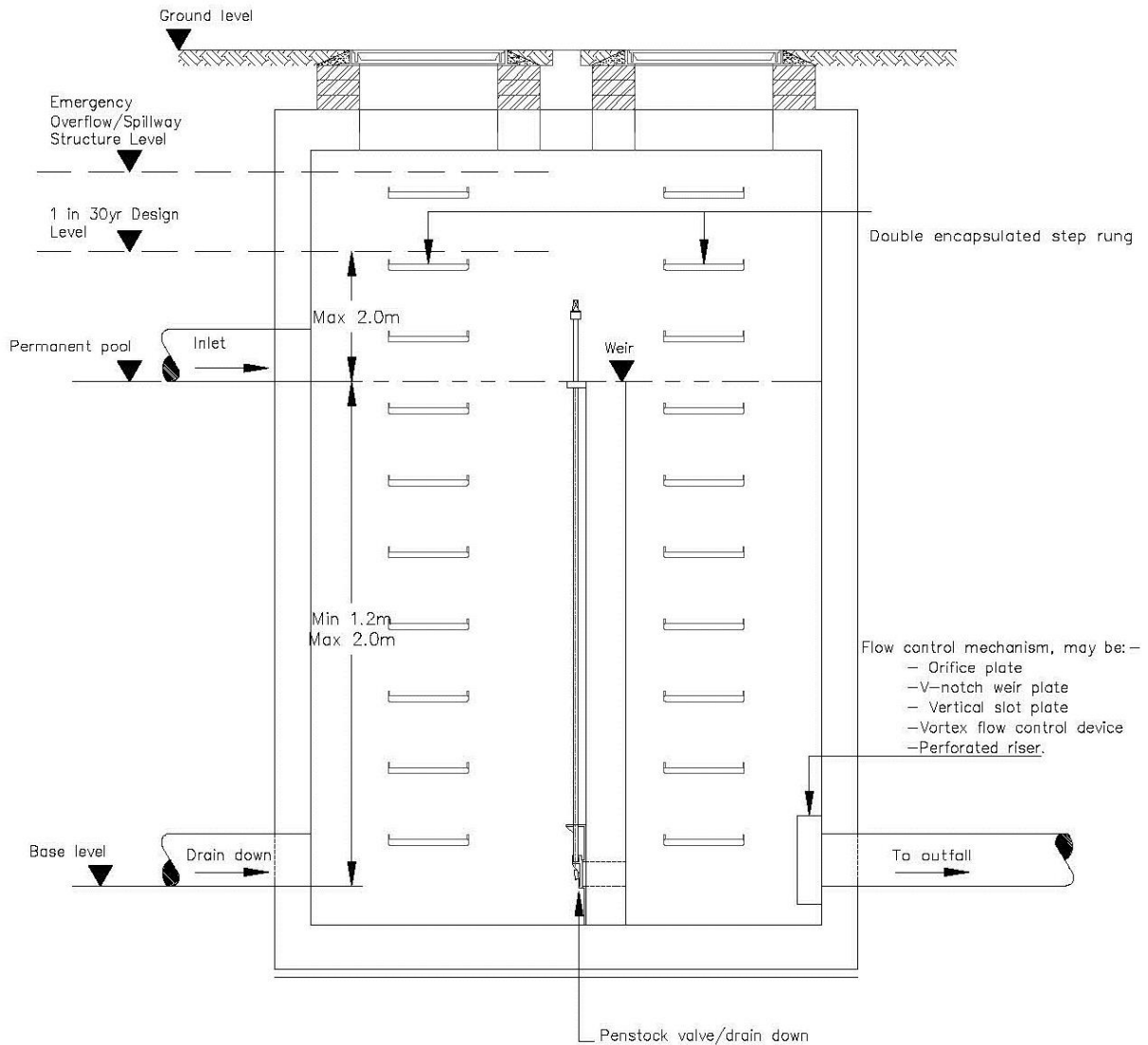
Not to Scale, dimensions in millimetres  
Full set and standard details, please contact Scottish Water

**FIGURE 3**  
**TYPICAL CROSS-SECTION THROUGH POND AQUATIC BENCH**



Not to Scale, dimensions in millimetres  
 Full set and standard details, please contact Scottish Water

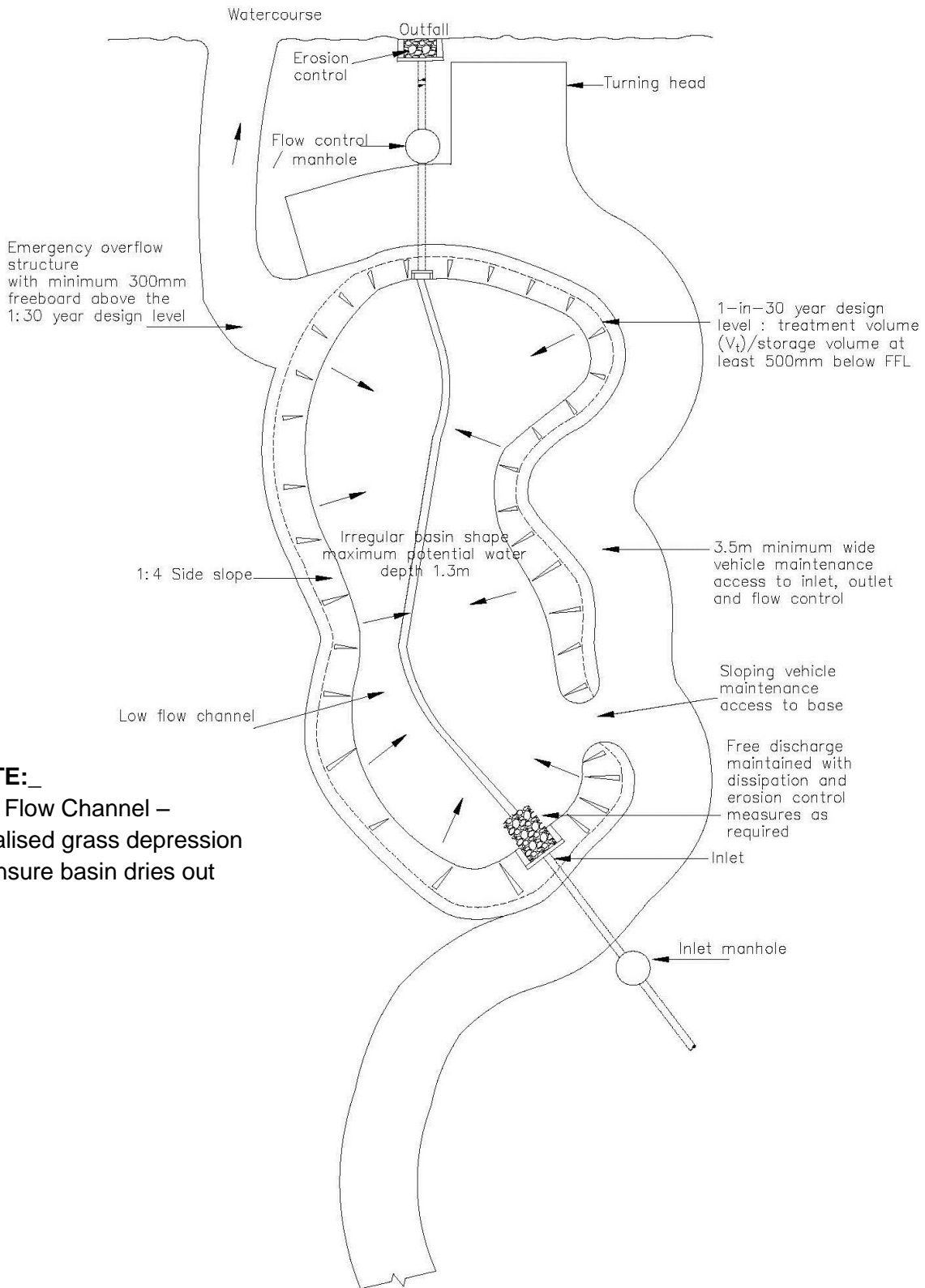
**FIGURE 4  
TYPICAL POND FLOW CONTROL MANHOLE**



Not to Scale, dimensions in millimetres  
Full set and standard details, please contact Scottish Water



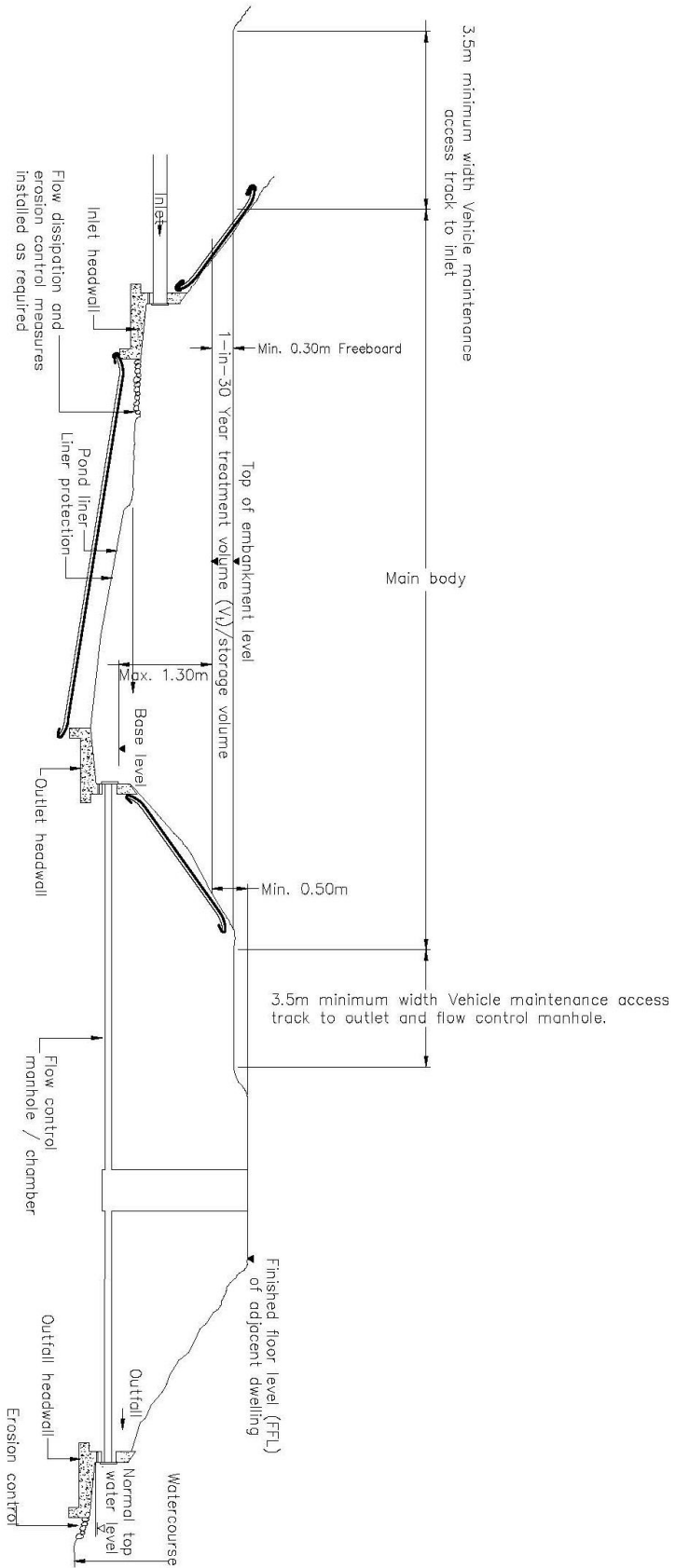
**FIGURE 5  
TYPICAL BASIN LAYOUT**



**NOTE: \_**  
**Low Flow Channel –**  
**Localised grass depression**  
**to ensure basin dries out**

Not to Scale, dimensions in millimetres  
 Full set and standard details, please contact Scottish Water

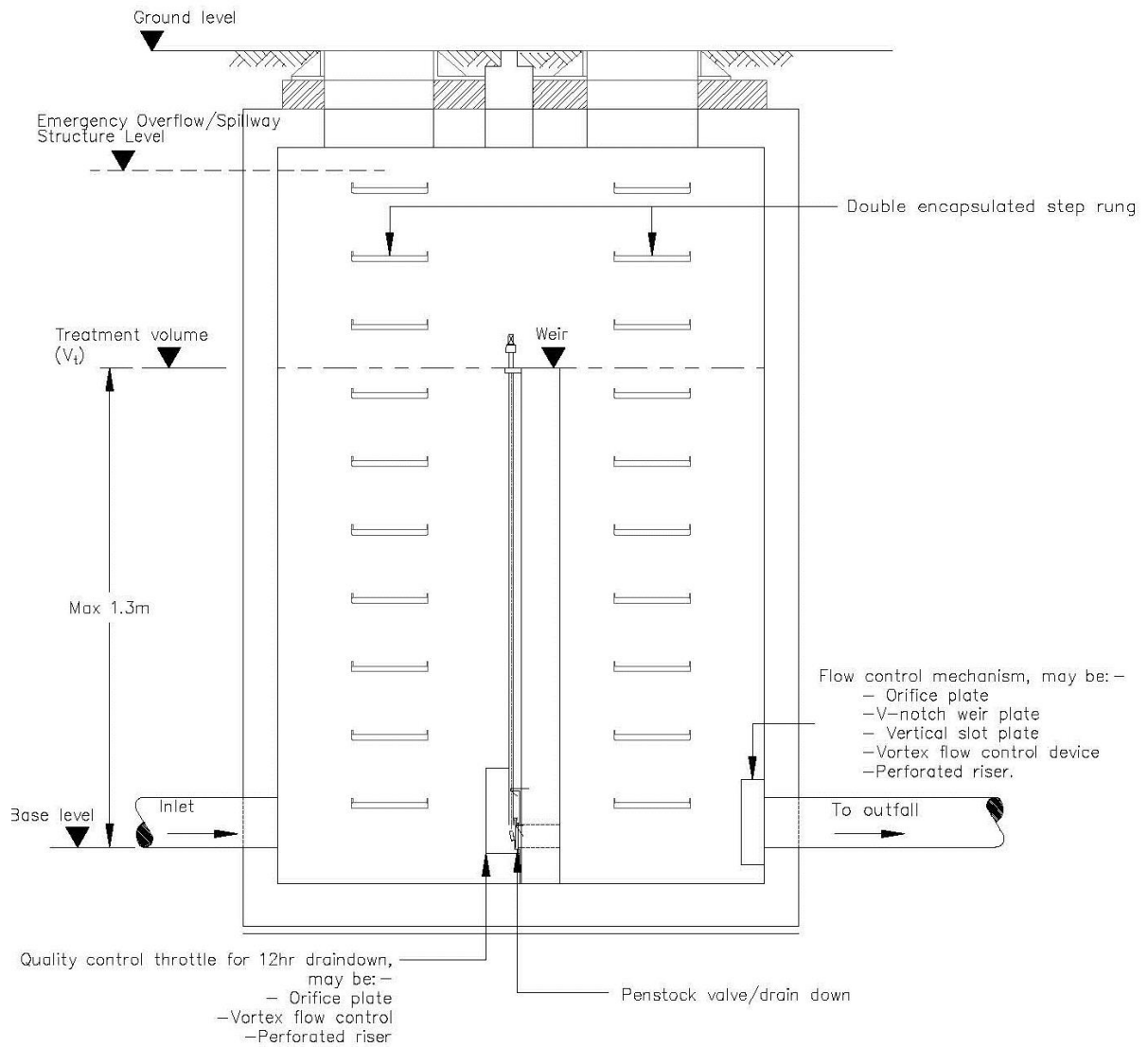
**FIGURE 6  
TYPICAL BASIN CROSS-SECTION**



**NOTE:-**  
Ref. CI 2.10.6.3 – Basin liners are only to be used in areas of high groundwater ie within 500mm of base.

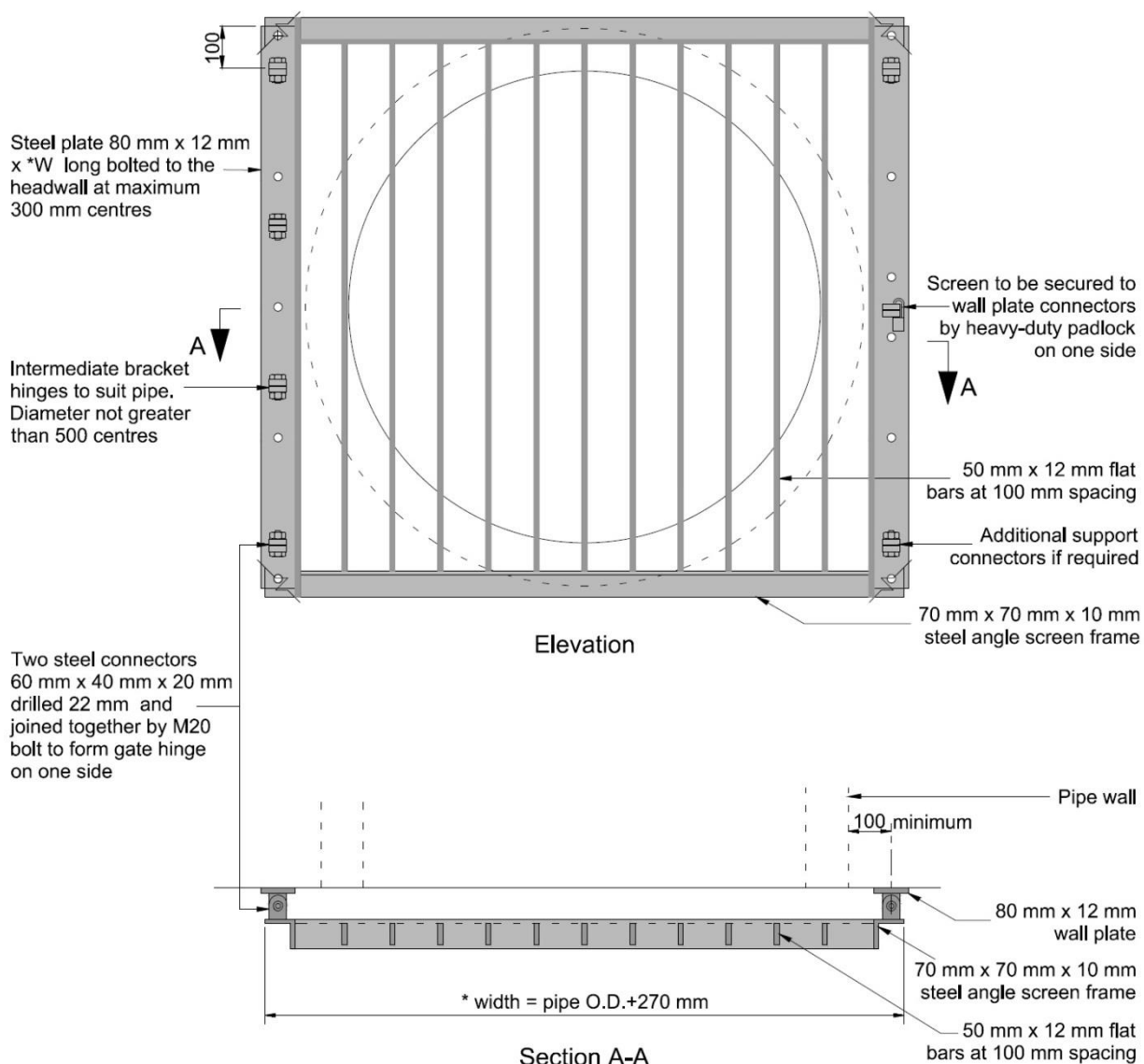
Not to Scale, dimensions in millimetres  
Full set and standard details, please contact Scottish Water

**FIGURE 7  
TYPICAL BASIN FLOW CONTROL MANHOLE**



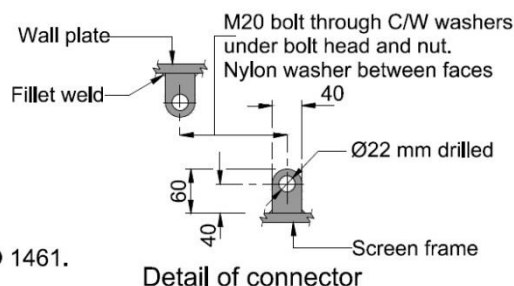
Not to Scale, dimensions in millimetres  
 Full set and standard details, please contact Scottish Water

**FIGURE 8  
TYPICAL OUTFALL SAFETY GRILL  
FOR OUTFALLS 350mm DIA OR GREATER**



**Notes:**

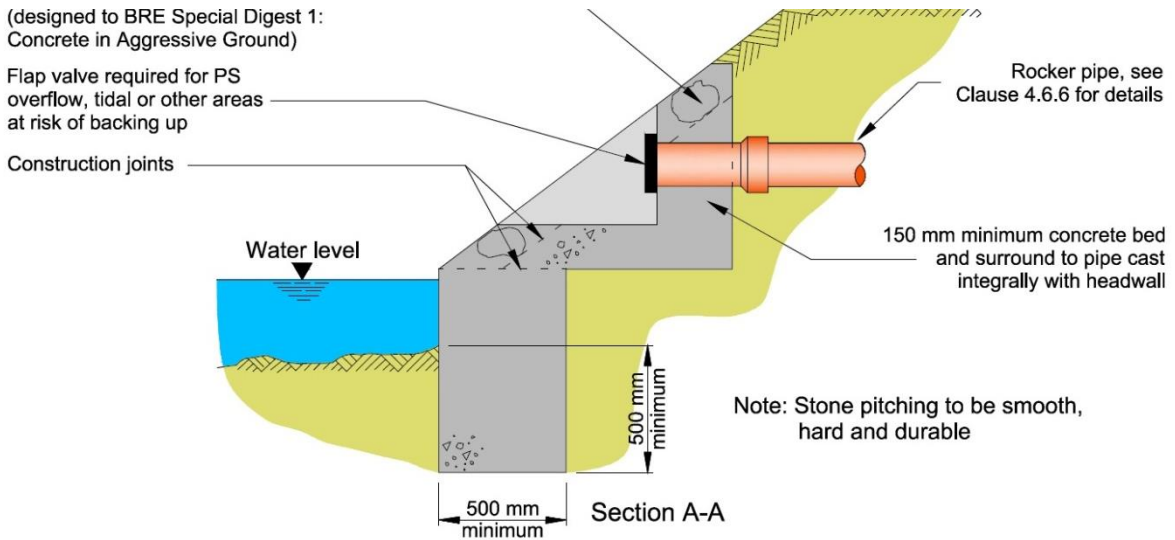
1. \* width (W) to suit pipe outside diameter.
2. Mild steel fabrication to be hot dip galvanised to BS EN ISO 1461.



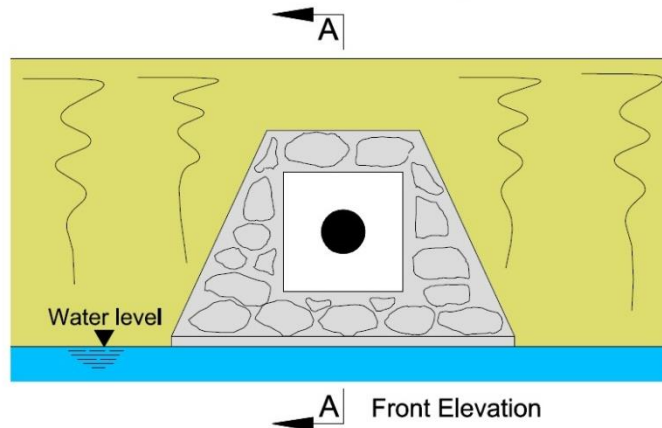
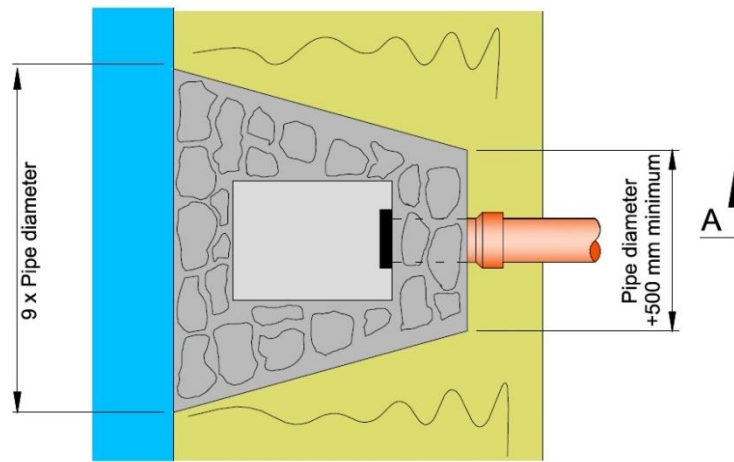
Not to Scale, dimensions in millimetres  
Full set and standard details, please contact Scottish Water

**FIGURE 9**  
**Typical Outfall to Water Course**

**Suitable for outfall pipes of less than 350mm**

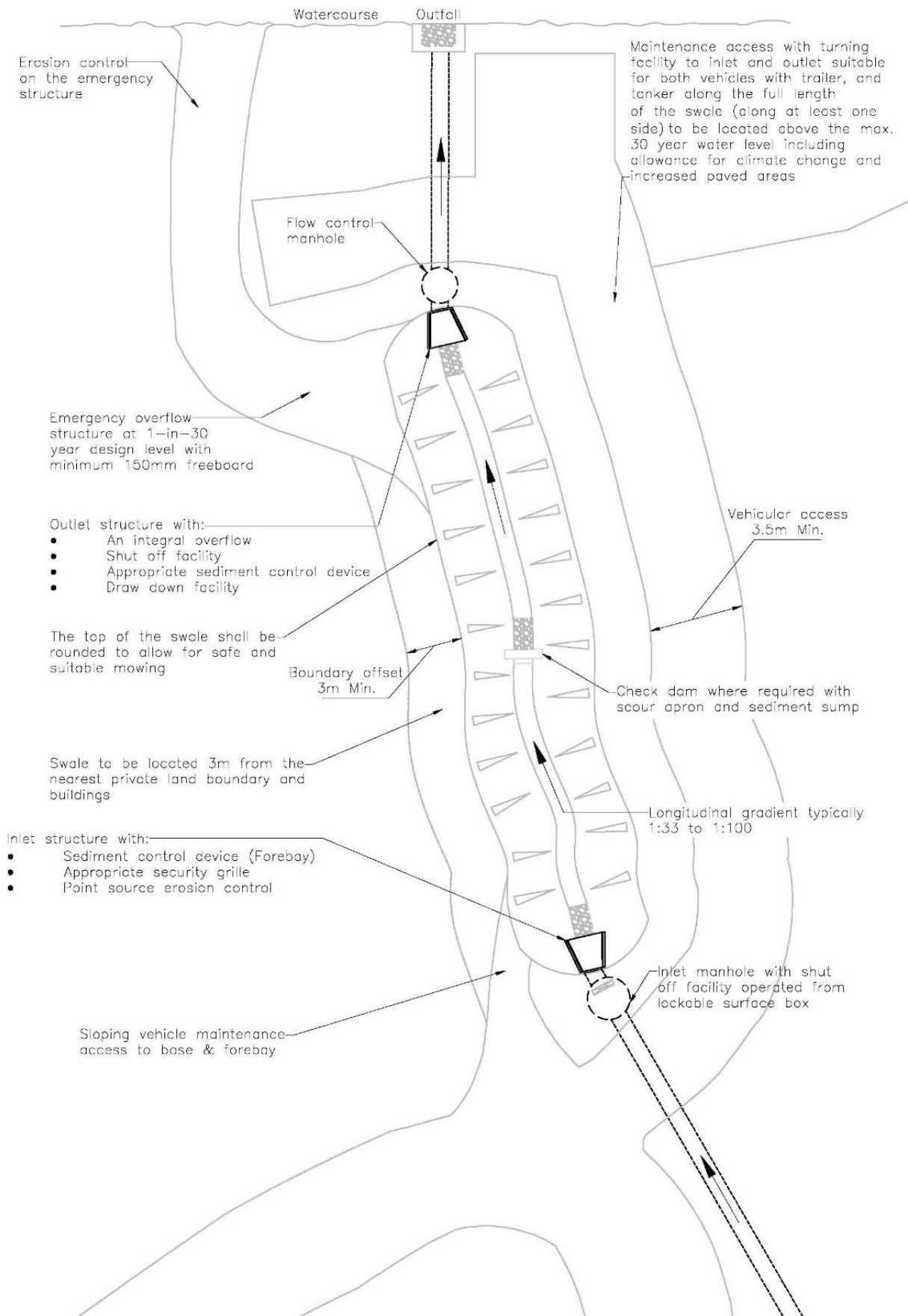


**NOTE:-**  
 Where site layout permits, the Outfall arrangement should be positioned 45 degrees to the direction of flow



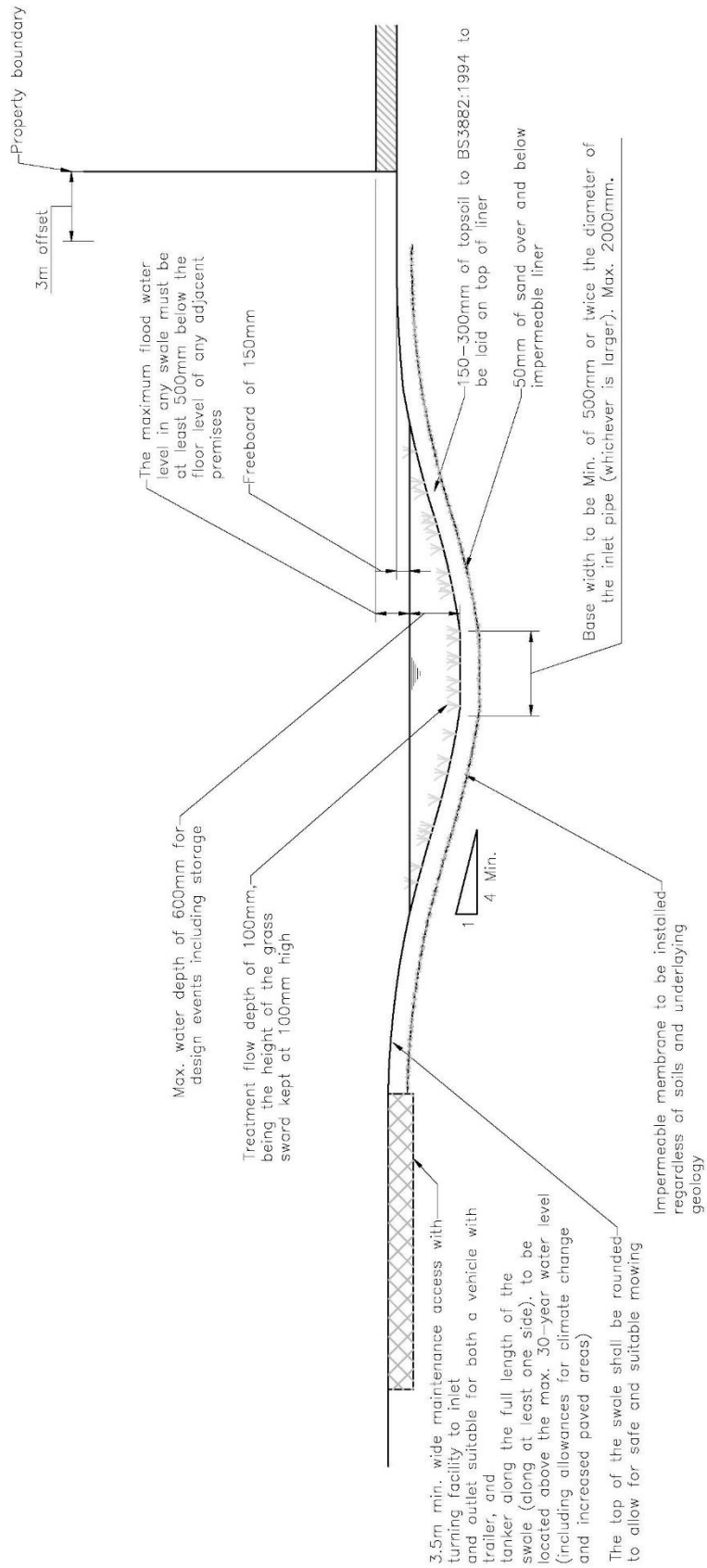
Not to Scale, dimensions in millimetres  
 Full set and standard details, please contact Scottish Water

**FIGURE 10  
TYPICAL PLAN OF SWALE**



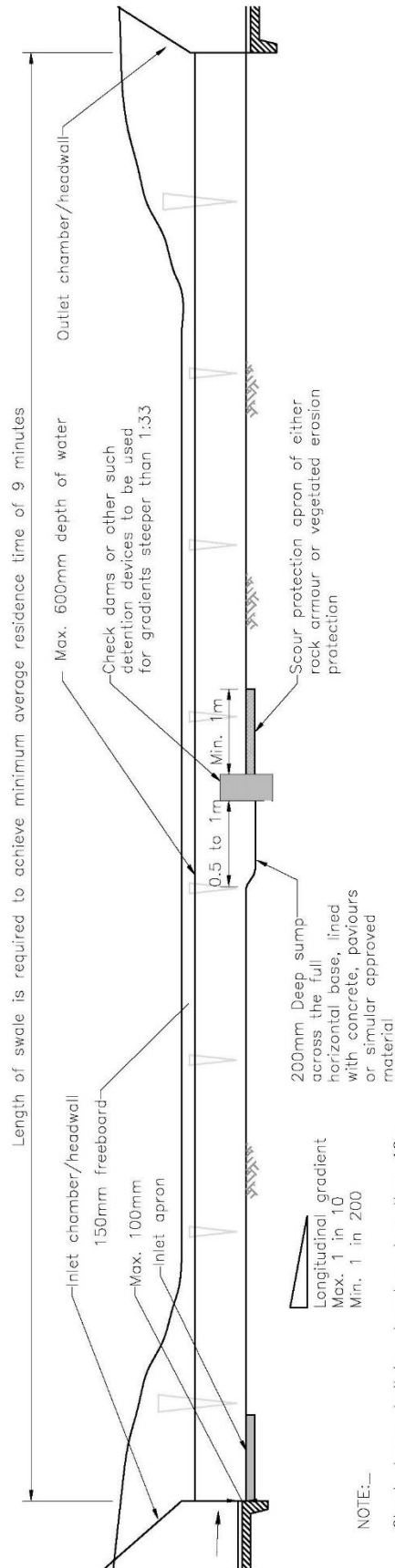
Not to Scale, dimensions in metres  
Full set and standard details, please contact Scottish Water

**FIGURE 11  
TYPICAL SWALE CROSS-SECTION**



Not to Scale, dimensions in millimetres  
Full set and standard details, please contact Scottish Water

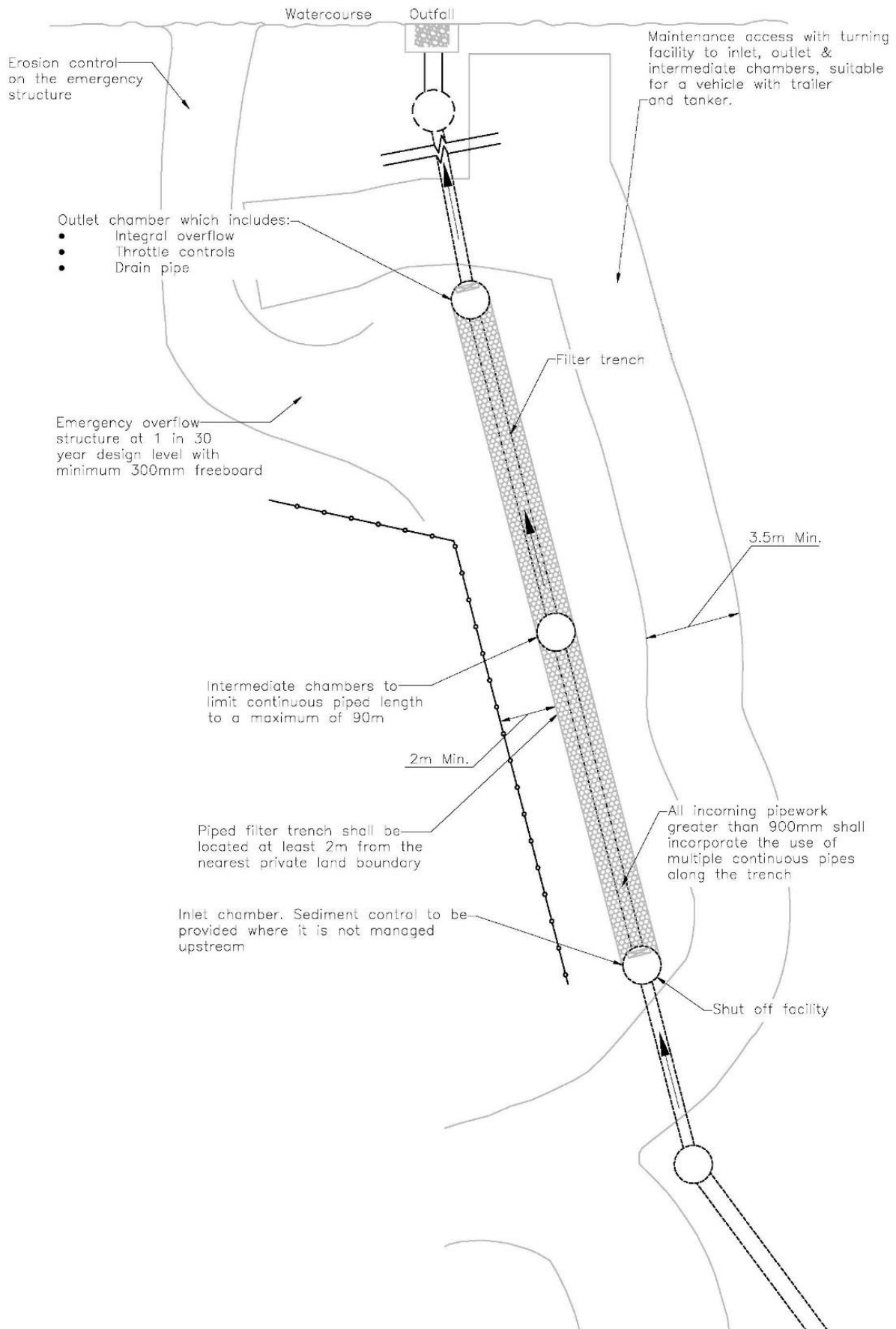
**FIGURE 12**  
**TYPICAL SWALE AND CHECK DAM LONG-SECTION**



Not to Scale, dimensions in millimetres  
 Full set and standard details, please contact Scottish Water

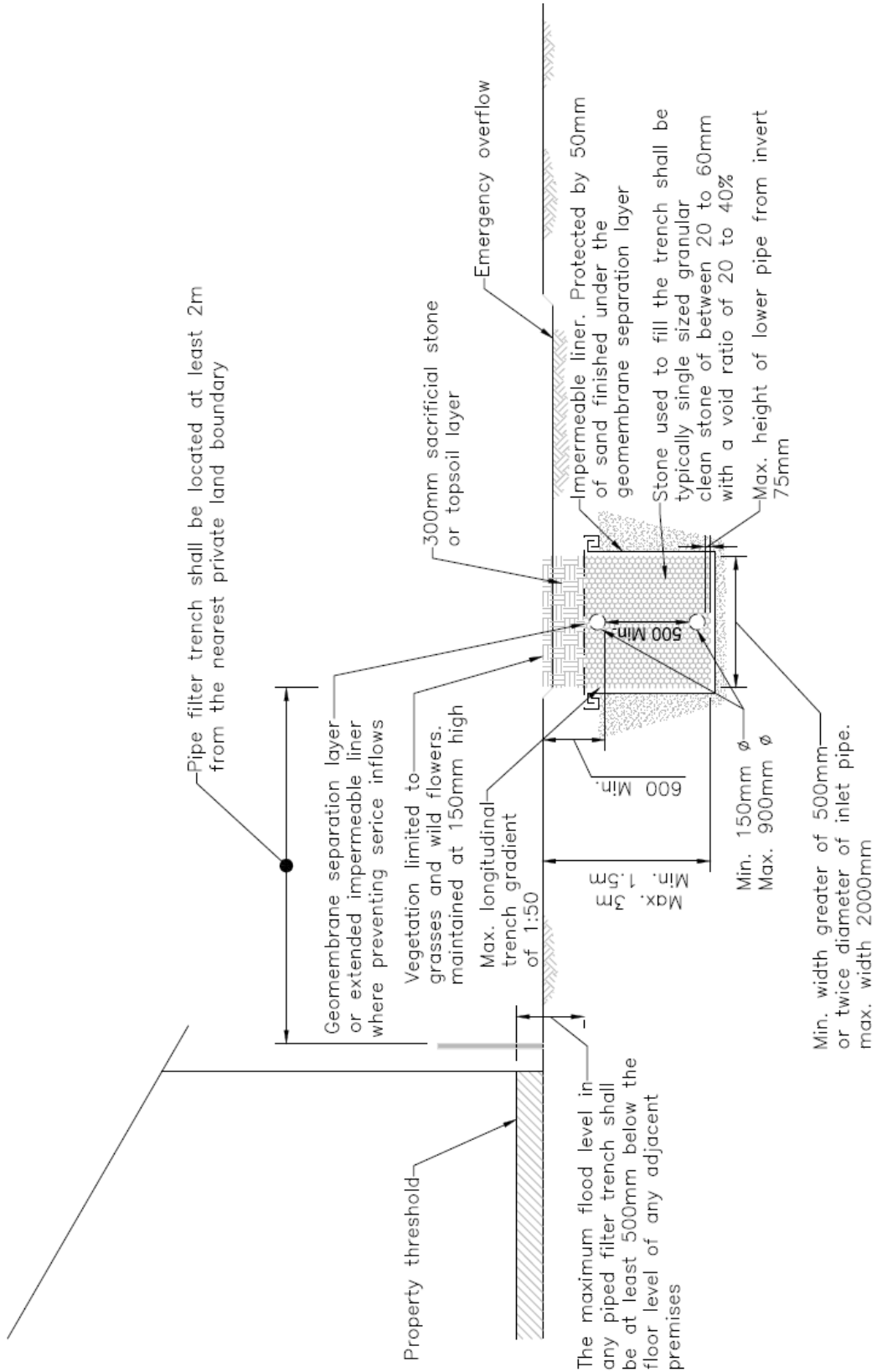


**FIGURE 13  
TYPICAL PLAN OF PIPED FILTER TRENCHES**



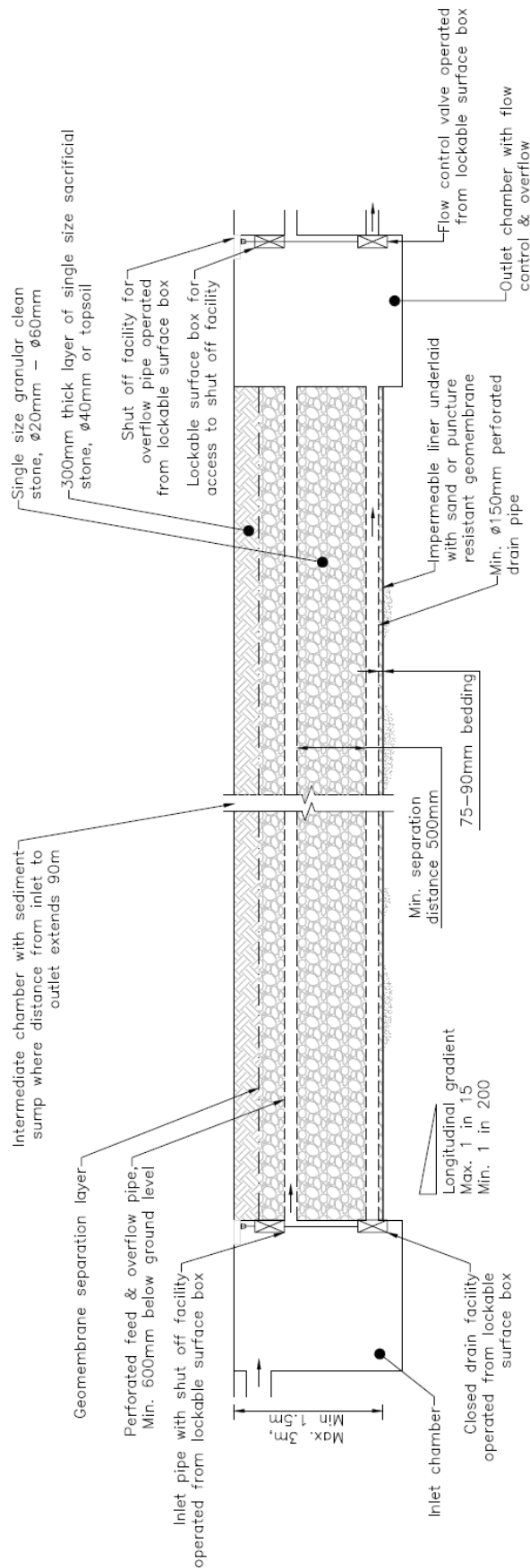
Not to Scale, dimensions in millimetres  
Full set and standard details, please contact Scottish Water

**FIGURE 14**  
**TYPICAL PIPED FILTER TRENCH CROSS-SECTION**



Not to Scale, dimensions in millimetres  
Full set and standard details, please contact Scottish Water

**FIGURE 15**  
**TYPICAL PIPE FILTER TRENCH LONG-SECTION**



Not to Scale, dimensions in millimetres  
 Full set and standard details, please contact Scottish Water

## **2.13 UNDERGROUND STORAGE**

### **2.13.1 General**

1. The use of underground storage (which provides no surface water treatment) shall only be allowed by specific agreement with Scottish Water. Where attenuation is required in excess of a 1-in-30 year storm event (including the allowances for urban creep and climate change) by the Local Authority, additional underground storage or attenuation shall not be permitted. Any additional storage shall be within low amenity open spaces and above ground level.

2. The design of any underground storage shall:

- provide access to allow inspection and maintenance
- allow CCTV and Jetting operations
- be suitably attenuated to ensure that there is no detrimental effect on the operation / frequency of any downstream assets
- be protected from silt and sediments through the installation of a suitable screen / silt trap device with the aim to minimise sedimentation (and, therefore, maintenance)
- oversized storage pipes used for storage, > 600mm dia, shall be Concrete, Structurally reinforced Polyethylene or Engineered Thermoplastic in accordance with Part 4 of this Specification..
- the use of geocellular storage units shall only be in non-trafficked areas (i.e. public open space)

3. Larger underground storage structures shall permit man-entry to enable inspection and maintenance activities to be carried out within the storage chambers and any manifold arrangements. This shall include suitable clear opening for safe access/egress. Covers shall be large enough to allow man-entry with breathing apparatus. Smaller underground storage structures shall have suitable access points to permit remote cleaning and inspection to be readily carried out.

4. Design options that shall be acceptable for vesting include pre-fabricated structures, oversized pipes or cast in-situ concrete structures.

5. The maximum water level in any underground storage structure shall be at least 500 mm below the lowest floor level of any adjacent premises.

### **2.13.2 Underground Storage – Configuration and Dimensions**

1. There is no constraint on size of structure that can be vested. The storage shall be sized in accordance with the hydraulic design requirements detailed in Sections 2.7 to 2.10 inclusive.

2. Access to underground storage structures shall normally be provided to enable man-entry through the underground storage from each end of the structure and, if it is longer than 50 m, then intermediate access points shall be provided. The minimum internal vertical dimension to permit man-access to the underground storage shall be determined by the design risk assessment.

3. Low-flow channels shall be provided in man-entry sized pipes.

4. The minimum gradient for storage systems shall be 1:100 for off-line tanks and 1:200 for on-line tanks to minimise sedimentation.

### **2.13.3 Underground Storage – Outlet Structure**

1. The outlet structure shall be designed to operate and discharge the design-limiting discharge rates. Appropriate hydraulic checks on the implications of high downstream water levels shall be made, where appropriate, and take account of the receiving watercourse or downstream sewer capacity. Orifice or vortex control units or similar may be used to control outflow rates.

2. Throttle controls shall be provided, in accordance with Part 4 (Civil Engineering Specification) fixed to the concrete outlet structure, allowing maximum opportunity for modification and refining the operation of the control system in the future. The minimum size of any orifice shall be 75 mm diameter.

3. A penstock to enable the drawdown of the storage unit shall be provided for maintenance and in case of blockage to the orifice control system. These shall be able to be operated safely from outside of the outlet structure.

4. The outlet structure shall have an overflow provided. In addition, an emergency overflow shall be provided as a separate structure but this shall not be constructed through an embankment. The flood flow from the emergency overflow shall be routed to avoid flooding of downstream properties.

#### **2.13.4 Underground Storage – Safety**

1. A design risk assessment shall cover all aspects of safety, including access, for maintenance and operation.

2. A minimum of two access points (upstream and downstream) shall be provided with maximum intervals between access points of 50 m.

3. Ventilation shall be provided to minimise the risk of build-up of dangerous gases.

#### **2.13.5 Underground Storage – Siting**

1. Underground storage shall be located beneath public areas or roads, with the exception of Geocellular storage units that shall only be located in non-trafficked areas (i.e. public open space)

### **2.14 SURFACE WATER SEWERS**

1. The drainage of privately-owned areas shall, preferably, be served by appropriate SUD systems prior to connection to the surface water sewerage to be vested.

2. Section 2.5 to 2.7 and Sections 2.13 to 2.18 also apply to the design and construction of surface water sewers.

### **2.15 PRIVATELY-OWNED PROPERTY DRAINAGE SYSTEMS CONNECTED TO PUBLIC SYSTEMS**

1. The hydraulic design criteria for private drainage are commonly set at the 1-in-10 year return period event. However, where overflows are deemed to be necessary from private property surface water drainage systems to the vested sewerage system, the design criteria shall be based on the 1-in-30 year critical duration event. Overflow connections shall only be acceptable where it can be demonstrated that they address a specific flood risk. Design calculations and arrangement details shall be provided to Scottish Water for approval. As part of the Vesting Agreement, source control details and drawings shall be provided in accordance with Section 2.4 of Part 2A.

2. The use of hydraulic throttle controls with diameters less than 30 mm are discouraged due to the risk of blockages occurring. Source controls shall mimic greenfield runoff rates in respect of the connected impermeable areas to vested surface water SUD systems and shall preclude interactions with non-statutory surface water land drains.

3. An additional 10% in the impermeable area shall be included to allow for a potential increase in runoff in the future (due to extensions or permeable surfaces being sealed, etc.).

4. Privately-owned property drainage shall avoid infiltration-based systems in areas where: there is a risk of mobilising polluted material; the depth to groundwater prevents an unsaturated zone of 1 m being provided; and soil permeability is less than  $1 \times 10^{-6}$  mm/per hour.

Note: Infiltration-based devices shall not be used to drain areas servicing vehicles where there are sensitive groundwater zones.

5. Property surface water drainage shall be connected to vested SUD systems via a connection chamber at each property boundary to allow visual inspection of the quantity and quality of the surface water discharges.

# SECTION 2C – SEWERAGE DESIGN

## 2.16 LAYOUT OF SEWERS AND MANHOLES

1. The layout of sewers and manholes shall be as simple as possible. Typical layouts and shown in Figure 16 and 17.
2. Where reasonably practicable, sewers shall be situated within areas maintained by the Local Authority, i.e., roads, verges and public open spaces. When located within the road, the sewer shall be at least 1 m from the kerbline and the outside of the manholes at least 0.5 m from the kerbline.
3. The layout shall be such that no public sewers are within private garden areas.
4. Where foul and surface water manholes are adjacent, positions shall be staggered to allow for crossing over of sewers.
5. Manholes and sewers shall be sited with due regard to existing and proposed public utility services. A manhole shall be built at every change of alignment, gradient or direction, at the head of all sewers, at every junction of two or more public sewers and wherever there is a change in the size of the sewer. Manholes shall not be further apart than 100 m.
6. To avoid conflict between connections on separate systems, sewers shall be constructed such that the minimum clearance between the connection and the higher/lower sewer shall be 150 mm. It is preferred that the foul sewer be below the surface water sewer. Separate sewers shall be a minimum of 300 mm apart with the surface water sewer being realigned locally at foul manhole positions. Foul and surface water manholes shall be staggered.
7. Bedding details and materials, and backfilling of pipelines shall be in accordance with Part 4 of this Specification. Unless otherwise agreed, Class B bedding shall be used for rigid pipes and Class S bedding for flexible pipes.
8. Any work proposed to be carried out within, or adjacent to, existing public sewers shall only be undertaken with the prior agreement of Scottish Water. Notice shall be taken of Scottish Water's health and safety procedures for working in public sewers.
9. Where there is risk of tree root intrusion, the sewer shall be resistant to tree root ingress (e.g., by use of appropriate barriers, high-performance joints or constructed from polyethylene with welded joints).
10. The design of landscaping shall be undertaken at the same time as the design of the drains and sewers so that the impact of tree roots on sewers and drains can be considered. A sewer shall not be located closer to trees/bushes/shrubs than the canopy width at mature height, except where special protection measures are provided, in accordance with Clause 2.14.9. A tree shall not be planted directly over sewers or where excavation onto the sewer would require removal of the tree. Restrictions on planting of new trees adjacent to sewers are to comply with Appendix XIII. The following shallow rooting shrubs are generally suitable for planting close to sewers and private drainage:

- *Berberis candidula* (Paleleaf barberry);
- *Berberis julianae* (Wintergreen barberry);
- *Ceanothus burkwoodii* (Californian lilac "Burkwoodii");
- *Cotoneaster dammeri* (Bearberry cotoneaster);
- *Cotoneaster skogholm* (*Cotoneaster x suecicus*, "Skogholm");
- *Cytisus varieties or Sarothamnus* ((Common or Scotch) broom);
- *Euonymus japonicus* (Japanese spindle);
- *Euonymus radicans* Variety of *Euonymus* (Fortune's spindle or wintercreeper);
- *Mahonia varieties* can be included in the genus *Berberis*. The most common name is *M. aquifolium* (Oregon grape);
- *Potentilla varieties*. Most varieties are types of cinquefoil. Also includes Common tormentil, silverweed and barren strawberry;
- *Skimmia japonica* (Skimmia);
- *Spiraea japonica* (Japanese spirea or Japanese meadowsweet);
- *Veronica varieties* (Speedwell);
- *Viburnum davidii* (David viburnum);
- *Viburnum tinus* (Lauristinus).

## 2.17 BUILDING OVER OR NEAR TO A SEWER

1. Under the terms of the Building Regulations 2004, (as amended) building over or near to a sewer shown on the statutory sewer map shall not normally be permitted. Where it is proposed to construct a building over the line of an existing sewer, the sewer may require to be diverted at the developer's expense. Where there is no other option, Scottish Water may permit buildings to be constructed over existing sewers. In such circumstances, the developer shall be required to take adequate measures to protect the sewer and an agreement between the developer and Scottish Water shall be necessary.

2. Sewers shall be located so that access may be obtained by a mechanical excavator, and this access shall generally be determined using Table 1, which shows minimum distances from the centre line of a sewer to the external face of any buildings/structures. These distances will be considered on a site-by-site basis. Where the requirements of Table 1 cannot be achieved Figure 18 may be considered with Scottish Waters approval.



**Table 1 Minimum Distances of Sewers from Buildings/Structures**

Sewer* Diameter / Size (mm)	Less than 150	150-299	300-449	450-600	601-749	750-924	925-1000	1001-1124	1125-1399	1400 or greater	For Box Culverts, the greater of;
Depth to Invert of Sewer (m)											
Less than 3.0	3.0***	3.0***	3.0	3.5	3.5	4.0	5.0	5.0	5.0	5.0	4.0 m from centreline or 2.0 m from the outside edge
3.0 to 4.0	3.0	3.0	3.0	4.0	4.0	5.0	5.0	5.0	5.0	5.0	5.0 m from centreline or 2.0 m from the outside edge
4.0 to 5.0	4.0	4.0	4.0	5.0	5.0	5.0	6.0	6.0	6.5	6.5	6.0 m from centreline or 2.5 m from the outside edge
5.0 to 6.0	5.0	5.0	5.0	6.0	6.0	6.5	6.5	6.5	6.5	6.5	6.0 m from centreline or 2.5 m from the outside edge
6.0 to 7.5	6.0	6.0	6.0	6.0	6.0	6.5	6.5	6.5	6.5	6.5	6.0 m from centreline or 2.5m from the outside edge
7.5 or greater**	4.0	4.0	4.0	4.0	4.0	5.0	5.0	5.0	5.0	6.0	6.0 m from centreline or 2.5 m from the outside edge
<b>Notes:</b>	This table does not apply to rising mains. * The term sewer includes disposal main. ** Repair, maintenance or renewal by open-cut methods is not anticipated. *** In certain instances, building over or close to an existing sewer may be controlled by Building Regulations. Developers shall consult Scottish Water on each situation.										

3. Sewers shall be located out with the zone of influence of any building. Where buildings are to be constructed immediately adjacent to sewers the building foundations shall be deepened, where necessary, to prevent loadings being transferred to the sewers.

4. The foundations of a building shall be taken down to such a depth, or be designed in such a way, that they do not place loading onto a sewer. Piled foundations, especially driven piles, shall require special consideration on a case-by-case basis. Developers considering piled foundations in the vicinity of sewers shall consult Scottish Water at the earliest opportunity.

5. The protected strip width for a particular sewer is normally twice the stand-off distance. For multiple sewers located together, the protected strip width shall be the total extent of the stand-off distances for the individual sewers.

## 2.18 CONNECTIONS

1. As far as possible on new sewers, branches for connections shall be built-in as the work proceeds to avoid the risk of damage to the sewer by installing connections at a later date.

2. Where connections are made to new sewers, the following criteria shall apply:

- a) connections shall be made using 45° angle or 90° curved square branches;
- b) saddle connections shall be permitted for sewers greater than 300 mm diameter but shall not be permitted where the diameter of the sewer is less than twice the diameter of the connection pipe;
- c) saddle connections shall not intrude into the sewer to ensure there is no detriment to the hydraulic operational performance.

3. Where connections are made to an existing sewer, the following criteria shall apply:

- a) connections into sewers of 300 mm diameter or less shall be made by inserting 45° angle or 90° curved square branches;
- b) angled saddle connections may be used on sewers greater than 300 mm diameter. Square saddles may be used on sewers of 900 mm diameter and above. Saddle connections shall not be permitted where the diameter of the sewer is less than twice the diameter of the connection pipe;
- c) saddle connections shall be made by trepanning a core out of the sewer pipe, at half barrel or higher, and mortaring in the saddle;
- d) branch connections shall be made by cutting the existing sewer, then inserting and jointing the branch using proprietary flexible couplings;
- e) branch or saddle connections shall not intrude into the sewer to ensure there is no detriment to the hydraulic operational performance;
- f) the saddle shall not protrude into the bore of the main sewer.

4. The designer shall be aware that particular conditions may be imposed by Scottish Water for connections to brick sewers, large diameter sewers or where adverse conditions make construction of a manhole difficult. This shall be taken into account when designing the system.

5. Property connections shall have a minimum diameter of 150 mm. Property connections of 300 mm diameter and above shall be made via a manhole.

6. Property connections shall be constructed at the same time as the main sewers. A disconnecting chamber shall be constructed on each connection and shall be located as near as possible to the curtilage boundary or heel of the footpath, and ideally in driveways. The connections shall be laid at a minimum gradient of 1:60 and a maximum of 1:10. The connection shall be plugged to prevent debris entering the sewer and clearly marked "FW" (foul water) or "SW" (surface water) until the houses are substantially complete.

7. Steep gradients for property connections shall be avoided.

8. Disconnecting chambers shall be clearly marked so that property drainage may be properly connected.

9. Marking shall take the form of a large "FW" or "SW" spray-painted on the inside of the disconnecting chamber and shall be clearly visible through the disconnecting chamber opening. Red shall be used for foul connections and blue for surface water connections.

10. Each property shall connect via one set of disconnecting chambers to the foul and surface water sewers, with the disconnecting chambers positioned to allow the connection to connect directly to the sewer as described in clause 2.18.2 with no bends.

11. In a flatted development, each block of flats associated with a stairwell shall normally connect via one set of disconnecting chambers to the foul and surface water sewers. The number of connections to the surface water sewer may be reduced should individual connections prove impractical due to the roof drainage design.

12. Where approval is given to connect a maximum of two adjacent properties via one set of disconnecting chambers to the foul and surface water sewers, this shall require the set of disconnecting chambers to be located as near as possible to the mutual boundary between the two

properties and the heel of the footpath, and the drainage for each property to be contained within the curtilage of that property. In such cases, the disconnecting chambers shall normally vest in Scottish Water and shall, therefore, be constructed in accordance with Figure 19 – 23 and the 'Standard Manhole Details' (SSP-SP-DRA-07000750).

## 2.19 EXISTING PUBLIC SEWER WITHIN THE SITE

1. As soon as a diversion of an existing public sewer is envisaged as part of the development, the developer shall contact Scottish Water to agree if the diversion is feasible and whether it can be carried out. Maximum use shall be made of roads and public open space and future access taken into consideration.

2. Where the developer wishes to abandon existing public sewers within their site, they shall contact Scottish Water to agree the required arrangement.

## 2.20 DESIGN OF MANHOLES

1. Figures 19 to 23 show typical details of manholes with depths from cover level to soffit of pipe not exceeding 6 m. No significant departure from these shall be made without the approval of Scottish Water. The use of Type D and F manholes will require the agreement of Scottish Water. Manholes shall be designed and constructed in accordance with BS EN 752. Alternative forms of manhole construction using precast bases have been approved for use and are detailed in Figures 15 and 16.

2. Manhole diameters (Type A and B only) shall be in accordance with Table 2:

**Table 2 Manhole Diameters**

<b>Diameter of Largest Pipe in Manhole (mm)</b>	<b>Internal Diameter of Manhole (mm)</b>
Less than 375	1200
375 – 450	1350
450 - 700	1500
750 - 1050	1800
1125 - 1500	2100
>1500	Consult Scottish Water

3. The height of a Type A manhole (benching to slab soffit) shall normally be in excess of 2000 mm. Where this is impracticable, Type B manholes are preferred subject to an absolute minimum height (benching to slab soffit) of 900 mm. The internal diameters quoted above are considered to be the minimum. Where two or more pipes enter the manhole, the internal diameter may have to be increased to accommodate the minimum width of benching. Pipes of different diameters entering manholes shall be installed with soffits at the same level.

4. Manhole covers and frames shall be in accordance with Section 4.2.30 of this Specification.

5. Rocker pipes shall be provided at entry to and exits from manholes. Their length shall be as shown in the Table in Section 4.6.6 of this Specification and as indicated in Figure 24.

6. Steeper gradients are preferred to the use of backdrops. Where backdrops are unavoidable, they shall be constructed as shown in Figure 25.

7. Where step rungs and ladders are to be used, top-step rungs are to be located not less than 500 mm and not greater than 700 mm from the finished manhole cover level. Table 3 shows minimum clear access opening sizes and fitting requirements for Scottish Water.

**Table 3 Minimum Clear Access Opening Sizes and Requirements for Fittings**

Standard Access (Sewer Diameter - mm) Manholes Type A & B only			Manhole Fitting Requirements - All Manhole Types			Non-man Entry Chambers
150-874	875-1074	1075 or greater	Double encapsulated step rungs	Safety chains (Materials)	Ladders (230 mm clearance wall to ladder)	For sewer manholes
675 x 675			Less than 6 m	600 mm or greater	Greater than 6 m	Not accepted

8. Buried manholes may be required where ploughing operations are likely to take place and shall be constructed in accordance with Scottish Water's requirements. They shall only be allowed where indicated on an approved layout/longitudinal section and shall be located using marker/indicator posts at boundary fences or similar positions, giving the distance to the buried manhole. Where Scottish Water has agreed for manholes to be buried, covers shall be set 600 mm below ground level and suitably covered and taped with waterproof material.

9. Monoblock "in-fill" type covers shall not be used. Where a cover is located in an area of block paving, the frame shall be 150 mm deep.

10. Frames for manhole covers shall be bedded in a polyester resin bedding mortar in all situations where covers are sited in NRSWA Road Categories I, II or III.

11. The first manhole upstream from the connection to the (existing) public surface water sewer shall, when constructed, be fitted with a 6 mm 2-dimensional screen in order to prevent debris entering the public sewer during the remaining construction works on site. The screen and/or silt trap shall be maintained by the developer and shall not be removed until immediately prior to adoption of the sewers by Scottish Water.

12. Suitably rated composite manhole covers may be used in non-trafficated areas to deter future theft.

13. Where alternative manhole construction is being used with a preformed manhole base, Fig 21 & 22, the minimum benching either side of the manhole channel shall be 300mm wide to allow safe egress into the preformed manhole benching. Traditional manhole base construction shall have a minimum of 500mm between the step rungs/ladder and the manhole channel, Fig 19 & 20.

## **2.21 DEPTHS OF SEWERS**

1. Sewers laid within roads shall have a minimum cover of 1.5 m measured from the top of the pipe barrel to the finished road surface, in order to avoid interference with other underground utility pipes and cables. Where this is not practicable, special protective measures may be required (see 4.5.3 in the Civil Engineering Specification). The design of the pipeline shall take account of loading from the passage of the developer's construction plant as well as normal design loading.

2. Sewers not laid in the road shall be laid at a sufficient depth to avoid interference with land drains or cultivation. Cover over the shallowest part of the pipeline structure of 0.9 m would normally satisfy this requirement.

3. Where the above minimum depths cannot be achieved, consistent with good hydraulic design, rigid pipes shall be protected by a full concrete surround. While the minimum depth for sewer has been increased to 1.5 m, full concrete surround will only be required where pipes are at a depth of less than 1.2 m. Similarly, flexible pipes shall be protected by a concrete slab spanning the pipe trench. Ductile iron pipes between manholes may be considered as an alternative solution to this problem where no connections are required.

## 2.22 MINIMUM SEWER SIZE AND PIPE MATERIALS

1. The minimum size of a gravity sewer is to be 150 mm nominal internal diameter.
2. Vitrified clay, Ductile Iron, Concrete, uPVC and Thermoplastic wall pipe materials shall be in accordance with Part 4 of this Specification and the following statements:
  - a) Thermoplastic structured wall pipe can be used up to a maximum diameter of 600mm for adoptable foul, surface water and combined sewers and be terracotta in colour. The use of any diameters above 600mm will require the approval of SW via a waiver submission accompanied with structural calculations.
  - b) Smooth walled uPVC pipe can be used up to a maximum diameter of 500mm for adoptable foul, surface water and combined sewers and be terracotta in colour. The use of any diameters above 500mm will require the approval of SW via a waiver accompanied with structural calculations.
  - c) Structured wall plastics and uPVC pipe shall only be permitted for commercial and industrial site drainage where Scottish Water is satisfied that the effluent shall not adversely affect the structural integrity of the pipe.
  - d) All PVC and Structured walled pipes shall be rated to withstand standard jetting pressures as described in WIS 4-35-01.
3. The use of large diameter pipework, greater than 600mm diameter for the storage or the conveyance of sewerage (foul, Surface Water and Combined) shall be Concrete, Structurally Reinforced Polyethylene (SRP) or Engineered Thermoplastic in accordance with Part 4 of this Specification.
4. The use of manufactured and integrated Manholes on pipework > 1200mm dia. may be used to provide access in accordance with Appendix XI and XII with the approval of Scottish Water.

## 2.23 HYDRAULIC DESIGN - FOUL SEWERS

1. Flows from proposed developments shall be calculated using the following criteria. These criteria include an allowance for infiltration.
  - a) Housing - The design flows for foul gravity sewers for residential developments shall use a peak flow rate of 4300 litres per unit dwelling per 24 hours (0.05 litres per second per dwelling unit).
  - b) Industrial -
    - i. Domestic flow shall be calculated in accordance with BS EN 752 using the discharge unit method in BS EN 12056-2 system type III or, in the absence of appropriate detail, 0.6 litres per second per hectare of developable land;
    - ii. Trade effluent flow shall be based on a metered water supply from a premises similar to that proposed, or shall assume 0.5 litres per second per hectare for normal industry and 1 litre per second per hectare for wet industry. Where the proportion of wet industry is unknown, use an average flow of 0.75 litres per second per hectare.

Note: For industrial premises, the domestic flow shall be added to the trade effluent to give the total design flow.

2. To provide a self-cleansing regime within foul gravity sewers, the minimum flow velocity shall normally be 0.75 metres per second at one-third design flow. Where this requirement cannot be met, then this criterion would be considered to be satisfied by a 150 mm nominal internal diameter gravity sewer having a gradient not flatter than the following:

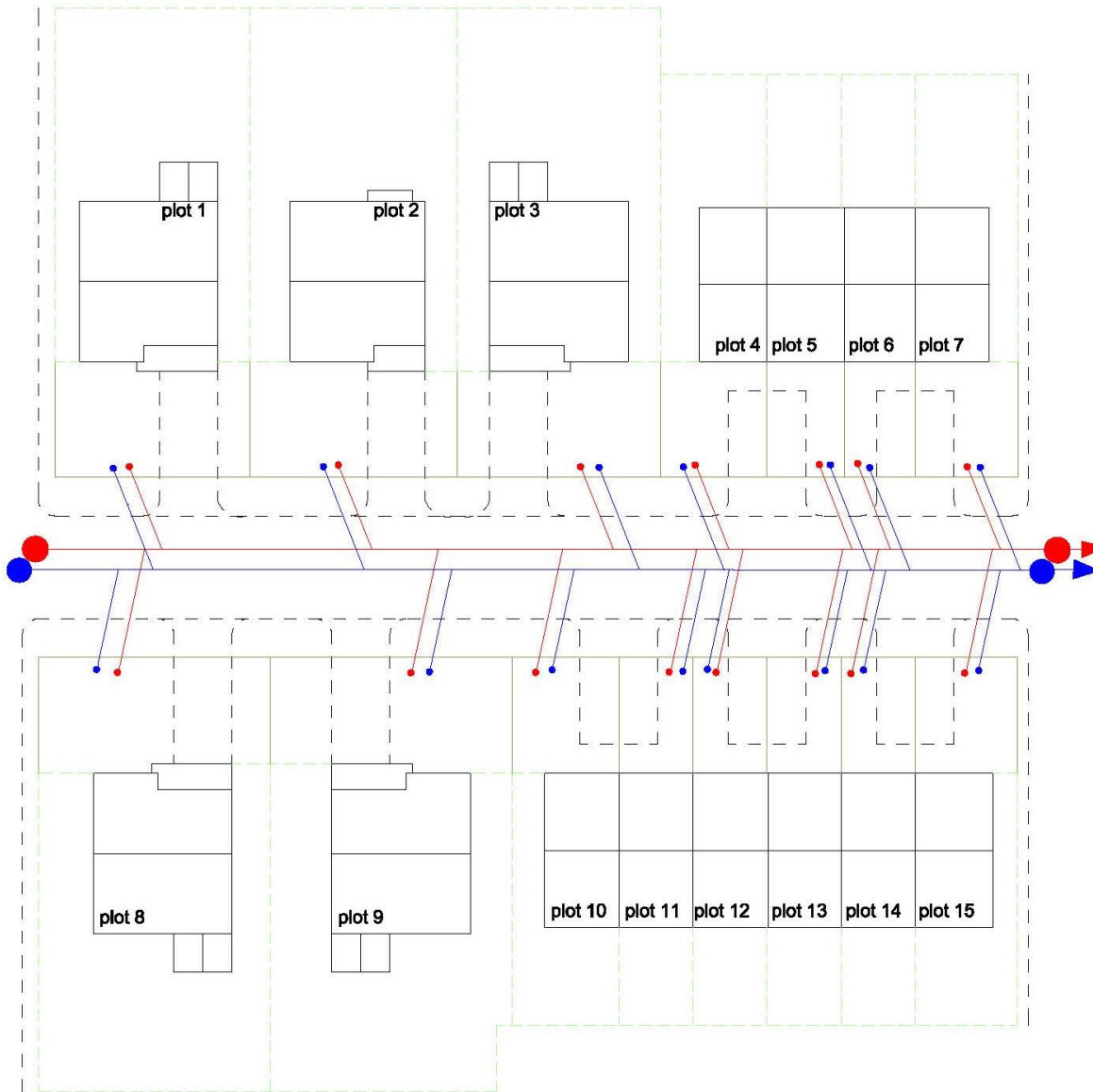
- a) 1 in 150 where there are at least ten connected dwelling units;
- b) 1 in 60 for up to nine connected dwelling units.

Note: These parameters are not to be taken as a norm when the topography permits steeper gradients. Hydraulic studies indicate that these requirements may not necessarily achieve a self-cleansing regime. When a choice has to be made between gravity sewerage and pumped sewerage, these criteria shall not be regarded as inflexible.

3. The roughness value ( $k_s$ ) for foul gravity sewer design shall be 1.5 mm.

Note: There is no set maximum velocity and, therefore, no set maximum gradient, but measures may be required in respect of energy dissipation and safety. If gradients steeper than 1 in 10 are unavoidable, special bedding arrangements may be required.

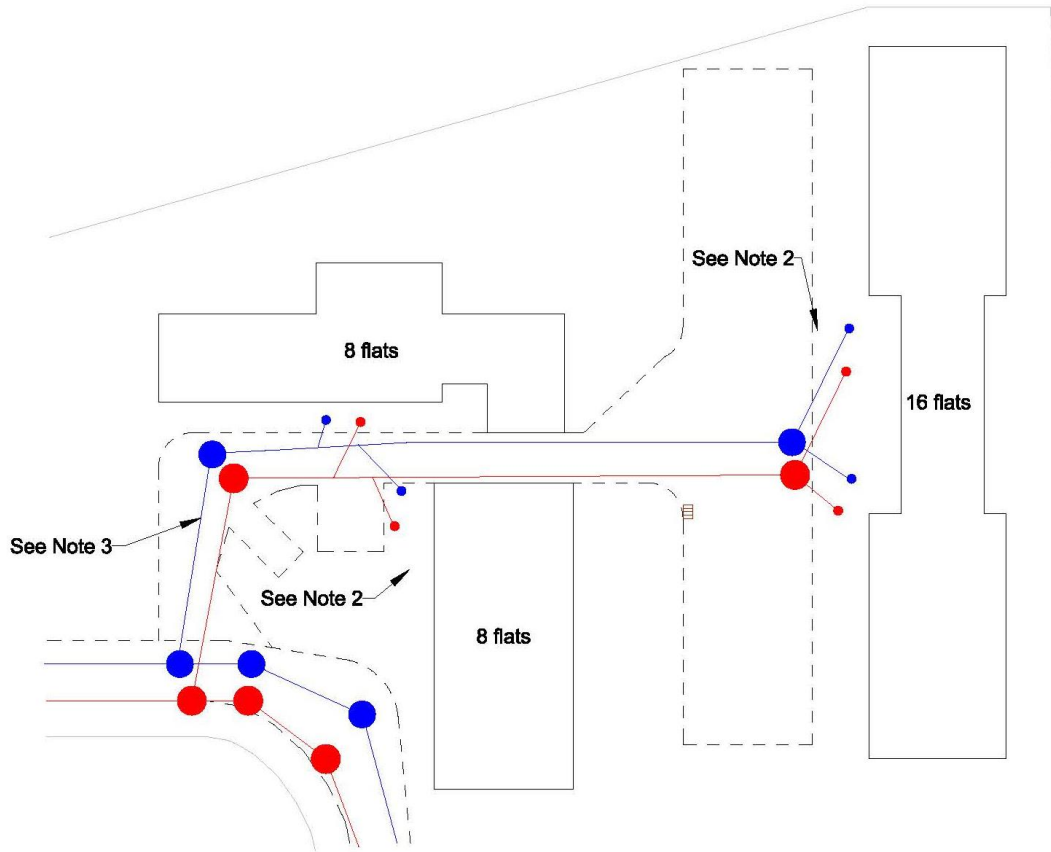
**FIGURE 16  
TYPICAL SEWERAGE LAYOUT 1**



- Key:**
- Surface water sewer
  - Surface water manhole
  - Surface water disconnecting chamber
  - Foul water sewer
  - Foul water manhole
  - Foul water disconnecting chamber
  - Unfenced or low fence boundary
  - High fence boundary

Not to Scale, dimensions in millimetres  
Full set and standard details, please contact Scottish Water

**FIGURE 17  
TYPICAL SEWERAGE LAYOUT 2**



Designation of individual pipes will depend on curtilage. See Glossary

**Key:**



Surface water sewer  
Surface water manhole  
Surface water disconnection chamber

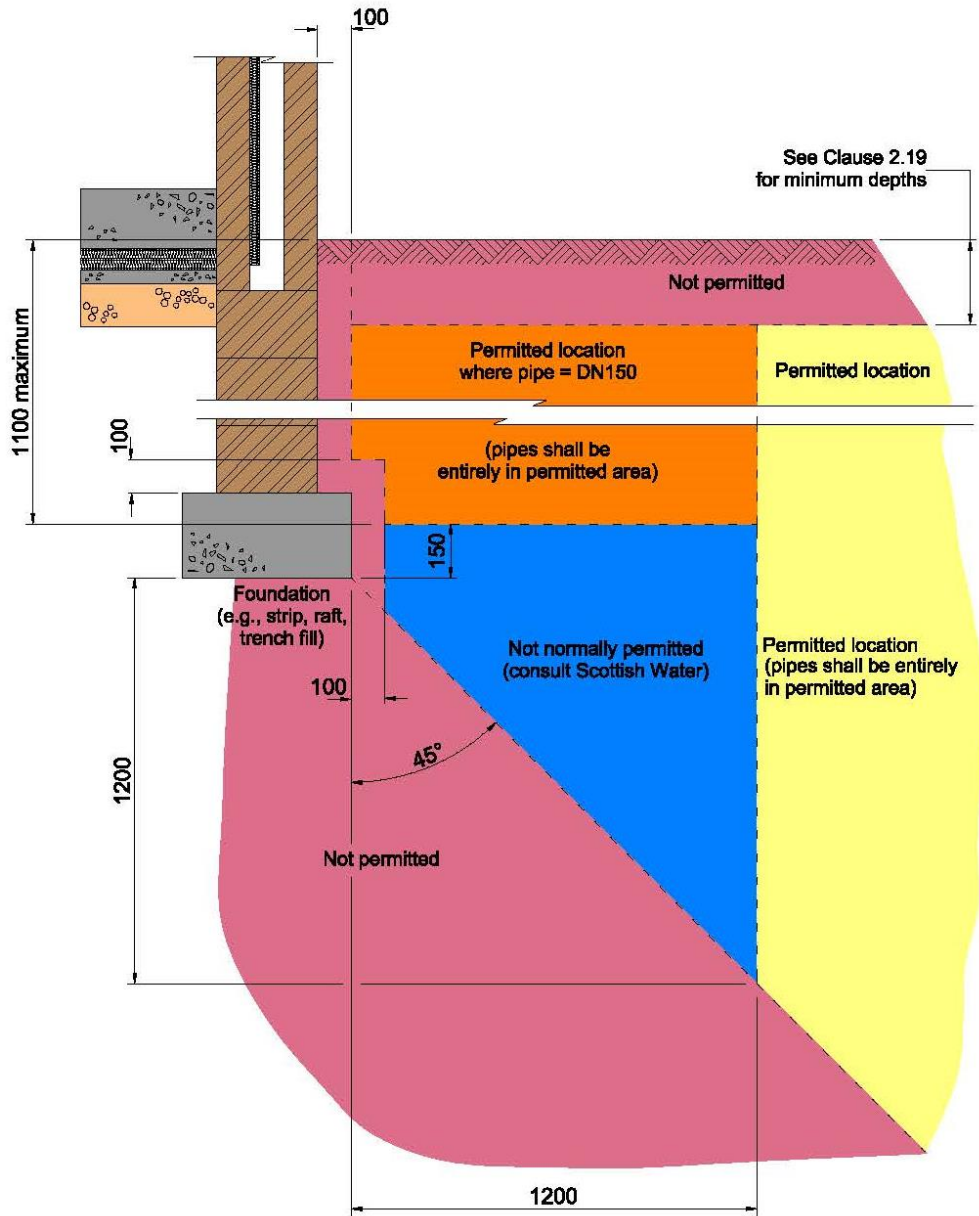


Surface water sewer  
Foul water manhole  
Foul water disconnection chamber

Not to Scale, dimensions in millimetres  
Full set and standard details, please contact Scottish Water



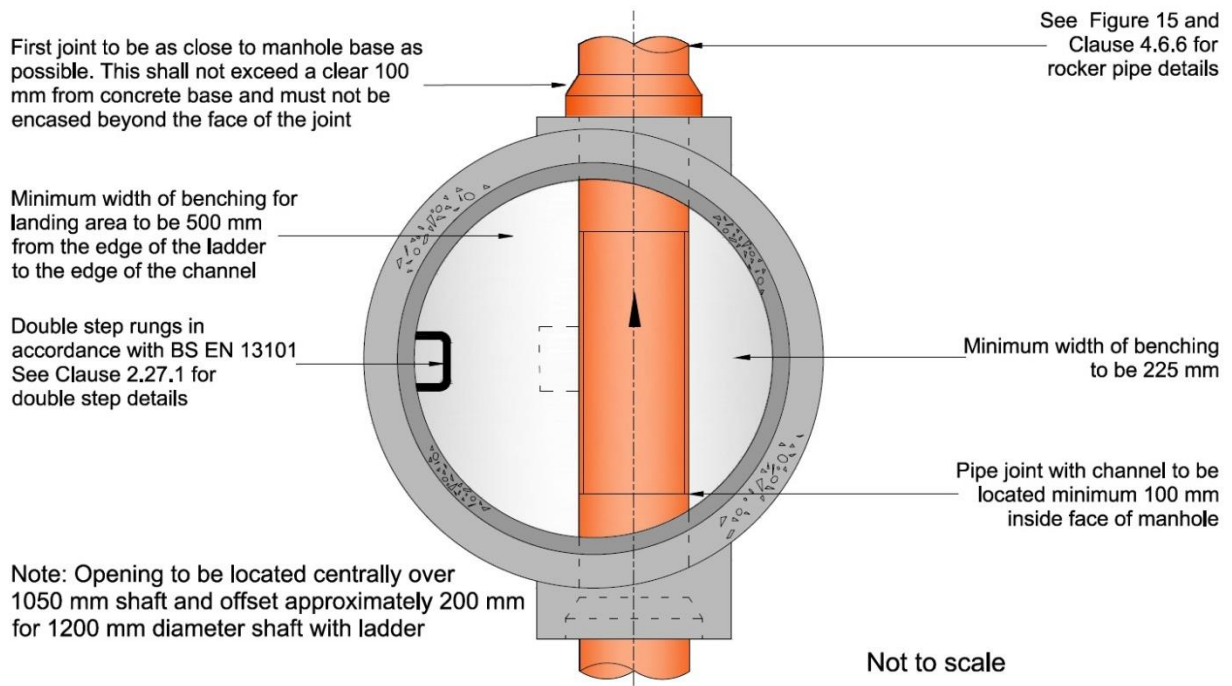
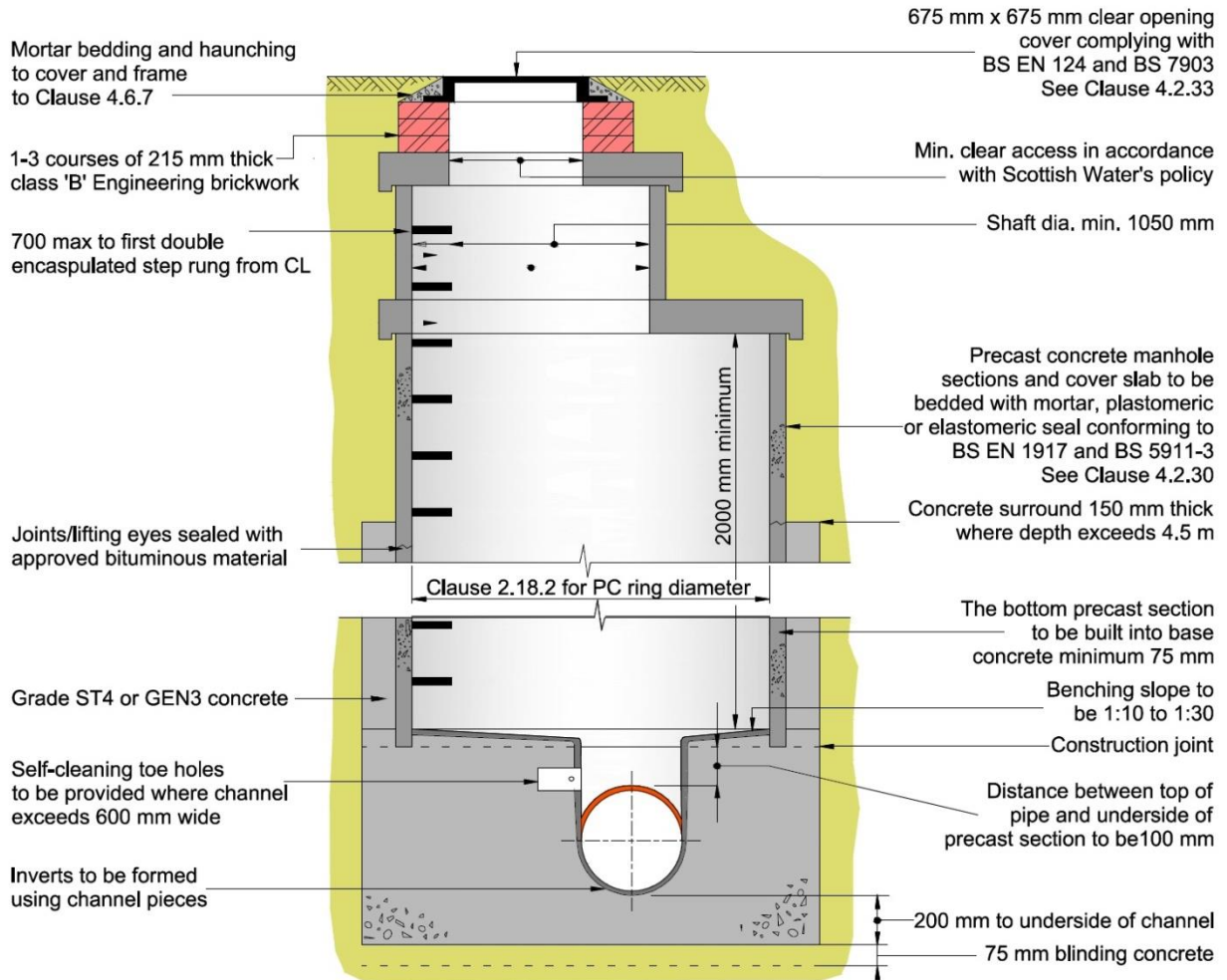
**FIGURE 18  
PERMITTED LOCATION OF SEWERS**



Not to Scale, dimensions in millimetres  
Full set and standard details, please contact Scottish Water

**FIGURE 19**  
**TYPICAL MANHOLE DETAIL – TYPE A (Traditional Base)**

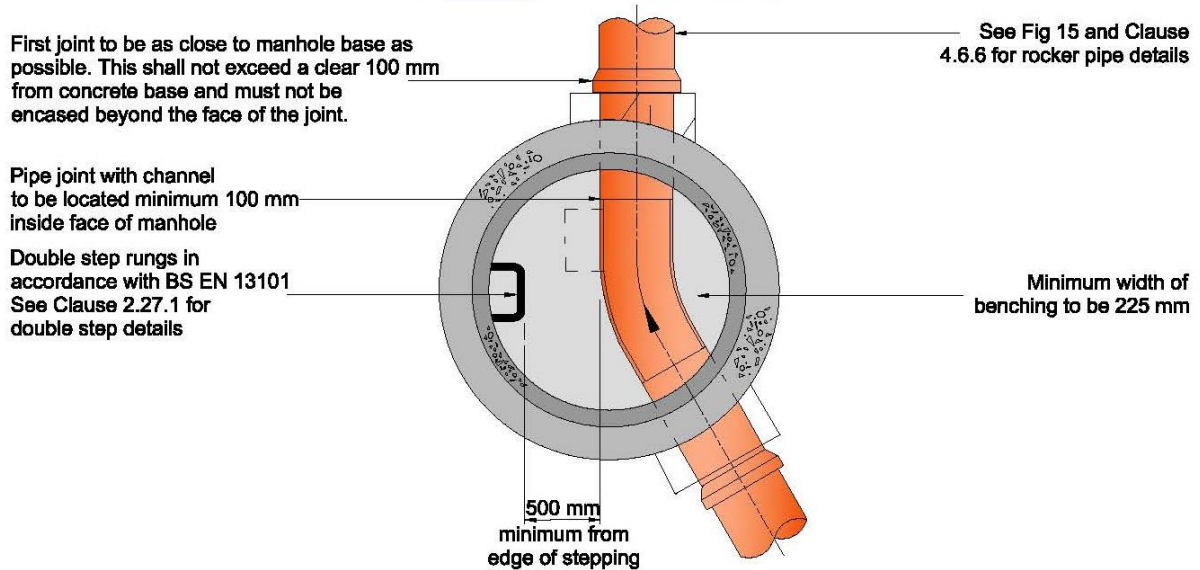
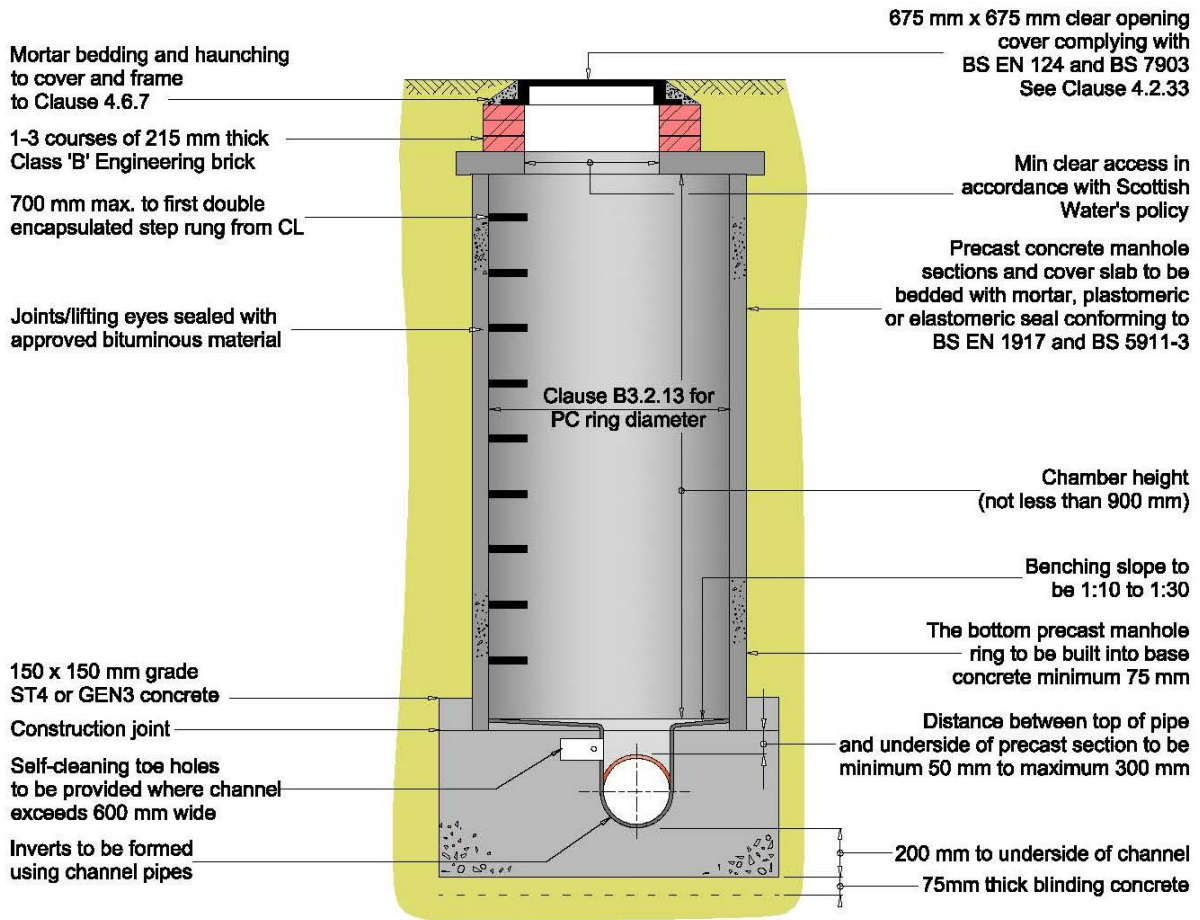
Depth from cover level to soffit of pipe 3 m to 6 m



Not to Scale, dimensions in millimetres  
 Full set and standard details, please contact Scottish Water

**FIGURE 20**  
**TYPICAL MANHOLE DETAIL – TYPE B (Traditional Base)**

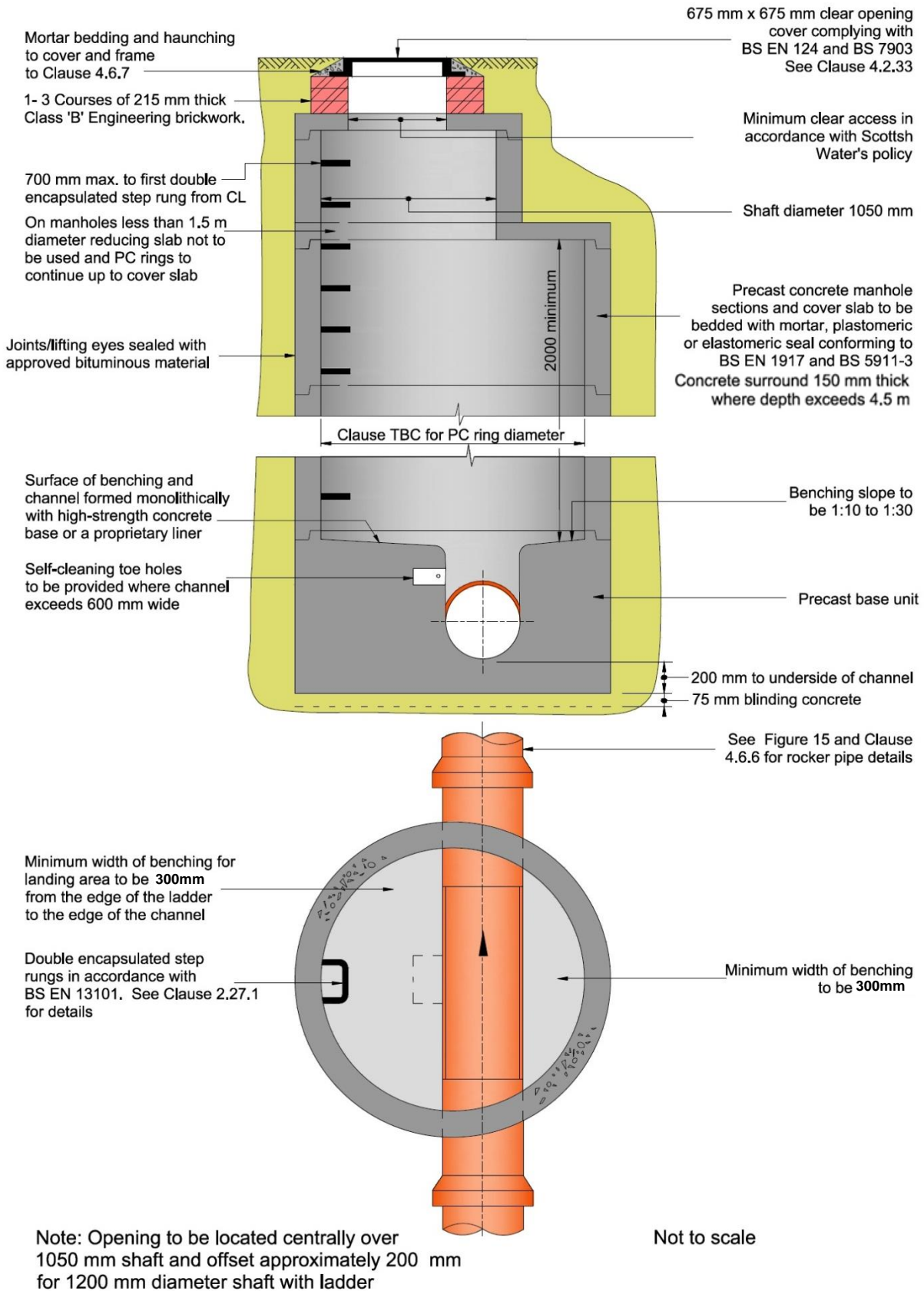
Maximum depth from cover level to soffit of pipe 3.0 m



Not to Scale, dimensions in millimetres  
 Full set and standard details, please contact Scottish Water

**FIGURE 21**  
**TYPICAL MANHOLE DETAIL – TYPE A1 (Pre-Cast Base)**

Depth from cover level to soffit of pipe 3 m to 6 m

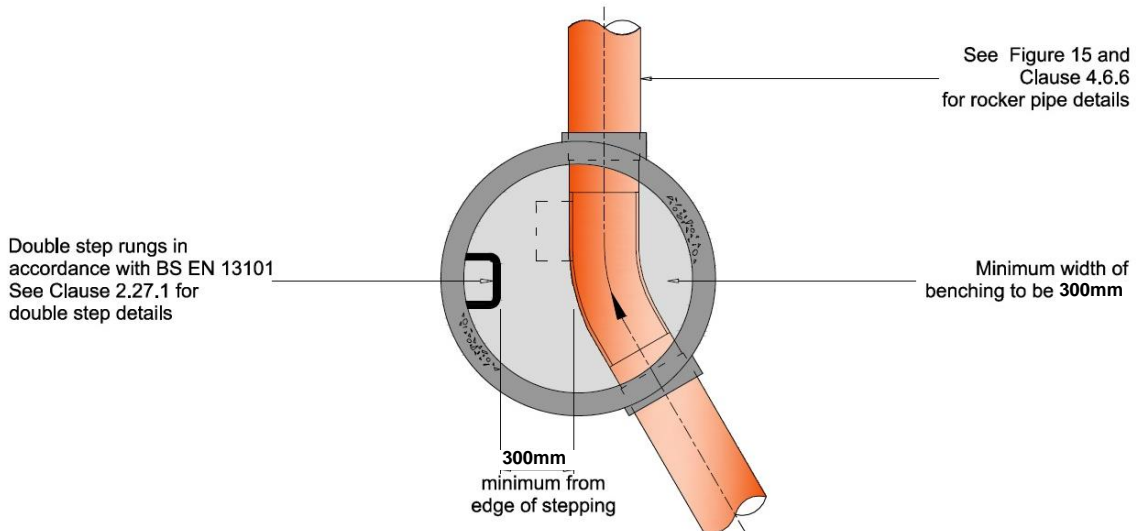
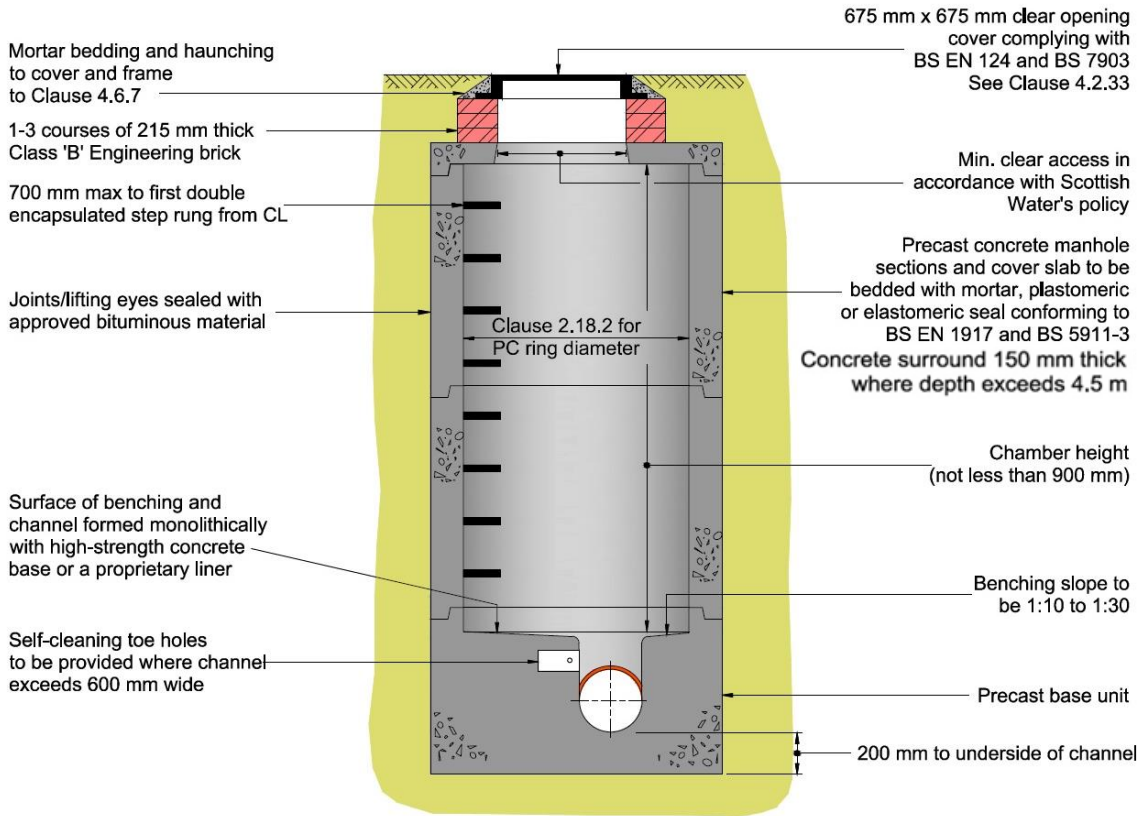


Not to Scale, dimensions in millimetres  
Full set and standard details, please contact Scottish Water



**FIGURE 22**  
**TYPICAL MANHOLE DETAIL – TYPE B1 (Pre-Cast Base)**

Maximum depth from cover level to soffit of pipe 3.0 m

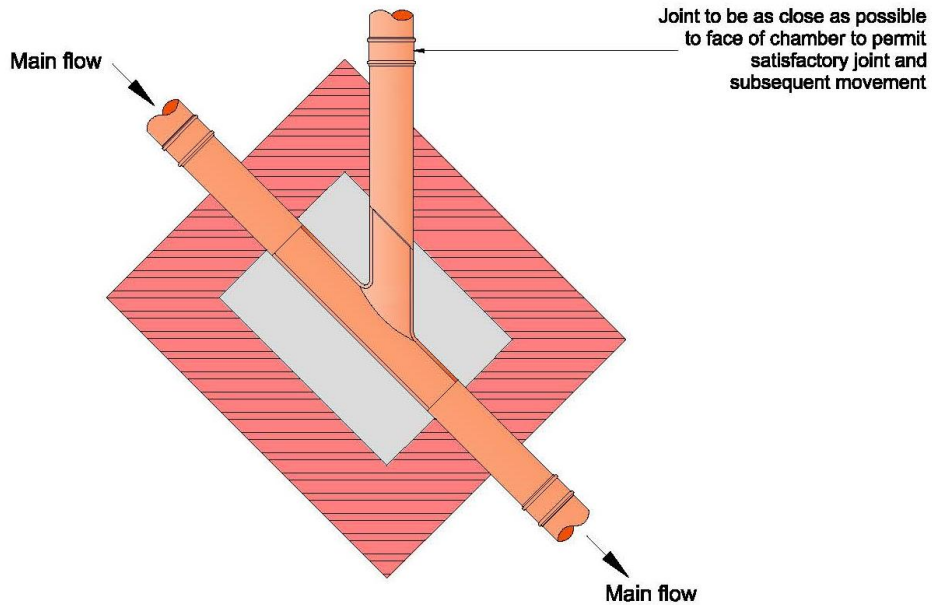
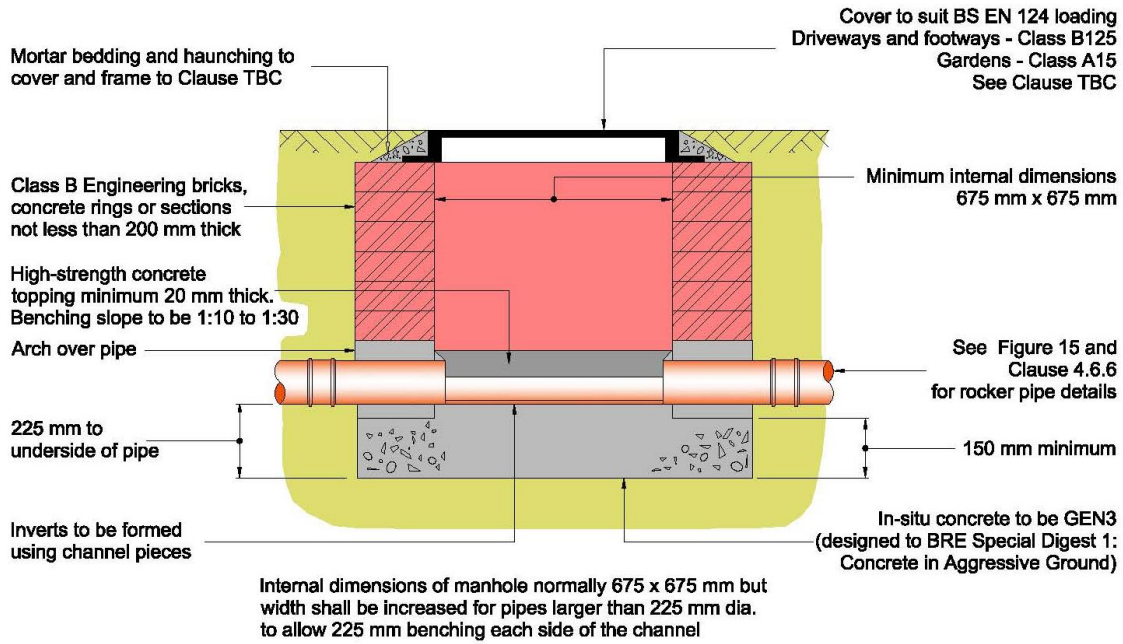


Note: Opening to be located centrally over 1050 mm shaft and offset approximately 200 mm for 1200 mm diameter shaft with ladder

Not to Scale, dimensions in millimetres  
 Full set and standard details, please contact Scottish Water

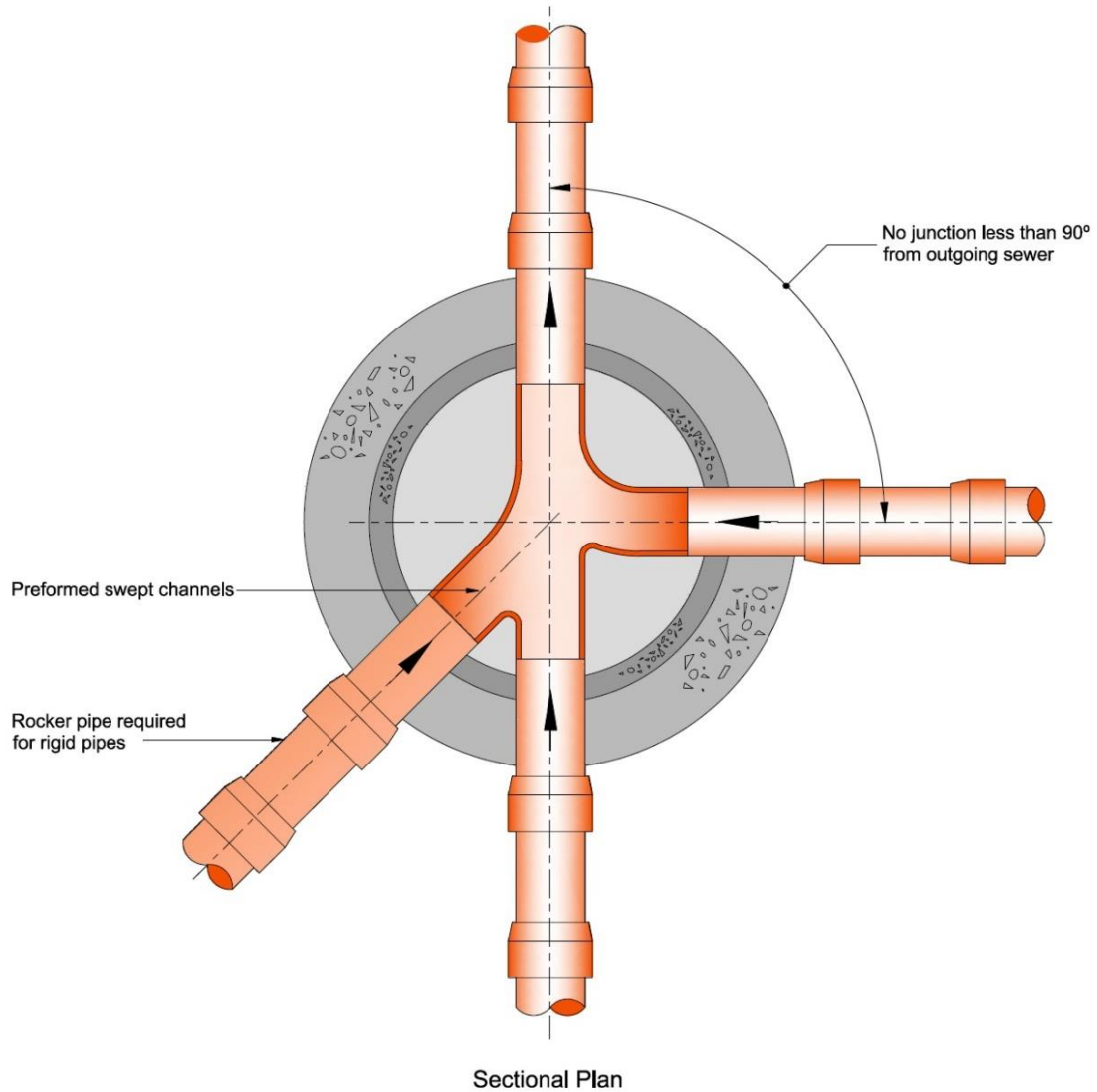
**FIGURE 23  
TYPICAL MANHOLE DETAIL – TYPE C**

Maximum depth from cover level to soffit of pipe 1.5m



Not to Scale, dimensions in millimetres  
Full set and standard details, please contact Scottish Water

**FIGURE 24**  
**TYPICAL MANHOLE ARRANGEMENT OF PIPE JUNCTIONS**



Rigid pipes built into manholes shall have a flexible joint as close as feasible to the external face of the structure and the length of the next rocker pipe shall be as shown

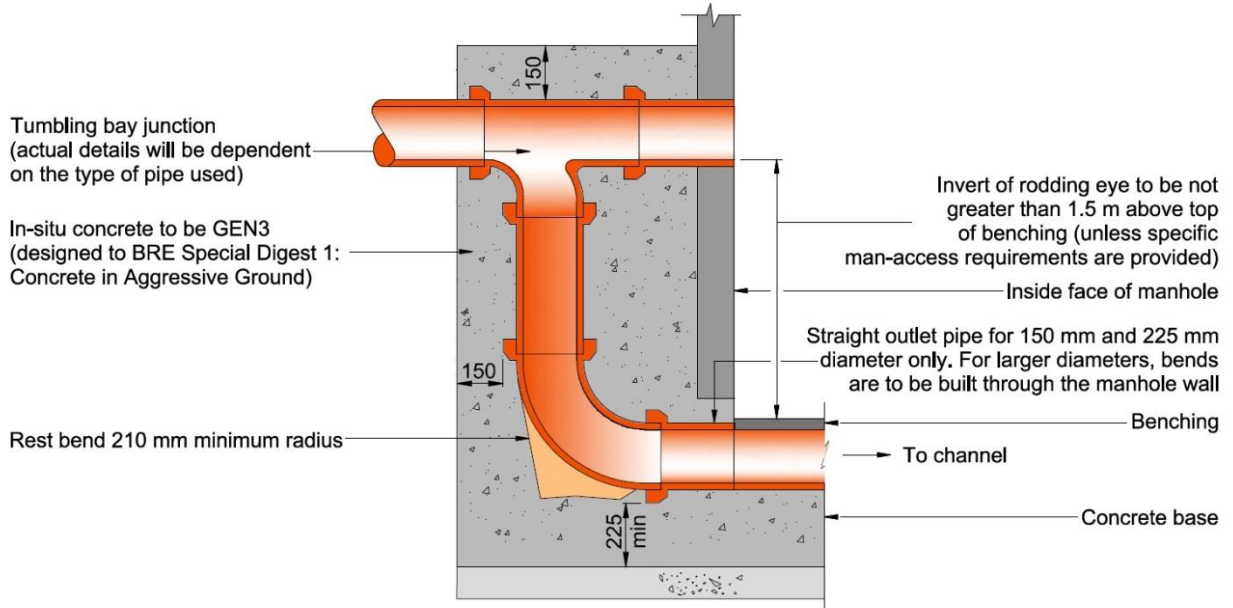
Nominal diameter (mm)	Maximum effective length (m)
150 - 600	0.6
601 - 750	1.00
over 750	1.25

All pipes entering the bottom of the manhole to have soffits level

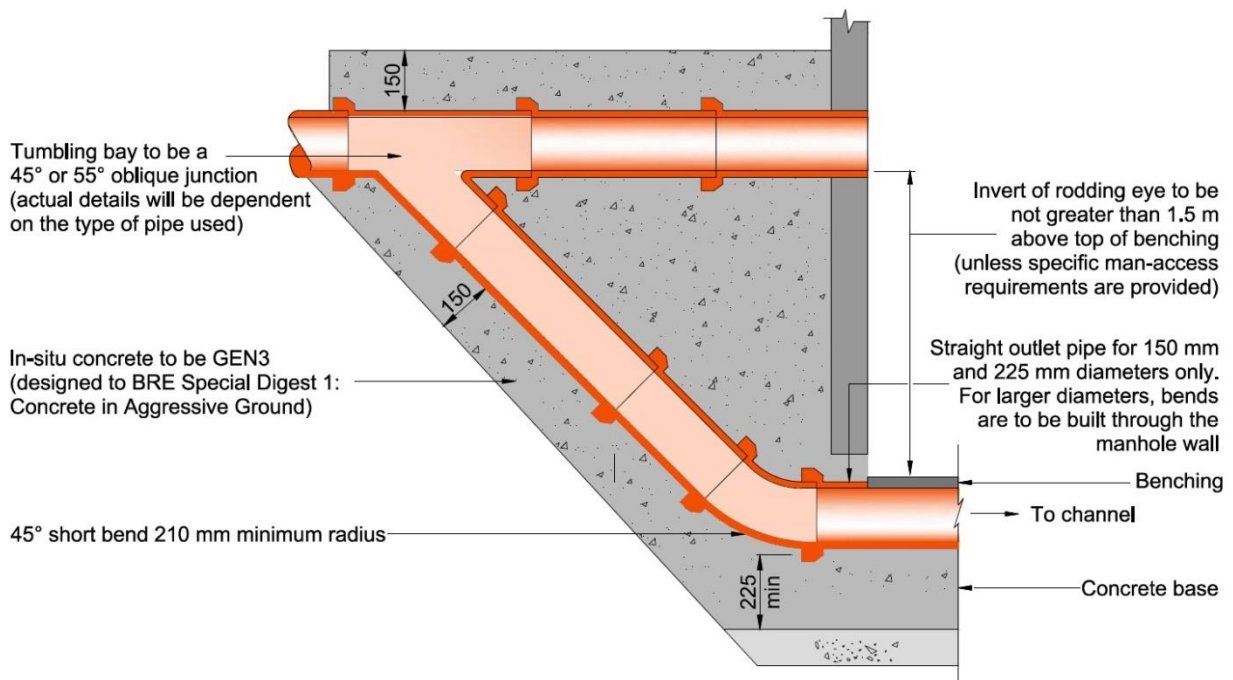
Not to Scale, dimensions in millimetres  
 Full set and standard details, please contact Scottish Water

**FIGURE 25**  
**TYPICAL VERTICAL AND RAMPED BACKDROP**

Note: Steeper gradients are preferred to the use of backdrops.



**External Vertical Backdrop**



**External Ramped Backdrop**

Not to Scale, dimensions in millimetres  
 Full set and standard details, please contact Scottish Water



# SECTION 2D – PUMPING

## STATION DESIGN

### 2.24 INTRODUCTION

1. Foul sewage pumping stations or pumped systems shall only be used where the life cycle cost calculated over a period of 40 years is less than conventional gravity systems over the same period. This shall include all civil and mechanical/electrical works for each option.

2. Where a pumping station is the lowest life cycle cost option the design of the wastewater pumping station shall comply with one of the following alternative approaches to meet the requirements of Scottish Water:

- a. Scottish Water Standard Product Pumping Station: a package pumping station, factory assembled, tested and available for site installation in accordance with the 'Scottish Water Standard Product Catalogue'.
- b. Bespoke Pumping Station Design: a bespoke pumping station design in accordance with Sewers for Scotland 4<sup>th</sup> Edition.

3. Pumping stations shall be classified by incoming peak design flow:

- a. Type 1 - having an incoming peak design flow of  $\leq 0.25$  litres per second (typically five dwellings or less);
- b. Type 2 - having an incoming peak design flow of  $> 0.25$  litres per second but less than 1 litre per second (typically six to twenty dwellings);
- c. Type 3 - having an incoming peak design flow of  $\geq 1$  litre per second (typically more than twenty dwellings) but with per pump rated no more than 22 kW each (for 100 A supply).

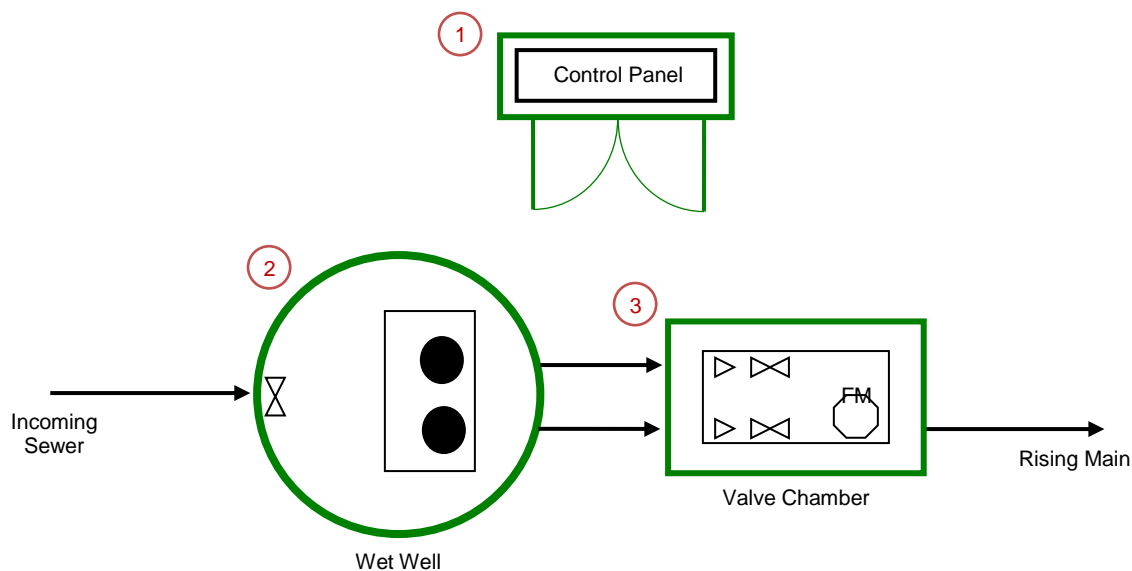
The classification shall affect various design requirements and parameters as specified in Sewers for Scotland.

#### 2.24.1 Scottish Water Standard Product Pumping Station

1. The pumping station shall comprise Scottish Water Framework components and be transported to site in a series of integrated sub-assemblies comprising:

- (1) Motor control centre (MCC) and GRP kiosk;
- (2) Wet well and associated pumps, pipework, covers, etc.;
- (3) Valve chamber and associated pipework, valves, covers, etc.;

**Figure 26 Schematic Layout of a Package Pumping Station**



2. The actual site requirements for these sub-assemblies will be specified within:

- Wet well - Pumping Station Standard Product Datasheet;
- Valve chamber - Pumping Station Standard Product Datasheet;
- MCC and kiosk - MCC Product Catalogue Datasheet;

and will be completed by the Designer.

### **2.24.2 Bespoke Pumping Station Design**

1. Where the Designer provides a bespoke pumping station it must be compliant with all relevant sections of Sewers for Scotland and in particular with Section 2D.2. Section 2D incorporates industry recommendations for the design and construction of new pumping stations and pumping mains. Some requirements for pumping mains are similar to those for foul sewers and drains: in these cases reference is made to Section 2B.

3. Section 2D covers submersible pumping stations not exceeding 22 kW per pump unit and where the maximum depth of the wet well from ground level to the underside of the pump unit is 6 m.

4. Where the pumping station will exceed 22 kW per pump unit or the depth exceeds 6 m, the developer shall consult Scottish Water for detailed requirements.

5. Foul pumping stations serving a single property shall not be vested in Scottish Water.

### **2.24.3 Life Cycle Cost**

1. All pump selections and proposed operating regimes shall be supported by a life cycle cost (LCC) analysis. This shall be issued to Scottish Water as part of the design submission.

2. The overall pumping system design shall ensure the combined selection of pumping main diameter, station pipework and pumping plant that represents the lowest LCC option for each application whilst considering all fundamental characteristics essential to good design practice, e.g., pumping main velocity, pumping main retention time, pumps solids handling ability, etc.

3. Sewers for Scotland 4<sup>th</sup> Edition reflects the requirements necessary to create an ideal pumping system however Scottish Water recognises that in many cases it will not be possible to comply with all the specified parameters. Any proposed deviation from the Sewers for Scotland 4<sup>th</sup> Edition Specification shall be submitted to Scottish Water in the form of a Waiver Request at the design

stage of the development. The Waiver Request shall be accompanied by a completed LCC analysis and full pump and system curves for all options considered to allow Scottish Water to assess the proposal fully.

4. Life cycle costs for mechanical and electrical equipment shall be evaluated over a 20-year period.

5. A standard LCC model is available from Scottish Water. Alternatively, developers may utilise the WIMES life cycle cost (LCC) model available online from the Pump Centre.

#### **2.24.4 Drainage Impact Assessment**

1. The pumping main point of discharge to the downstream sewer shall have no adverse effect on the system under all weather or tidal conditions. A drainage impact assessment (DIA) shall be carried out to demonstrate the satisfactory operation of the proposed pumping station under all conditions.

2. The DIA shall be carried out using pumped flowrates and estimated discharge frequencies for the proposed design. Average pumping station inflow rates from the upstream system shall not be used for the DIA if a pumping station is to be constructed.

3. If the pump selection changes throughout the design the DIA must be updated and any impacts taken into account.

4. If the development is to be phased, the DIA must account for the pumped flows from the final pump selection that serves the full development i.e. the highest pass forward flow from the pumping station.

#### **2.25 GENERAL**

1. The pumping station shall be fully automatic with remote monitoring by telemetry.

2. Plant and equipment shall be reliable, efficient and capable of operating without a high level of attention or inspection. Annual inspections only are normally required.

3. The developer shall ensure that both the electricity supply and telecommunication connection are provided by suppliers approved by Scottish Water and are transferred to Scottish Water at the time of vesting.

4. Arrangements for testing and vesting of the completed installation shall be approved by Scottish Water. The vesting process for M&E elements of pumping stations is available from Scottish Water.

5. A pumping station which is an accessory belonging to a sewer shall be shown on the plan for the laying of the sewer attached to Notice under Section 3A of the Sewerage (Scotland) Act 1968. Where such a Notice is not served, the pumping station shall be shown on the plan attached to a Deed of Servitude approved by Scottish Water. In all other cases, the land shall be acquired on behalf of Scottish Water. The access to a pumping station shall be agreed with Scottish Water.

6. To ensure that sewage flooding does not occur at, or upstream of, the pumping station during plant or power failure, additional storage shall be provided. This storage shall be above the high-level alarm and below the lowest invert of a connected disconnection manhole. As a minimum, the storage shall equate to 160 litres per dwelling. The developer shall identify and agree with Scottish Water and SEPA the first point of exit of sewage from the system following pumping station failure.

Note: Storage capacity in the sewers and manholes may be utilised and calculations and associated drainage long sections shall be provided.

7. For all phased developments, special measures may be necessary such as chemical dosing, twin rising mains and / or VSD's in order to minimise the impact of low inflows to the pump station during

early phases of the development. These measures shall be discussed and agreed with Scottish Water.

8. The developer shall take account of the timescale required to finalise land acquisition and gain SEPA, or other relevant authority, consent for any pumping station overflow discharge. Discussions on approval or consent shall be undertaken through Scottish Water and any consent issued by SEPA shall be transferred to Scottish Water at the time of vesting.

### **2.25.1 Operation and Maintenance Manual**

1. A standard template for a Waste Water Pumping Station Operation and Maintenance Manual is available from Scottish Water
2. The Developer shall utilize the Standard Template to provide a site specific Operation and Maintenance manual for each pumping station
3. Guidance on how to complete and submit the Operation and Maintenance Manual is included within the standard template.
4. The developer shall submit the Operation and Maintenance Manual in both abbreviated paper and electronic formats to Scottish Water for approval.

## **2.26 PROVISION OF PUMPING STATIONS**

### **2.26.1 Location**

1. The minimum distance from the wet well hard standing of the pumping station to any habitable buildings shall be in accordance with Table 4, in order to minimise the risk of odour, noise and vibration nuisance. Note: This dimension may be subject to change, depending on the local circumstances and submission of proposals.

**Table 4 Minimum Distances of Edge of Wet Well Hard standing from Property Boundary**

<b>Pumping station type</b>	<b>Minimum distance (m)</b>
Type 1	5
Type 2	10
Type 3	15

2. The pumping station shall not be located where it might be susceptible to flooding at a frequency of more than 1 in 30 years. All electrical control equipment shall be sited above the 1 in 200 year flood level.
3. Pumping stations shall be located so that they are accessible to Scottish Water at all times for operation and maintenance.
4. Figures 27 and 28 show minimum site boundary clearance around a kiosk, wet well and valve chamber.

### **2.26.2 Site Access**

1. The pumping station shall not be situated within a public or private road, in locations that may be used for car parking, in places where maintenance work may obstruct rights of way or where there is a risk of harm from moving vehicles to Operatives carrying out maintenance activities.
2. A safe and reasonable means of vehicular access shall be provided to the pumping stations at all hours for the purposes of repair and maintenance. Access shall be directly from the public road or

by the provision of a dedicated access road. Vehicles shall not be permitted to park in front of the vehicle access point to the pumping station. Long reversing routes are not acceptable. Shared access with domestic driveways is not suitable.

3. Provision shall be made for access by a tanker to empty the wet well and any storage in the event of failure.

4. The provision shall allow for access by a tanker with sufficient capacity to completely empty the wet well (including any provision for storage above the stop levels) and any resulting upstream in-sewer storage up to a maximum of 18,000 litres (4,000 gallons).

5. The site of the pumping station and any access road shall be suitably surfaced to ensure reasonable access for vehicles and plant, and to facilitate the various maintenance operations.

6. The gradient of the site shall be as level as possible to facilitate vehicle movements.

### **2.26.3 Site Layout**

1. The site and access shall be arranged so that:

- a) there is a parking space to accommodate a tanker;
- b) there is sufficient space between the various units on the site to enable maintenance operations to be carried out safely;
- c) there is sufficient space to carry out the chosen method of pump maintenance safely;
- d) the doors of the kiosk open safely;
- e) the pump delivery pipework (within the wet well) is opposite the inlet sewer;
- f) that there is no risk to any adjacent SUDS features from sewage discharge during failure

Note: The Local Planning Authority may determine the requirements for fencing, site layout, landscaping, etc., under the Planning Application but due regard shall be given to health and safety considerations.

2. Pumping stations shall be secure in their own right without having to rely on security fencing. Kiosks and all access covers shall be locked and secure in their own right.

3. For additional security, some pumping stations may require a fenced compound. The developer shall consult Scottish Water to determine the security needs for all pumping stations. Scottish Water will take account of public safety, the likelihood of vandalism, the extent of pedestrian traffic (e.g., near schools) and whether chemical dosing is required.

4. Where security fencing is required by Scottish Water, this will generally be a steel security fence. The height and type shall be agreed with Scottish Water.

Note: Gates shall provide a similar level of security with slide bolt and padlock.

5. If chemical dosing is provided on site, security arrangements shall be agreed with Scottish Water.

6. For Type 1 and Type 2 pumping stations adjacent to a minor road with adequate parking, no on-site provision of parking will be necessary.

Note: The Roads Authority may require the provision of on-site parking as part of any Planning Application.

7. Where access is from a traffic-sensitive street or other major road, or where parking provision is unlikely to be available without obstructing the road, provision shall be made for a tanker to access and park on or adjacent to the site (e.g., in a lay-by). When accessed via a major road, any entrance

gates shall be set back from the road at least one vehicle length, based on the largest vehicle likely to visit the site. If outward opening, the gates shall be set back by the width of the leaf of the gate.

8. On-site tanker parking shall be hardstanding and surrounded by a 125 mm kerb upstand. Where HGV access is required, the hardstanding shall be 200 mm thick reinforced concrete on 500 mm type 1 granular sub-base. For smaller vehicles, permeable hardstanding may be provided.

9. An area of impermeable hardstanding shall be provided around the wet well opening to provide a safe working area and footage for the lifting gantry. For Type 1 and Type 2 pumping stations, the hardstanding shall be a minimum of 750 mm wide on all sides of the opening. For Type 3 pumping stations, the hardstanding shall be a minimum of 1500 mm wide on all sides of the opening.

10. For other access covers (excluding the wet well), an area of permeable hardstanding with a minimum of 750 mm width shall be on all sides of the wet well with a minimum of 1m hardstanding in front of the kiosk.

11. For pumping stations in a fenced compound, the whole area shall be covered with hardstanding.

12. For pumping stations not in a compound, unpaved areas shall be landscaped to match the surface of the area around the pumping station.

13. The top of the wet well and the valve chamber covers shall be flush with the finished ground level which shall not form a hollow that could flood in the event of pump failure or gather surface water.

14. The last access point on the gravity sewer system upstream of the wet well shall be located to allow overpumping and isolation of the wet well.

15. Typical pumping station layouts are shown in Figures 27 and 28.

#### **2.26.4 Kiosk Positioning**

1. The kiosk shall be positioned so that:

- a) there is a minimum of 3 m between the kiosk and any vent from the wet well i.e. access cover or vent pipe;
- b) there is a minimum of 1 m of hardstanding in front of the kiosk;
- c) the kiosk does not obstruct the erection and use of a portable lifting gantry of the type used by Scottish Water;
- d) Operators can have an unobstructed view of the top of the wet well whilst attending the control panel;
- e) the doors of the kiosk do not open onto any access cover/manhole or cause an obstruction;
- f) no danger will arise to operators through working on, or operating the equipment within, the kiosk due to the access covers of the wet well, valve chamber, etc., being open;
- g) the base of the kiosk is above flood level;
- h) the kiosk is outside of any hazardous areas;
- i) in Type 3 pumping stations, there is sufficient space to offload and position a mobile generator adjacent to the kiosk.

2. Where there is no separate enclosed compound, the kiosk doors shall open towards the footway. The kiosk shall be at least 1 m from the footway or, where there is no footway, at least 2.5 m from the carriageway. Where there is no footway, the kiosk doors shall not open towards a carriageway.

3. The kiosk shall not be sited on private ground.

### **2.26.5 Storage on Site**

1. To ensure that sewage flooding does not occur at, or upstream of, the pumping station during plant or power failure, additional storage shall be provided. This storage shall be above the high-level alarm and below the invert of the lowest connected disconnection manhole.
2. The plan area of the wet well below the level of the high-level alarm float switch level shall not be increased to form any of this required storage provision. Such storage may be provided in:
  - a) any upstream public sewers and public lateral drains and associated manholes and inspection chambers, up to the level of the invert of the lowest disconnection manhole. Storage shall not be provided in private drainage.
  - b) specifically-designed adjacent storage structures that are designed to be self-cleansing.
3. Calculations and associated drainage longitudinal sections of the required and available storage capacity shall be submitted to Scottish Water for approval prior to construction.
4. For foul pumping stations, as a minimum, the storage shall equate to 160 litres per dwelling, and for commercial or industrial developments one hour of peak design flow.

### **2.26.6 Hydraulic Design of Pumping Stations**

1. The discharge flow rate of the pump units in foul pumping stations shall be the greater of:
  - a) half the peak design flow rate (see Clause 2.21.1); and
  - b) the flow rate required to achieve a minimum flow velocity in the pumping main in accordance with Clause 2.25.3.1.
2. Where there are limitations on the capacity of the downstream network to accept the instantaneous design pumped flows, consideration shall be made as to amendments that could be made to limit the flow and, therefore, the risk of negative impact on the downstream network. This may include (but is not limited to) the proposal of a smaller bore rising main, change to proposed pump model or the use of variable speed drives to limit the flow under conditions where the receiving sewer capacity is reduced.

## **2.27 PROVISION OF PUMPING MAINS**

### **2.27.1 Layout and Marking**

1. As far as practicable, pumping mains shall be laid in roads, footpaths or public open space where they are reasonably accessible. Pumping mains shall not be laid in enclosed private land.
2. Pumping mains shall be a minimum of 3 m from any building or structure.
3. Minimum depths of cover to the crown of pumping mains without protection shall be as follows:
  - a) domestic gardens and pathways without any possibility of vehicular access – 0.9 m;
  - b) domestic driveways, parking areas and yards with height restrictions to prevent entry by vehicles with a gross vehicle weight in excess of 7.5 tonnes – 0.9 m;
  - c) domestic driveways, parking areas and narrow streets without footways (e.g., mews developments) with limited access for vehicles with a gross vehicle weight in excess of 7.5 tonnes - 0.9 m;
  - d) agricultural land and public open space - 0.9 m; and
  - e) other roads and parking areas with unrestricted access to vehicles with a gross vehicle weight in excess of 7.5 tonnes - 1.2 m.

4. As far as practicable, pumping mains shall be laid in straight lines. Where bends are used, they shall be preformed and of long radius type. Bends shall be located in places where the location of the bend can be adequately marked with a marker post.

5. Land use surveys, "walk over", corrosion, soil chemistry and resistivity surveys shall be carried out (as appropriate) to determine the routing, material used and the degree of corrosion protection required for pumping mains in contaminated or aggressive soils, where potentially vulnerable pipe materials are being considered.

6. The route of a cross-country pumping main shall be marked at every field boundary and, where practicable, at every change of direction by approved concrete marker posts. The words "PUMPED SEWER" and the depth to the top of the pipe in metres shall be indelibly marked on the marker post.

7. For pumping mains, non-degradable marker tape shall be laid 300 mm above the top of the pipe. For a non-metal main, the marker tape shall incorporate a trace wire brought to the surface at a marker post every 1000 m (approximately) and connected to terminals on the marker post. At the pumping station, the tape shall enter through a sealed duct, 300 mm below the finished paved area, and shall be terminated with 1 m of wire coiled inside the valve chamber. At the discharge end of the pumping main, the tape shall be terminated as directed by the Scottish Water.

### **2.27.2 Pump Head Calculation**

1. The static head shall be calculated using the average operating level between start and stop in the wet well and the invert of the pumping main in the discharge manhole. For pumping mains that are undulating, the designer shall also consider the hydraulic gradient along the full longitudinal section of the pumping main to ensure that the effect of any high points is included in the static head assessment.

Where there is a large variation (eg >1500mm) between normal operating start/stop levels that would result in a significant variation of the pumped flow rate, two system curves using static heads associated with both start and stop levels shall be plotted against the proposed pump curve to demonstrate the variation in pass forward flow.

2. The designer shall ensure that the pump is capable of pumping down to snore level for well cleaning purposes, and of operating with the pump well full (e.g., after a power supply interruption) without adverse effect on the pumpset.

3. The pumping main internal diameter shall be selected to give the optimum design for life cycle cost by keeping friction losses at the lowest practicable value.

### **2.27.3 Hydraulic Design of Pumping Mains**

1. The internal diameter of the pumping main shall be optimised for long-term efficiency. This shall be achieved by:

- a) ensuring that the velocity in the pumping main at the required pumped flowrate is within the range 0.75 metres per second to 1.8 metres per second, with the lower value being the preferred rate;
- b) ensuring that the internal diameter of the pumping main is selected to keep the friction losses over the length of the pumping main as low as reasonably practicable.

2. The minimum pumped flowrate shall be calculated as defined in Section 2.24.6. For long pumping mains where the diameter has been increased to reduce friction losses, the pumped flowrate may require to be increased to meet the minimum velocity necessary for self-cleansing. Where this is contemplated, the designer must also consider the effect on the downstream network and confirm there is sufficient capacity in the downstream network to accept the proposed increase of flows.



3. To assist designers, Table 5 gives limits for the length of pumping main that are deemed acceptable for some of the most common pipe diameters. The maximum lengths are given for each of the low/mid/high points in the range of velocities permitted, and designers shall note the traffic light system used to identify the preferred pipe diameter/velocity options with green being the preferred option.
4. There will be more than one combination of pumped flowrate and pumping main diameter that will meet the requirements for any application. Designers shall utilise life cycle cost (LCC) comparison models of the type published by WIMES to ensure that the combination being proposed represents the lowest LCC option when calculated over a 20-year period.
5. The LCC shall also take account of the cost of septicity dosing equipment and chemicals over the 20-year period should the risk of septicity be calculated as "high" using the procedure in Clause 2.25.4.
6. Any proposal that deviates out with these limits must be submitted with supporting life cycle cost comparisons to Scottish Water for approval via the Waiver Process at the design stage of the pumping station. A standard LCC model is available from Scottish Water.
7. To assist pumping reliability, only certain types of impeller shall be permitted for sewage pumping applications. For smaller diameter pumping mains, macerator or vortex-type impellers shall be utilised to minimise the risk of blockage. A guide to permissible impeller types is given in Table 5.
8. The purpose of Table 5 is to ensure that friction losses are not unnecessarily high due to the impact this has on the operational efficiency of the station and the associated life cycle costs.
9. The traffic light system has been used within the Table with green denoting the preferred velocity for each pipe diameter.
10. The flowrates associated with the velocities have been determined for a range of pipe diameters with assumed internal diameters. This is a guide only and shall be checked by the designer.
11. A maximum length of pumping main has been determined based on the friction losses when pumping at various velocities. Any deviation from these maximum lengths shall be discussed with Scottish Water at the earliest possible stage and prior to design completion.
12. Designers shall note that Table 5 is for guidance only. The full site hydraulic design and calculations shall follow the specified approval process.

**Table 5 Maximum Length of Pumping Main and Suitable Impeller Types**

Nominal Bore	Internal Diameter	Velocity (m/s)	Flow Rate (l/s)	Maximum Pumping Main Length at Flow Rate (m)	Suitable Impeller Types					
					Macerator	Vortex	Closed single Vane	Open single Vane	Screw Centrifugal	Special non-clogging centrifugal
63	51	0.75	1.54	150	✓	X	X	X	X	X
		1.28	2.62	75	✓	X	X	X	X	X
		1.80	3.68	50	✓	X	X	X	X	X
90	79	0.75	3.65	300	✓	✓	X	X	X	X
		1.28	6.23	150	✓	✓	X	X	X	X
		1.80	8.76	100	✓	✓	X	X	X	X
110	96	0.75	5.46	400	X	✓	✓	✓	✓	✓
		1.28	9.32	200	X	✓	✓	✓	✓	✓
		1.80	13.11	125	X	✓	✓	✓	✓	✓
125	110	0.75	7.06	500	X	✓	✓	✓	✓	✓
		1.28	12.06	250	X	✓	✓	✓	✓	✓
		1.80	16.95	150	X	✓	✓	✓	✓	✓
160	140	0.75	11.60	600	X	X	✓	✓	✓	✓
		1.28	19.79	300	X	X	✓	✓	✓	✓
		1.80	27.83	200	X	X	✓	✓	✓	✓
180	158	0.75	14.71	800	X	X	✓	✓	✓	✓
		1.28	25.10	400	X	X	✓	✓	✓	✓
		1.80	35.30	250	X	X	✓	✓	✓	✓
225	197	0.75	22.93	1000	X	X	✓	✓	✓	✓
		1.28	39.14	500	X	X	✓	✓	✓	✓
		1.80	55.04	325	X	X	✓	✓	✓	✓

13. The roughness value used for the design of the pumping main shall be shown in the calculations submitted and shall be in accordance with 'Tables for the Hydraulic Design of Pipes, Sewers and Channels: 8<sup>th</sup> edition. Volume 2' published by HR Wallingford.

i.e., for mean velocities up to 1.1 metres per second  $k_s = 0.3 \text{ mm}$ ;

for mean velocities between 1.1 and 1.8 metres per second  $k_s = 0.15 \text{ mm}$ .

Note: The values above take into account the biofilm that accumulates on mature sewage pumping mains. This biofilm can create higher values of surface roughness than the pipe material exhibits but is lessened by higher velocities in the pumping main limiting the biofilm build up.

14. A pumping main shall be laid to a minimum gradient of 1:500 rising and 1:300 falling, with sewage-type air release valves provided at high points to facilitate air removal. Whilst a continuously-rising pipeline is hydraulically preferable, it is recognised that route topography may introduce undulations, especially for long pumping mains. Where localised river, stream or other surface or sub surface feature is required to be negotiated and a crossing made, the pumping main shall be laid at a steeper gradient local to the surface or sub surface feature with the agreement of Scottish Water.

15. Where pumping mains are undulating or longer than 500 m, the following additional requirements shall be assessed:

- a) retention time and septicity (it may be necessary to use chemical dosing or to reduce retention times by using a smaller main with a smaller pump);
- b) effect of hydraulic surge and cyclic loading on fatigue life of the material (copies of calculations/reports on surge analysis shall be sent to Scottish Water);
- c) the effect of air accumulating at high points in the system (it may be necessary to include special air release valves);
- d) the effect of drawing in of air after running pumps "on snore" (it may be necessary to include a special air release valve);
- e) the provision for access for cleansing;
- f) washout (scour) facilities at any low points.

16. In all cases, a separate manhole and short section of gravity sewer shall be constructed at the end of the pumping main to enable the flow to gravitate to a manhole on the existing public sewer. Detailed design of the entry arrangements shall ensure that sewer maintenance operations can be undertaken at the manhole without difficulty and avoid turbulence which could cause gas formation, surcharge or flooding.

#### **2.25.4 Septicity**

1. The absence of air and oxygen (anaerobic conditions) causes bacterial production of toxic and foul-smelling gases including hydrogen sulphide (H<sub>2</sub>S) and mercaptans. The presence of H<sub>2</sub>S can also be detrimental to the sewer infrastructure (corrosion).

2. The developer shall be responsible for ensuring the risk of anaerobic conditions occurring is assessed and any works necessary to eliminate odours are included in the pumping station design.

3. The risk of septicity occurring shall be classified as high, medium or low as follows:

##### **2.25.4.1 High Risk**

1. The risk of septicity occurring shall be considered to be "high" if any of the following circumstances apply:

- The retention time in the pumping main is in excess of 12 hours;
- The upstream sewerage system contains salt water infiltration due to tidal or other influences.

2. Where there is a high risk of septicity occurring, septicity dosing equipment shall be provided. The design of the septicity dosing equipment installation shall be agreed with Scottish Water.

##### **2.25.4.2 Medium Risk**

1. The risk of septicity occurring shall be considered to be "medium" if any of the following circumstances apply:

- The retention time in the pumping main is between 6 and 12 hours;
- The upstream sewerage system may contain salt water infiltration under abnormal conditions due to tidal or other influences.

2. Where there is a medium risk of septicity occurring, provision shall be made for septicity dosing equipment to be installed.

3. For kiosk-type installations, this shall include a separate concrete plinth suitable for mounting an additional kiosk to house the chemical dosing and storage equipment for the septicity odour control

system. All necessary ducting shall be built in at the construction stage and temporarily sealed until required. The kiosk shall be located within the pumping station boundary.

Installations within a superstructure or other building space shall be designated for septicity dosing equipment.

4. The designer shall ensure that the location of all chemical storage and dosing equipment does not interfere with the normal operation of the pumping station.

#### **2.25.4.3 Low Risk**

1. The risk of septicity shall be considered to be "low" if none of the above conditions for high and medium risk apply.

2. Where there is a low risk of septicity occurring, no provision requires to be made for septicity dosing.

Note: During phased developments where the initial foul sewage flow rate is likely to be significantly below the ultimate design flow, septicity can occur at the pumping station or at the discharge point from the pumping main. This problem shall be avoided by careful design of the wet well sump and/or by provision of chemical dosing facilities.

## **2.28 DESIGN OF PUMPING STATIONS**

### **2.28.1 General**

1. Plant and equipment shall be reliable, efficient and capable of operating between the manufacturer's recommended service intervals without attention or inspection.

### **2.28.2 Blockage Risk Assessment**

1. A blockage risk assessment shall be carried out for all pumping stations. Where this indicates a high risk of blockage occurring, the MCC shall incorporate intelligent control and reversing starters as a means of prevention. Pumping stations shall be deemed to be at a high risk of blockage where any of the following catchment features are encountered:

- a) where there are a number of screened CSOs or detention tanks within the catchment upstream of the proposed pumping station;
- b) where there is a flat catchment prone to deposition, e.g., where self-cleaning velocities cannot be maintained during periods of dry weather flow;
- c) where upstream pumping stations may deliver surges of rags;
- d) where unscreened raw sewage is pumped by a variable speed centrifugal pump.

2. Where a pumping station is deemed to have a high risk of blockage and requires blockage prevention technology, the electrical assembly shall comply with the SW Specifications for Wastewater Pumping Stations and Intelligent Pumping Station Controllers (IPSCs) or else be selected from the range of Scottish Water standard products. This shall include reversing starters or reversing variable speed drives and the control philosophy shall be agreed with Scottish Water. The aim is to minimise the number of choked pump incidents and reactive maintenance tasks through the action of self-cleansing that this technology introduces.

### **2.28.3 Hazardous Area Risk Assessment**

1. The Dangerous Substances and Explosive Atmospheres Regulations 2002 (DSEAR) require the designer to take into account requirements for the protection of workers from fire and explosion risks arising from dangerous substances and potentially explosive atmospheres. Scottish Water have produced a DSEAR risk assessment tool in the form of a Microsoft™ Excel workbook called an

Explosion Protection Document (EPD) (available from Scottish Water on request) that incorporates the Flammable Liquids in Drainage Systems (FLIDS) risk assessment methodology..

Note: Full details are provided in Scottish Water Standards and Specifications Section 204 – DSEAR Compliance.

2. A site-specific Explosion Protection Document (EPD) shall be produced for each pumping station. Existing pumping stations may already have an EPD and designers shall establish this with Scottish Water at an early stage. Where an existing EPD is available, it shall be updated with all proposed modifications to re-assess the risk.

3. For many pumping stations designed to this Specification, where the sewer catchment and subsequent effluent risks are similar, a generic DSEAR risk assessment can be applied. The designer shall use the flow chart in Figure 29 to assess whether this generic assessment can be applied to the proposed pumping station. This will result in one of two outcomes:

- a) the pumping station will be low risk and deemed to be non-hazardous and the generic DSEAR risk assessment applies; or
- b) the pumping station will be high enough risk to require a full site-specific DSEAR risk assessment to be carried out using the Scottish Water DSEAR risk assessment tool.

4. The designer shall record the outcome from the flow chart assessment on the DSEAR Preliminary Assessment Form (see Appendix IX) and include it in the Health and Safety File.

5. Where the flow chart outcome determines that the pumping station is non-hazardous, the generic DSEAR risk assessment document shall be used to produce a site-specific Explosion Protection Document (EPD). This is achieved by inserting the site name and identification details, nodes, pump models etc. in the generic workbook. The resultant EPD shall be submitted to Scottish Water in electronic format and included in the Health and Safety File.

6. Where the flow chart outcome determines that a full site-specific DSEAR risk assessment is required, the designer shall engage the Scottish Water appointed consultant who shall have the necessary specialist training to use the DSEAR risk assessment tool. The risk assessment shall determine the classification and extent of all hazardous areas associated with the pumping station.

7. Wherever reasonably practicable, hazardous areas shall be designed out, or minimised, and shall not contain any equipment that has to be regularly inspected or maintained in excess of normal annual attendance levels.

8. All hazardous areas identified during the DSEAR risk assessment shall have a warning sign affixed. Scottish Water or their appointed consultant shall advise the developer in this respect.

9. A copy of all hazardous area drawings shall be kept in a waterproof pocket inside the control kiosk door as part of the “site” or “abbreviated” O&M manual. The kiosk shall be located outwith any hazardous areas.

10. Appropriate certification shall be included in the O&M manuals to confirm the suitability of the electrical and mechanical equipment for operation in the specified hazardous areas.

#### **2.28.4 Wet Well**

1. The design of the wet well and the sewer inlet arrangement shall ensure satisfactory flow conditions to the pumps and avoid the formation of vortices. This is best achieved by installing the incoming sewer on the centreline between the submersible pump units. An inlet baffle or drop tube terminating above the start level may be provided for the sewer inlet to prevent excessive aeration of sewage or interference with ultrasonic beams used for level sensing.

2. If there are multiple sewers draining to the wet well, a manhole shall be provided upstream of the pumping station to combine the flows into a single pumping station inlet pipe.
3. A larger wet well, separate storage tank or enlarged sewer may be needed in order to provide additional storage and thereby reduce the risk of localised flooding or pollution during plant or power failure. If the wet well is very deep, Scottish Water may require additional safety measures to be installed within the wet well for maintenance purposes.
4. Benching shall be provided to eliminate "dead zones" in the wet well where siltation would otherwise occur. Benching shall start no more than 100 mm from the pump unit volute. The slope of the benching shall not be flatter than 60° to the horizontal. The area under the pump shall be as small as possible to ensure effective well cleansing; flat floor areas shall be kept to a minimum.
5. The design of the wet well and the sewer inlet arrangement shall ensure the following:
  - a) the formation of free surface and submerged vortices, which are damaging to the pump units, is avoided;
  - b) flow is presented to the pump units in accordance with the pump manufacturer's recommendations and without excessive pre-swirl or air entrainment; and
  - c) the wet well is materially self cleansing in terms of grit, solids and, as far as practicable, positive buoyancy material.
6. The wet well shall be designed, as far as practicable, to eliminate the need for man-entry for maintenance. No permanent ladder or step rungs shall be located in the wet well.
7. Provision for isolating the incoming flow by means of a hand-operated valve or penstock shall be located in the wet well of the pumping station. The valve operating spindle shall be extended to a point just below the finished ground level and be accessible through a removable cover. An operating key shall be stored in the kiosk.
8. A typical general arrangement of a wet well two-pumping station is shown in Figure 30.
9. Pipework within the wet well shall be ductile iron. Corrosion protection shall comply with the relevant requirements within the 'Water Industry Mechanical Electrical Specification (WIMES) 4.01 – Paints and Polymeric Coatings for Corrosion Protection'. Where small bore pipework is required for macerator type pumping station design, alternative materials may be considered by Scottish Water.
10. The wet well shall preferably be of circular section and shall consist of one of two options:
  - a) prefabricated plastic wet wells;
  - b) reinforced concrete wet wells.

### **Prefabricated Plastic Wet Wells**

11. Scottish Water have developed a range of standard products for many of their processes and asset types. Developers may utilise a Scottish Water standard product (prefabricated plastic) wet well made from prefabricated plastic and obtained from a Scottish Water Approved Framework Supplier. The standard wet well incorporates pre-installed pumps and pipework to minimise the amount of site work required. A double skin provides plastic shuttering for efficient installation of the concrete surround.

### **Reinforced Concrete Wet Wells**

12. For reinforced concrete wet wells, the minimum factor of safety against flotation for empty structure subject to groundwater pressure is 1.1. This shall only be used where the maximum groundwater level can be assessed accurately or a design groundwater level and finished ground level is being used.

13. Precast concrete shall conform to BS 5911-4 or BS EN 1917. Joints between precast components shall provide equivalent water resistance, as specified in BS EN 1992-3. The wet well shall be surrounded with not less than 150 mm thickness of Grade GEN3 concrete.

14. If constructed of in-situ concrete, the wet well shall be designed in accordance with BS EN 1992-3. The cover slab shall be either designed and constructed to BS 5911 or designed to BS EN 1992-1 with an applied loading equal to the accidental wheel loading. The minimum cover shall not be less than 40 mm, provided this meets the requirements of BS 8500-1 and BRE Special Digest 1. All concrete water-retaining/excluding structures shall be designed to satisfy cracking requirements for flexural and thermal loading. The standard concrete mix based upon BS 8500 is C28/35 – general water-retaining (and watertight) structural applications. Reinforcement shall be designation H high yield steel with a design stress of 500 N per mm<sup>2</sup>.

15. Where a pumping main passes through the wall of a structure, the pipe manufacturer's recommendation shall be followed to safeguard the integrity of the main from differential settlement/movement.

### **2.28.5 Valve Chamber**

1. The valve chamber shall be separate from the wet well. Pipework between the wet well and the valve chamber shall include two flexible couplings suitably spaced to accommodate differential settlement. Valves shall not be installed in the wet well.

2. For Type 1 pumping stations only where the pumping main length is less than 5m and where there is no risk of surcharge of the outfall from the pumping main or damage to the pump units from run back, valves may not be necessary. The design shall be agreed with Scottish Water.

3. Depending on pumping station type, the valve chamber shall house the following:

- a) for any type of pumping station, one gate valve per pump unit mounted horizontally in the pump unit outlet pipework and arranged to isolate the pump units from the pumping main;
- b) for any type of pumping station, one check valve per pump unit, mounted horizontally in the pump unit outlet pipework on the pump side of the gate valves and arranged to prevent flow reversal under normal operating conditions; and
- c) for Type 2 and Type 3 pumping stations, a gate valve and 100 mm diameter female Bauer coupling, mounted vertically in a tee piece in the pumping main, downstream of the gate and check valves. This shall be suitable for connecting to a flexible hose to allow the use of a mobile pump during plant maintenance or failure.

4. Valves shall comply with the specifications given in Section 3D and be fitted with hand wheels.

5. A typical valve chamber arrangement is shown in Figure 30. The valve chamber headroom shall be 1.6 m from the base slab to the finished ground level. Where 1.6 m depth cannot be met, agreement shall be sought from Scottish Water.

6. The valve chamber shall not be made unnecessarily deep to avoid the requirement for full-sized covers.

7. The valve chamber walls shall be either brick built, reinforced concrete or pre-cast concrete construction. A typical arrangement is shown in Figure 30.

8. The valve chamber shall be rectangular in shape. The orientation of the pipework within the valve chamber shall normally allow the pump delivery pipework to enter one side of the valve chamber and the pumping main to leave from the opposite side.

9. The valve chamber pipework arrangement shall be designed in conjunction with the wet well pipework and access cover arrangement as the spacing between the wet well pipework is largely influenced by the orientation of the valve chamber pipework.

10. Pump discharge pipework in the valve chamber shall be joined using a combination of a long radius bend and a radial T-piece. The Bauer connector shall be installed vertically on a straight T-piece.

11. The valve chamber shall be designed to provide between 300 mm and 500 mm of clearance between pipe and the valve chamber floor, and a minimum 500 mm clearance between flanges on fittings and the adjacent wall or roof.

#### **2.28.6 Valve Chamber Drainage**

1. The valve chamber shall remain empty of leakage or groundwater at all times to facilitate access and preserve the condition of valves and pipework.

2. Where the highest possible water level in the wet well is below the floor level of the valve chamber, a gravity drain from the valve chamber to the wet well may be provided. The gravity drain to the wet well shall be complete with an insertion-type upstream clamp duck bill non-return valve.

3. Where the valve chamber is in a designated hazardous area, all equipment must be suitable for installation within the respective zonal classification.

#### **2.28.7 Access into Wet Well and Valve Chambers**

1. Openings in access covers shall be large enough for pumps and valves to be lifted easily and safely out of the wet well/chamber for above-ground inspection, maintenance or replacement. Openings shall not be smaller than 600 mm x 675 mm.

2. Wet well openings shall have the following features:

- a) covers shall be lockable and fabricated from galvanised steel, finished flush with the finished ground level and provide a non-slip surface;
- b) hinged covers shall be provided. The hinged cover shall incorporate a facility for securing a recessed padlock and each lid shall have assistance to ensure a lifting effort not exceeding 25 kgF. Scottish Water shall determine the padlock type;
- c) in a closed position, the cover shall withstand a 5 tonne static wheel load in accordance with FACTA (Fabrication Access Covers Trade Association) class B loading. Where there is a risk of traffic loading on the cover, the cover shall withstand FACTA class C loading as a minimum;
- d) for all pumping station wet wells, a hinged safety grid in four leaf sections shall be provided below the cover configured to facilitate the use of a Scottish Water pump chain lifting adaptor. These shall be capable of withstanding a 250 kg load. The lifting effort for each safety grid shall be no greater than 25 kgF;

3. Valve Chamber openings shall have the following features:

- a) covers shall be lockable and fabricated from galvanized steel, finished flush with the cover slab and provide a non-slip surface
- b) hinged covers shall be provided. The hinged cover shall incorporate a facility for securing a recessed padlock and each lid shall have assistance to ensure a lifting effort not exceeding 25 kgF. Scottish Water shall determine padlock type
- c) in a closed position, the cover shall withstand a minimum 5 tonne static wheel load in accordance with FACTA (Fabrication Access Covers Trade Association) class B loading. Where there is a risk of traffic loading on the cover, the cover shall withstand FACTA class C loading as a minimum;
- d) the cover frames shall provide facilities for demountable handrailing which can be



erected prior to any maintenance being undertaken within the valve chamber. Depending on the site conditions, the handrail may be fixed permanently. Chains shall not be used for handrails.

- e) the handrails shall withstand an impact load of 125 kg from a height of 1.85 m through a footprint of 400 mm<sup>2</sup>. Handrails shall be capable of being released to allow access to the equipment from all sides. The stanchion sockets within the frame shall be flush with the concrete slab and be sealed to prevent debris entering when not in use.
- f) Access to below-ground valve chambers may be by either fixed ladders or a minimum of plastic encapsulated steel double step rungs conforming to BS EN 13101.
- g) Valve chamber cover frames shall incorporate a hinged open mesh safety grid below the main cover in accordance with Scottish Water standard specification;
- h) The opening covers shall extend over the full valve chamber.

### **2.28.8 Ventilation of Wet Well**

1. Where the wet well cannot be vented through the upstream sewer system, ventilation shall be provided in accordance with one of the following methods:

- a) the installation of a stack with a minimum diameter of 75 mm and a minimum height of 4 m with a galvanised mild steel mesh at the top;
- b) an air inlet/outlet vent positioned at least 3 m from the kiosk/building and a minimum of 15 m from any habitable building.

2. The selection of the method of venting shall take into account the risk of odour nuisance.

3. Vent shall open at the "high point(s)" of the wet well. Bends in vent pipes shall be large radius; elbow bends shall not be used. Vent pipes shall be installed in such a way to avoid them becoming ineffective due to trapped water (rain, condensation, etc.) and the outlet of the vent stack shall be fitted with a grille and a mushroom shield. The external shape and colour of the vent stack shall comply with local planning requirements and conform to architectural features of similar local installations.

### **2.28.9 Cable Ducts**

1. Cable ducts shall be provided to route cables underground (refer to Section 3.13.4).

## **2.29 DESIGN OF KIOSK**

### **2.29.1 General**

1. The kiosk shall be divided into control and metering compartments by an internal partition to facilitate independent access for the electricity distribution network operator to their equipment. The control compartment shall house all equipment owned by Scottish Water. An aperture shall be provided through the partition, suitably finished and sealed, for the meter tails from the control compartment. A typical kiosk layout is shown on Figures 31 and 32. The small wall mounted two pump panel, as shown in Figure 31 and Figure 32, are based on the Scottish Water Motor Control Centre Product Catalogue, and can accommodate standard iMCC/MCC cubicles with separate control section and built-in telemetry.

2. The kiosk shall, as a minimum, enclose the following equipment:

- a) the electricity distribution network operator's supply and metering equipment. This shall be housed in a separate section of the kiosk;
- b) the electrical assembly;
- c) the telemetry outstation;
- d) a kiosk heating and lighting system; and
- e) a RCD switched 240 V socket.

## 2.29.2 Kiosk Construction

1. The kiosk shall be of a non “walk-in” design with an open base and an overall pitched roof sloping down at approximately 5°. The roof canopy shall have an overhang to provide a degree of drip protection when the doors are opened. The gap formed by the overhang lip shall be kept to a minimum and the thickness of the overhang shall be sufficient to resist casual vandalism.
2. Soffit vents concealed by the kiosk roof canopy shall provide sufficient natural ventilation to prevent excessive internal temperatures due to solar gain and equipment heat losses.
3. Insect (midge) mesh shall be fitted to all vents. The kiosk shall be designed such that there is a gap between the top of the partition and the underside of the roof to allow air movement between the control and metering compartments.
4. The metering compartment shall be suitable for low voltage incoming mains power supplies not exceeding 45 kVA. No equipment shall be mounted by the kiosk supplier which shall solely accommodate the following electricity distribution network operator’s equipment:
  - Service cable head and cut-out fuses;
  - Direct-connected electricity meter;
  - 4-pole switch-disconnector;
  - Main earth terminal (except where the type of system earthing is TT).
5. The kiosk supplier shall provide meter tails and an earth cable from the control compartment into the metering compartment for termination by the electricity supplier to their equipment.
6. The walls and doors of the kiosk shall be constructed from GRP encapsulated, marine quality plywood panels with a minimum thickness of 18 mm. Panels shall be joined together using stainless steel bolts and any gaps between panels sealed with a non-degradable mastic sealer. The edges of the kiosk doors and door frames shall be stiffened by encapsulated steel sections.
7. Where necessary, to support the control panel and all associated equipment, either:
  - a) the rear wall of the kiosk shall be stiffened by encapsulated steel sections; or
  - b) a suitably-sized, 18 mm thick, varnished, marine quality, plywood backboard meeting the requirements of BS 1088-1 shall be fitted to the rear internal wall of the kiosk.
8. Where option a) is selected in Clause 2.27.2.7 above, a suitably-sized, 18 mm thick, varnished, marine quality, plywood backboard shall also be fitted to the rear internal wall of the kiosk to accommodate the electricity distribution network operator’s incoming supply and metering equipment.
9. The walls of the kiosk shall have returned bottom flanges, suitably drilled to accommodate the bolts for securing the kiosk to the plinth. The bolt holes shall be reinforced with minimum 5 mm thick, galvanised steel plates, encapsulated within the bottom flanges.
10. The quality of kiosk construction shall ensure the following:
  - a) the thermal transmittance of the kiosk shall not exceed 1.5 W/m<sup>2</sup>K;
  - b) the fire resistance (retention of stability, integrity and insulation) of the kiosk shall be Class 2 in accordance with BS 476-7, when tested in accordance with BS 476-20 to -23 for a period exceeding 30 minutes;
  - c) the IP rating of the kiosk shall be IP55 (minimum).
11. Scottish Water may specify alternative forms of kiosk construction to GRP encapsulated marine quality plywood in locations subject to vandalism (as advised by the local police authority).

12. The doors of the kiosk shall be fitted with vandal-proof, stainless steel hinges and self-latching stays to restrain the doors in the fully-open position. One door shall have stainless steel shoot bolts at the top and bottom.

13. The developer shall undertake a risk-based assessment of likelihood of criminal damage. Where there is justifiable evidence of abnormally high risk of criminal damage, approval shall be obtained from Scottish Water to upgrade the kiosk to a steel security-rated product certified to LPS 1175 SR3 (or higher), with padlock shrouds, that can be procured from the Scottish Water Security Framework supplier. In these cases, the communications medium shall be a PSTN line as external antennae would present an unacceptable target for criminal damage.

Note: Examples where a steel security-rated kiosk might be appropriate include where there is physical evidence and/or confirmed reports of existing street furniture having been subject to serious attack or attempts to gain entry/successful breach resulting in operational or financial loss to Scottish Water.

14. Unless the customer impact assessment or Planning Authority require otherwise, the preferred exterior colour of the kiosk shall be BS 4800 14C 39 (Dark Green). The preferred interior colour of the kiosk shall be BS 4800 00E 55 (White). All surface finishes shall be applied in such a manner so as to ensure that the colour is maintained for the design life of the equipment.

15. Suitably-sized weather-proof and vermin-proof ventilation grilles, with fly screens, shall be fitted at low level on one side of the kiosk and at high level on the opposite side of the kiosk to ensure cross-ventilation. Consideration shall be given to the equipment being installed within the kiosk to minimise heat or humidity generated by that equipment. Ventilation shall be sufficient to restrict the temperature in the kiosk, under all weather conditions to a maximum of 40°C at any one time, and to an average of 35°C over 24 hours.

16. In Type 3 pumping stations, a small door or “cat-flap” shall be fitted in the wall of the kiosk opposite the electrical assembly to provide access for standby generator facilities. The “cat-flap” shall be large enough to pass the standby generator cable and connector, and be horizontally hinged at the top. The “cat-flap” shall open outwards and be lockable in the closed position from inside the kiosk with internal shoot bolts.

17. The kiosk doors shall be fitted with a multi-point locking system with hasp and staple. The hasp and staple shall be at least 90 mm long horizontally, 30 mm wide vertically and be suitable for a 30 mm padlock as minimum.

18. The following notices/information plates shall, as a minimum, be fitted to the kiosk:

- a) a notice giving instructions for resuscitation after electric shock to be fixed to the inside of a kiosk door;
- b) for Type 3 pumping stations, a notice giving instructions for connection and use of a standby generator, including instructions for changing back to the mains supply following restoration of supply to be fixed to the inside of the kiosk;
- c) an information plate giving information relating to the pump units (serial/curve numbers, FLC, duty head and flow, etc.), the setting levels of the ultrasonic level controller and the diameter and length of the pumping main to be fixed to the inside of a kiosk door;
- d) a complete set of wiring diagrams for the electrical assembly to be fixed to the inside of a kiosk door in a weatherproof envelope;
- e) a standard, black engraved on yellow “DANGER – Electrical Apparatus” (with flash symbol on a triangle) notice to be fixed to the exterior of a kiosk door. The highest voltage within the kiosk shall be indicated on this label or adjacent. In Type 3 pumping stations, the notice shall be manufactured from a durable plastic material and have dimensions not less than 200 mm by 150 mm; and
- f) an information plate giving the name of the site, the developer’s contact name and emergency contact telephone number to be fixed to the exterior of a kiosk door. The notice shall be manufactured from a durable plastic material and have dimensions not

less than 200 mm by 150 mm.

19. A schematic diagram of the pumping station shall be provided detailing the operating levels and pumping station dimensions which shall be fixed to the inside of the door of the kiosk. The diagram shall be laminated.

20. The kiosk shall be mounted 150 mm above the finished ground level on a concrete plinth. The plinth shall extend a minimum of 125 mm beyond the kiosk walls and have chamfered edges.

21. The surface of the plinth shall be sufficiently level to ensure that the kiosk will seat correctly on the plinth and that the kiosk doors will open and close without any fouling or forcing.

22. All fasteners and shims required to secure the kiosk to the plinth shall be manufactured from stainless steel. The fasteners shall be stainless steel expanding bolt type complete with large washers to prevent damage to the GRP flange. They shall be located at suitable intervals to prevent flange distortion.

23. The bottom flange of the kiosk and plinth shall be mounted on the plinth and shall be sealed with a mastic sealant to prevent water ingress.

### **2.29.3 Kiosk Heating and Small Power and Lighting Arrangements**

1. A single phase and neutral distribution board shall be provided. This shall be suitably rated and labelled for the following duties:

- a) kiosk anti-condensation heater;
- b) kiosk lighting;
- c) kiosk socket outlet supplies;
- d) telemetry outstation;
- e) flowmeter;
- f) spare.

2. The kiosk shall be equipped with a number of suitably-rated, tubular anti-frost heaters. Heaters shall be controlled by tamper-proof thermostats, initially set at 5°C. The final connection to heaters shall be made with white heat-resistant, flexible cable, 85°C rubber insulated (HOFR) to BS 6004.

3. The kiosk shall be provided with a number of suitably-rated, IP54, fluorescent luminaires to give an illumination level of not less than 300 lux within the kiosk. These shall be securely mounted inside the kiosk at roof level to illuminate the control panel and all associated equipment. Luminaires shall be provided with an IP54 On/Off switch, complying with BS EN 60669-1, mounted inside the kiosk, adjacent to a door.

4. One wall-mounted 230 V twin switched socket outlet to BS 1363 shall be provided for each kiosk. The socket outlet shall be protected by a 30 mA residual current device and shall be protected to a minimum of IP54.

### **2.29.4 Telemetry Remote Terminal Unit**

1. A Scottish Water telemetry approved remote terminal unit (RTU) shall be supplied and connected within the pumping station kiosk. Scottish Water shall advise on a suitable RTU and the communication media (e.g., PSTN/GSM/satellite) to be used to interface with the Scottish Water telemetry system, and on the telemetry configuration requirements to accept the new RTU. The RTU shall require at least 450 mm x 600 mm free space on the pumping station kiosk backboard.

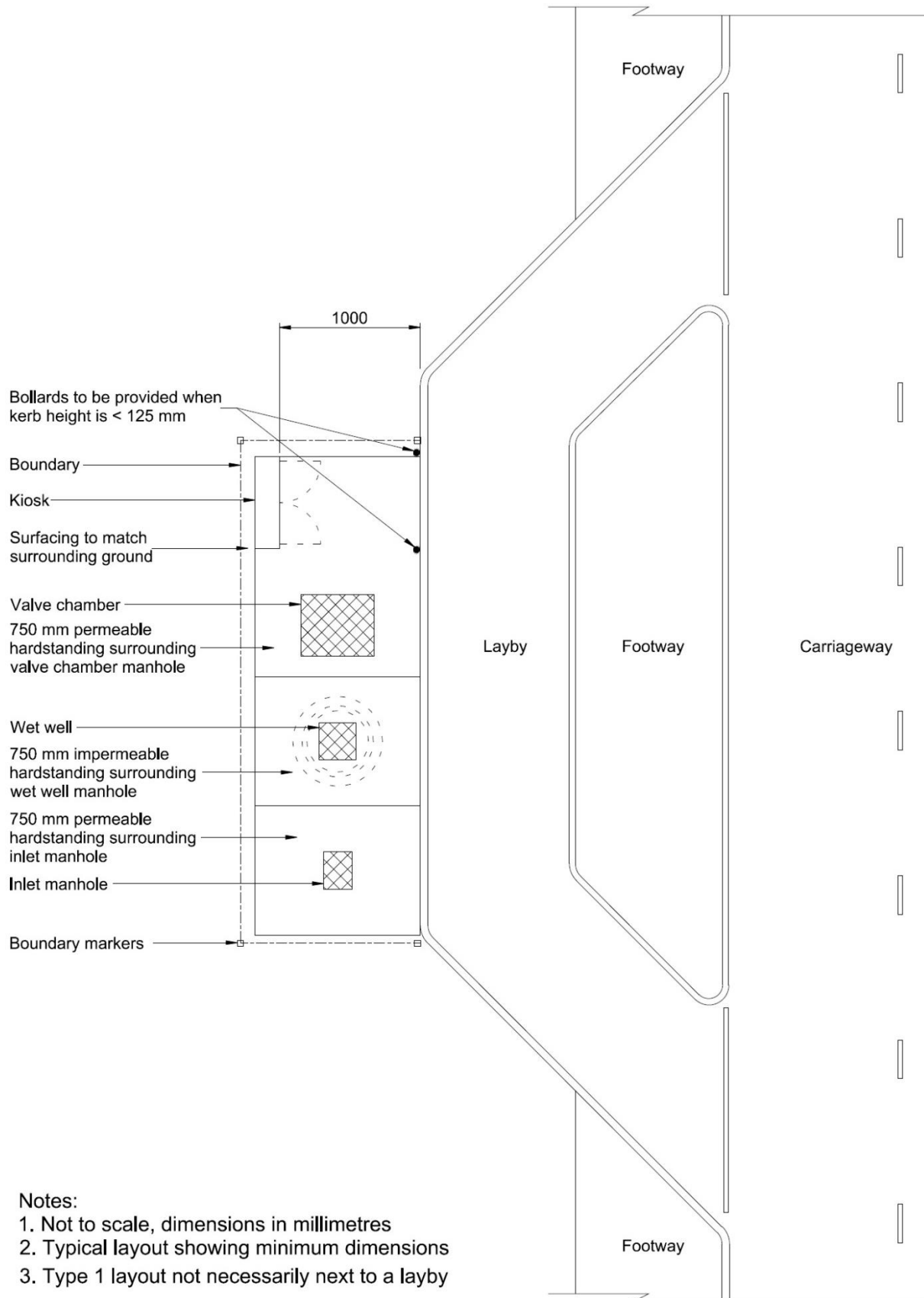
2. The following signals shall be provided in accordance with 'Sewers for Scotland Telemetry Signal Workbook (SSP-SP-SPE-06063351) for Telemetry Monitoring' produced by Scottish Water. The signals are numbered, where this is required, for standardisation.

**Table 6 Telemetry Requirements**

<b>Pseudo Inputs</b>			
a)	Pseudo	RTU mains	states are failed/normal
b)	Pseudo	Site attended key-switch override	states are normal/key-switch override active
c)	Pseudo	RTU battery low	states are low/normal
<b>Digital Inputs</b>			
a)	D1	Site attended key-switch	states are unmanned/manned
b)	D2	Outstation mains failed	states are failed/normal
c)	D3	Standby battery status	states are low/normal
d)	D4	Site power	states are failed/normal
e)	D5	Wet well level high and pumped flow low	states are normal/alarm
f)	D6	Wet well level high and pump failure	states are normal/alarm
g)	D7	Emergency overflow operating (from float switch powered by RTU)	states are alarm/normal
h)	D8	Emergency overflow operating (from high-high level float switch)	states are alarm/normal
i)	D9	Wet well level instrument	states are failed/normal
j)	D10	Outlet flow instrument	states are failed/normal
k)	D11	Foul pump No.1 control	states are unavailable/available
l)	D12	Foul pump No.1 status	states are stopped/running
m)	D13	Foul pump No.1 condition	states are tripped/healthy
n)	D14	Foul pump No.1 seal	states are normal/seal leak
o)	D15	Foul pump No.2 control	states are unavailable/available
p)	D16	Foul pump No.2 status	states are stopped/running
q)	D17	Foul pump No.2 condition	states are tripped/healthy
r)	D18	Foul pump No.2 seal	states are normal/seal leak
s)	D19	Both foul pumps tripped	both foul pumps tripped/healthy
<b>Analogue Inputs</b>			
a)	A1	Wet well level (4-20 mA signal)	
b)	A2	Pumped flow (4-20 mA signal)	
<b>Digital Outputs Facility for:</b>			
a)	Control	Foul pump No.1 remote trip reset	states are normal/reset
b)	Control	Foul pump No.2 remote trip reset	states are normal/reset

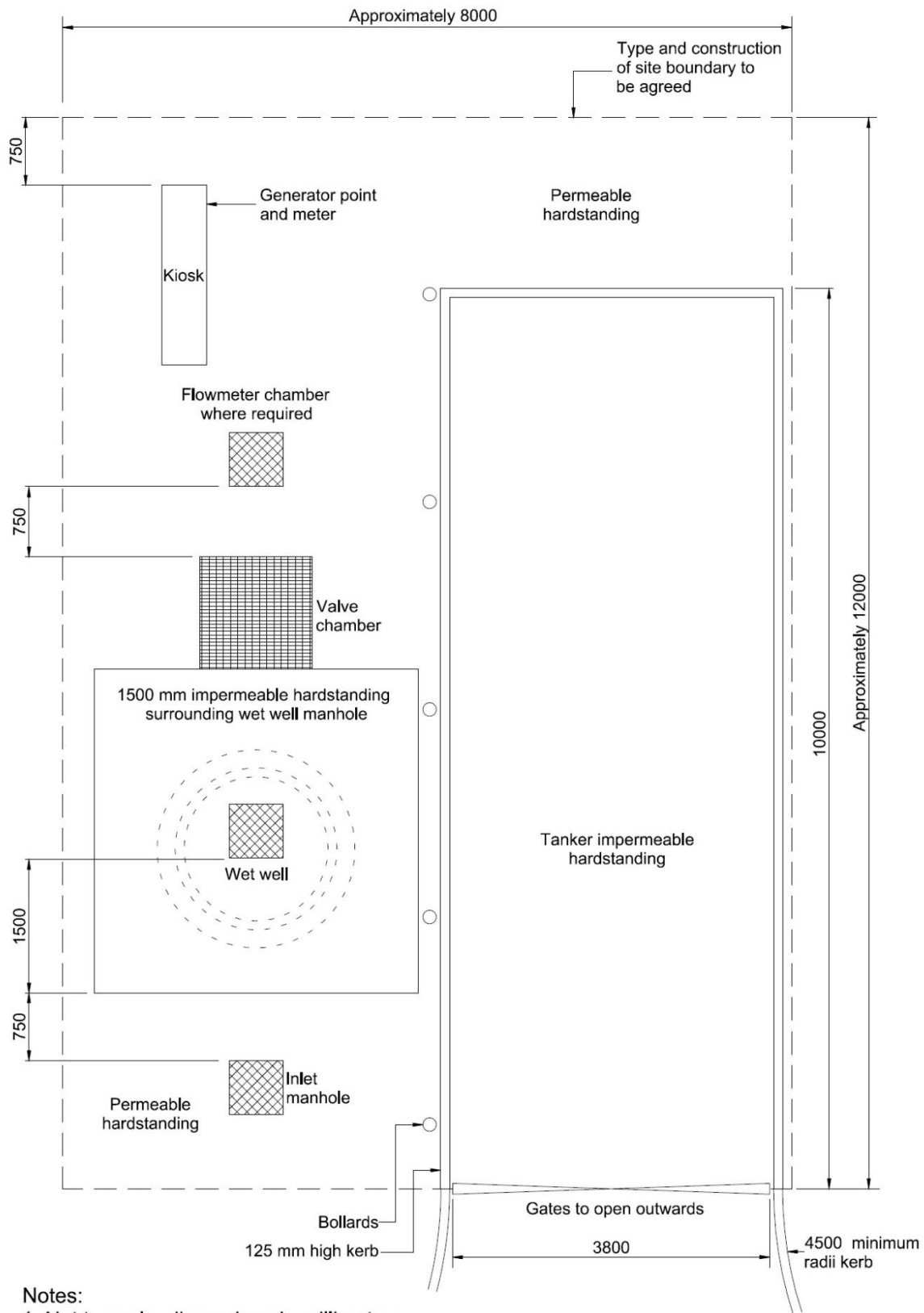
3. Intelligent alarms, i.e., those derived as a result of comparing two or more inputs, shall not be derived in the RTU.

**FIGURE 26  
TYPICAL PUMPING STATION LAYOUT TYPE 1&2**



Not to Scale, dimensions in millimetres  
Full set and standard details, please contact Scottish Water

**FIGURE 27  
TYPICAL PUMPING STATION LAYOUT TYPE 3**

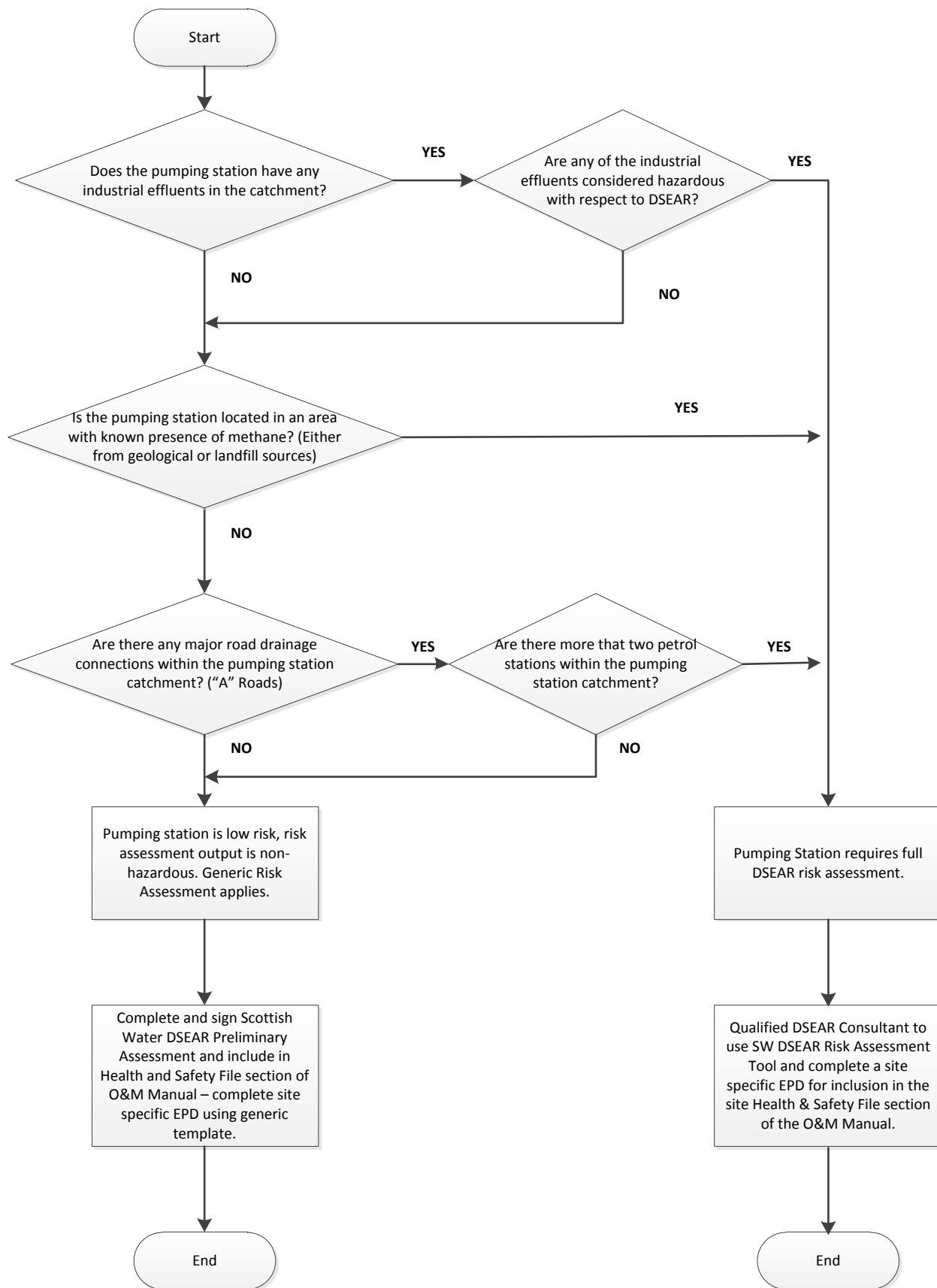


**Notes:**

1. Not to scale, dimensions in millimetres
2. Typical layout showing minimum dimensions
3. There shall be a clear opening in front of the gates to ensure adequate access

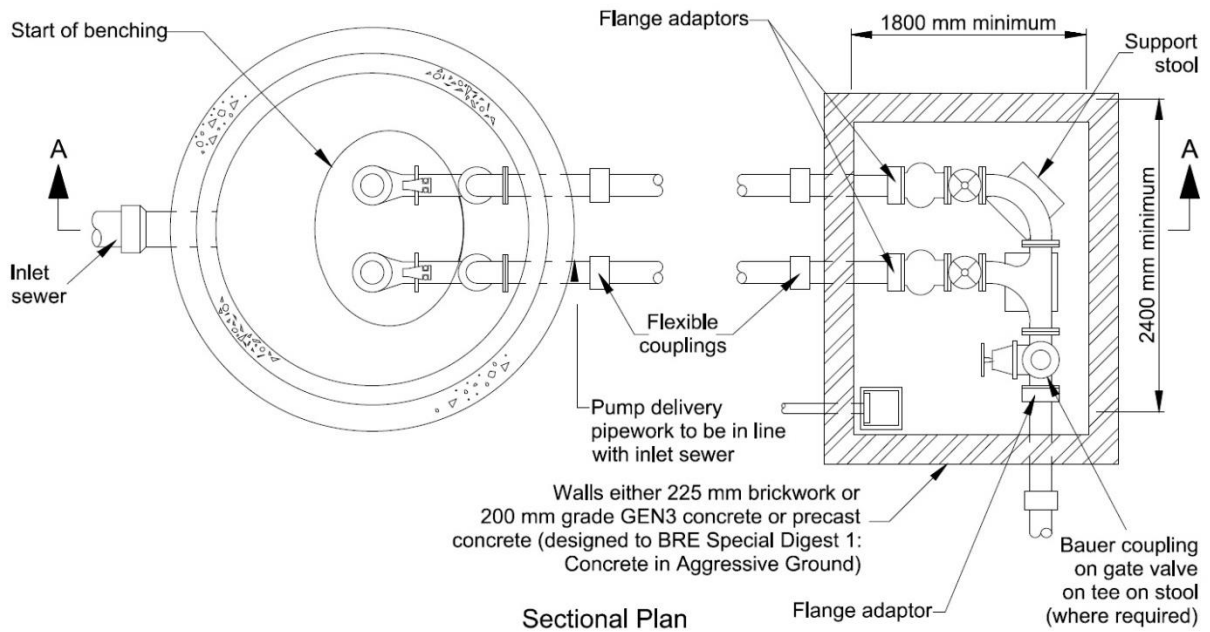
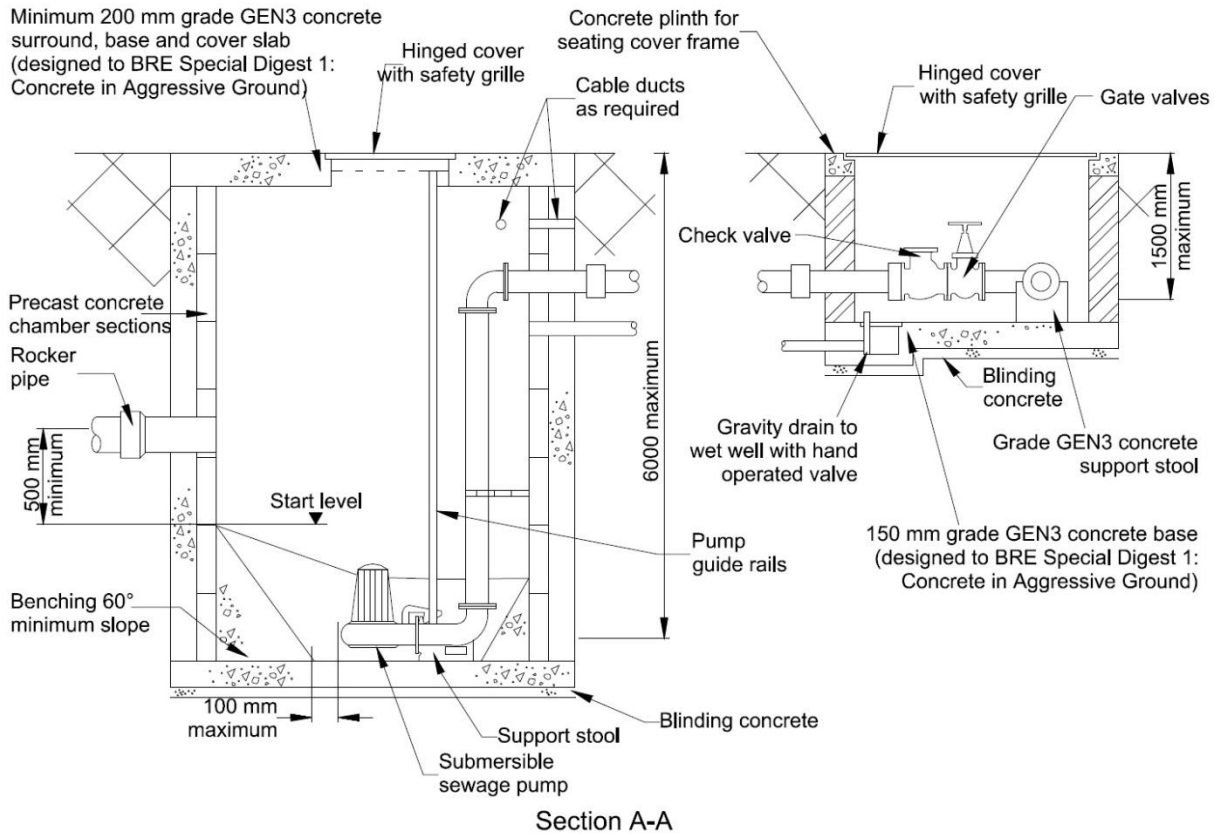
Not to Scale, dimensions in millimetres  
Full set and standard details, please contact Scottish Water

**FIGURE 28  
DSEAR FLOW CHART**



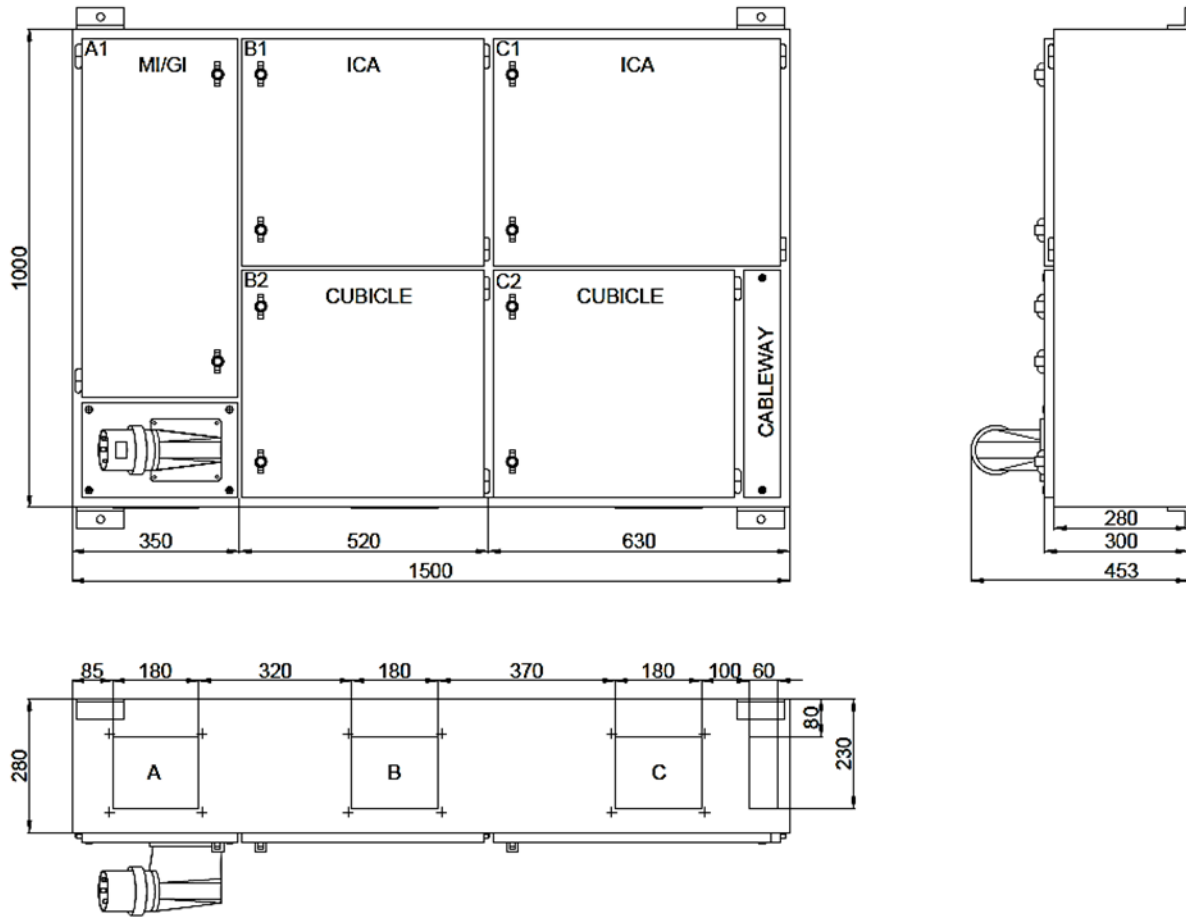


**FIGURE 29**  
**TYPICAL WET WELL LAYOUT**



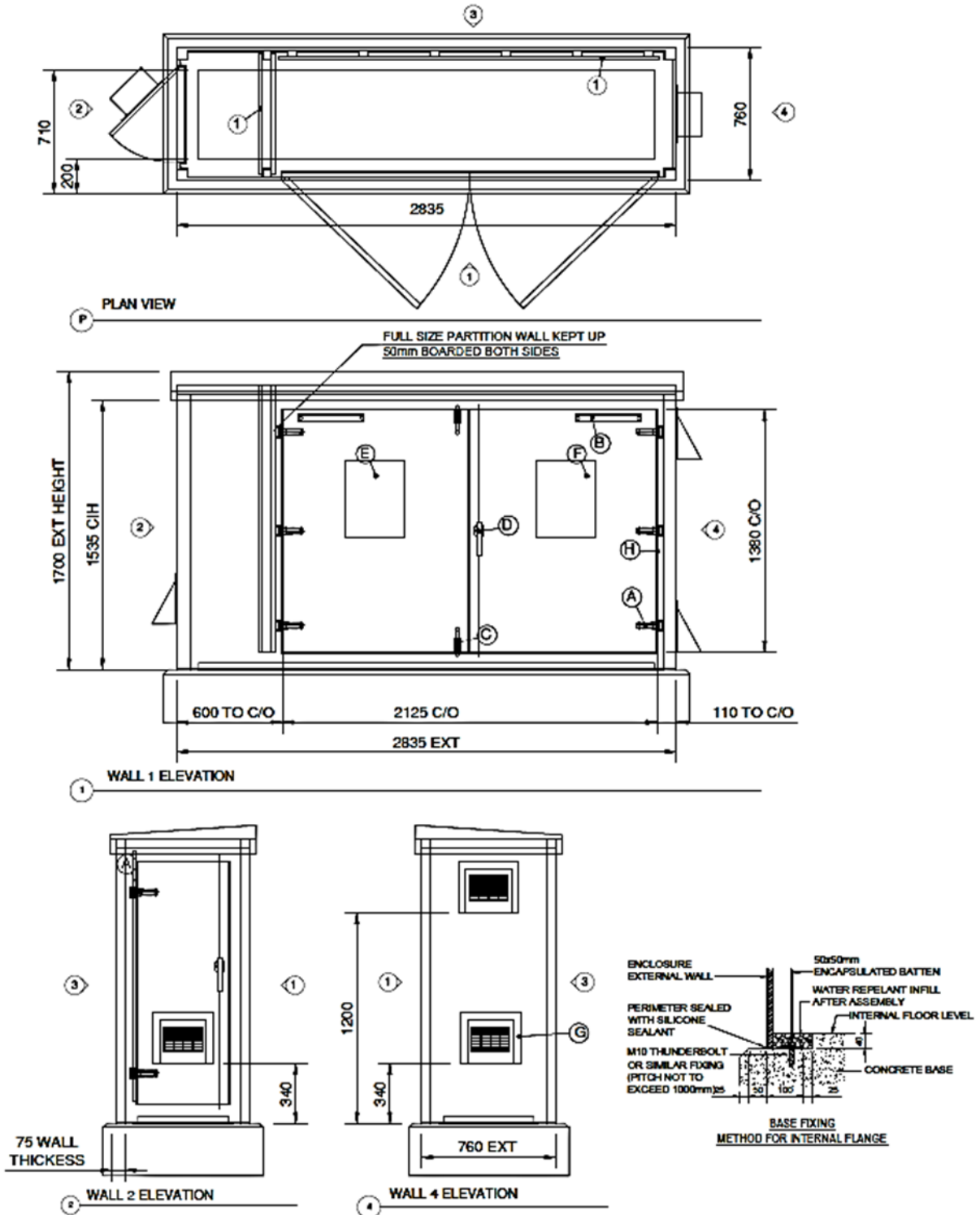
Not to Scale, dimensions in millimetres  
Full set and standard details, please contact Scottish Water

**FIGURE 30  
TYPICAL CONTROL PANEL**



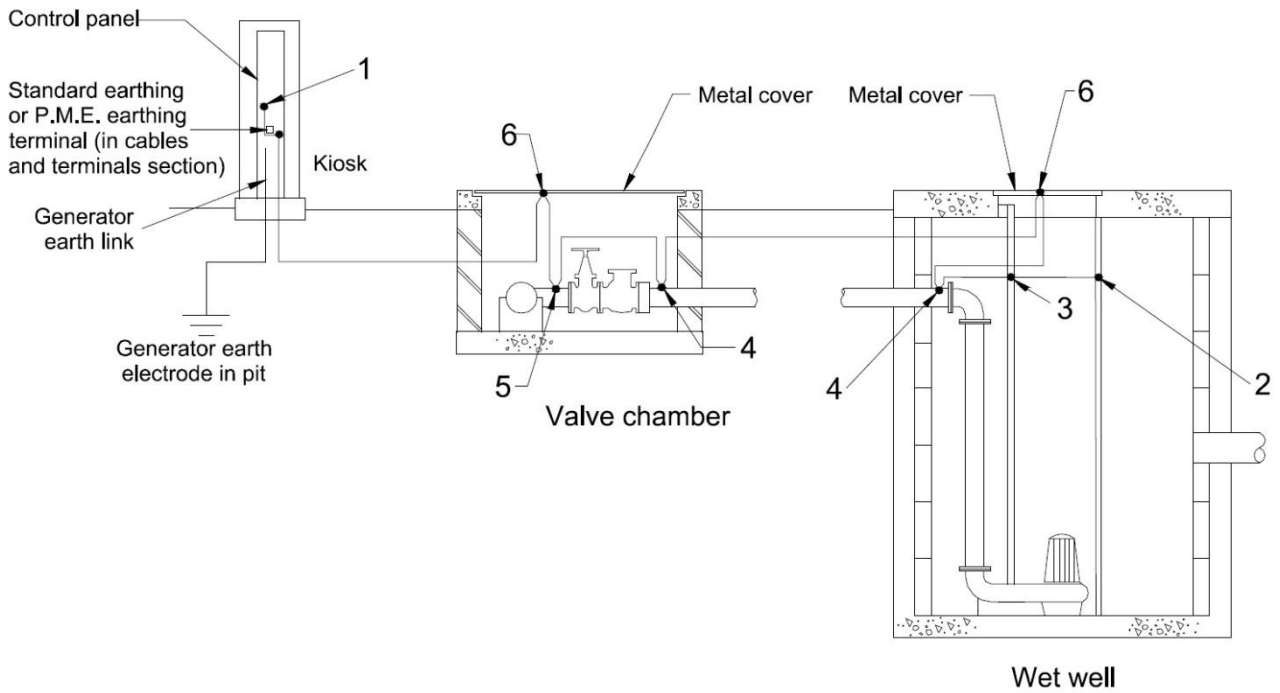
Not to Scale, dimensions in millimetres  
Full set and standard details, please contact Scottish Water

**FIGURE 31  
TYPICAL KIOSK LAYOUT**



Not to Scale, dimensions in millimetres  
Full set and standard details, please contact Scottish Water

**FIGURE 32  
TYPICAL EARTHING ARRANGEMENT**



Note:  
Earth bonding connections indicated thus:



The following actual equipment must be bonded to the earthing terminal:

1. All case earth connections, etc., in the kiosk/building;
2. Pump guide rails;
3. Pump delivery pipes and auxiliary suction pipe;
4. Metal rising main; and
5. Metal cover support frames.
6. The pump casing is connected to the protective multiple earth (P.M.E.) earthing terminal via the flexible cable between the pump and the kiosk/building.

Not to Scale, dimensions in millimetres  
Full set and standard details, please contact Scottish Water

# **PART 3 – MECHANICAL & ELECTRICAL SPECIFICATION FOR PUMPING STATIONS**

This Specification is divided into four Sections:

Section A – Pump Specification

Section B – Motor Specification

Section C – Electrical Specification

Section D – Valve Specification

Part 3 supports the technical specification for the design and construction of pumping stations in Section 2D. As such the scope of Section 2D also applies here.

## SECTION 3A – PUMP SPECIFICATION

### 3.1 HAZARDOUS AREA APPLIANCES

1. Whilst most foul-only sewage pumping stations are expected to come into the non-hazardous category, if the Scottish Water hazardous area risk assessment process (see 2.26.3) identifies any hazardous areas classified as Zone 1 or 2, all electrical and mechanical equipment shall be selected in accordance with the relevant parts of BS EN 60079 and BS EN 13463.
2. All electrical and mechanical equipment selected for use in a hazardous area shall have undergone an appropriate conformity assessment procedure to demonstrate compliance with the essential health and safety requirements of European Directive 94/9/EC (ATEX 95), as enacted in the UK by the Equipment and Protective Systems Intended for Use in Potentially Explosive Atmospheres Regulations 1996 and the Equipment and Protective Systems Intended for Use in Potentially Explosive Atmospheres (Amendment) Regulations 2001.
3. Appropriate certification shall be included in the pumping station O&M manuals to confirm the suitability of the electrical and mechanical equipment for operation in the specified hazardous area(s). Risk assessments shall be carried out in accordance with BS EN 1127-1 Explosive Atmospheres. Explosion Prevention and Protection. Basic Concepts and Methodology and any requirements from Scottish Water. Any certification, manuals, etc., shall be in accordance with Scottish Water's requirements.

### 3.2 PUMP UNIT SPECIFICATION

#### 3.2.1 Introduction

1. The pumping station shall incorporate two identical submersible pump units arranged in a duty/standby assist configuration. Each pump unit shall be capable of meeting the full design duty flow. The pump controller shall be programmable to allow Scottish Water to select how the pumps shall operate with respect to duty pump changeover, parallel pump operation, etc.
2. The pump units shall be single-stage, centrifugal, volute type, suitable for pumping untreated sewage containing fibrous material (rags, paper, etc.), solid faecal matter and grit.
3. The pump units shall comply with all relevant Statutory Regulations, and the latest editions of all relevant British and harmonised European and International Standards.
4. The pump units shall be suitable for reverse operation for short intervals of time without detriment to the impeller securing arrangements or mechanical seals.
5. To meet the requirements of Scottish Water's maintenance and efficiency initiatives, pump units shall be of a type and quality acceptable to Scottish Water. Developers shall consult Scottish Water before installing pump units to ensure acceptability.

#### 3.2.2 Performance Requirements and Information

1. Wherever possible, the maximum operating speed of the pump units shall not exceed 1500 rpm. Where a higher operating speed is necessary, e.g., due to exceptionally high static head conditions, hydraulic design evidence and life cycle cost comparison shall be provided to justify the selection of higher speed pumps.

Note: The evidence to justify the selection of higher speed pump units shall be provided prior to their purchase.

2. Each pump unit shall be capable of pumping the optimum design pumped flow rate when the sewage level is at the mid-point of the start and stop levels in the wet well.
3. The stop level for each pump unit shall be above both the vortex formation level and above the top of the motor to ensure adequate cooling of the motor and promote longevity of the pump life.
4. The pump units shall be capable of continuous operation within the design operating envelope including, where appropriate and in accordance with any hazardous area rating, being run on a regular basis for short periods of time “on snore” to keep the wet well free from silt.
5. The pump units shall have stable head versus flow rate characteristics against the system curve(s) i.e., each pump unit’s head versus flow rate curve shall slope upwards towards closed valve with reducing flow rate in one continuous curve with no points of inflection capable of causing hunting.
6. The pump units shall be selected such that the discharge flow rate is between 80% and 105% of the pump unit best efficiency point (BEP) flow rate.
7. The pump units shall be capable of discharging into an empty main.
8. The pump units shall be capable of operating against a closed valve for a short period of time.
9. The maximum diameter of solid sphere able to be passed by the pump units shall generally be in accordance with the guidelines given in Table 7.

Note: Where the pump units feature an innovative design which does not allow compliance with Table 7, substantiating information shall be provided for approval to Scottish Water prior to purchase of the pump units, to demonstrate that the solids handling performance of the pump units will satisfy the relevant requirements (i.e., the pump units will be capable of prolonged, reliable and trouble-free operation).

**Table 7 Solids Handling Performance**

Nominal Bore of Outlet (mm)	Diameter of Solid Sphere Able to be Passed (mm)	
	Type 3 Pumping Stations	Type 1 and 2 Pumping Stations
80	60	60
> 80 but < 100	75	65
>100 but < 125	90	90
> 125 but < 175	120	120

10. The pump units shall be reliable, efficient and capable of operating between the manufacturer’s recommended service intervals without attention or inspection. Pump units shall have an expected design life of 20 years when maintained in accordance with the manufacturer’s recommendations.

### **3.3 DESIGN REQUIREMENTS**

#### **3.3.1 Materials Selection**

1. Pump unit materials shall be selected with reference to the operating environment, pumped liquid and expected design life. Where there is a risk of saline ingress into the wet well, the pump unit, wet well and pipework materials shall be selected to withstand the corrosive effects including of those of H<sub>2</sub>S which is a potential product of the infiltration mixing with the sewage.

2. Where surfaces may be subject to galling, materials shall be selected to minimise wear and have a minimum hardness differential of 50 HB.

### **3.3.2 External Corrosion Protection**

1. Protective coatings shall be selected with reference to the operating environment, pumped liquid and expected design life.

### **3.3.3 Noise and Vibration**

1. The night-time ambient noise level (i.e., the combined noise level from the pumping station plus the residual noise level) shall not be more than 3 dB(A) above the residual noise level (i.e., the noise level with the pumps switched off).

2. Vibration caused either by normal pump operation or by hydraulic turbulence in the pipework shall not create a nuisance to nearby property occupants. The designer shall take this into consideration when selecting the route and number of bends required for the pumping main.

### **3.3.4 Mounting Arrangements**

1. This discharge pipework for each pump unit shall be fixed to the base of the wet well by an auto-coupling "duckfoot" adaptor. Each pump unit shall be supported from, and automatically coupled to, the outlet pipework by its own weight.

### **3.3.5 Guide System**

1. Each pump unit shall be positively guided during installation and removal operations.

2. The guide system shall be designed and installed to ensure straight, vertical lifting/lowering of the pump units.

3. The guide system shall allow the pump units to be raised to the top of the wet well without the need to undo any fixing arrangements or enter the wet well.

4. The guide system shall comprise twin circular cross-section tubes and all necessary fixtures and fixings. Guide wires shall not be used.

5. All guide tubes, brackets and fasteners (i.e., nuts, bolts, etc.) shall be made from stainless steel number 1.4401 to BS EN 10088-1. In addition, stainless steel number 1.4401 to BS EN 10088-1 hooks shall be provided alongside the top of the guide tube(s) for securing the cable support sleeves and for parking the easy-lift blue rope connection.

6. The guide tubes shall be of single-piece construction up to five metres maximum length. Above five meters, guide rails shall be supported along their length by suitably-designed brackets installed or near the mid-point of the overall length. The maximum length of any unsupported guide tube span shall be 5 m. The tops of the guide tubes shall finish a maximum of 150 mm below the underside of the wet well cover.

### **3.3.6 Pump Casings**

1. Casings shall be manufactured from grey cast iron and shall be capable of withstanding any pressure or dynamic loading that may be generated during normal pump operation including intermittent physical shock loadings caused by solids in the flow.

2. All casing surfaces having a fine clearance between fixed and rotating components shall be provided with sacrificial or renewable wear parts that are easily removable for refurbishment or replacement.



3. The outlet connection of each pump unit casing shall terminate with flange-type PN16 (minimum), in accordance with BS EN 1092-2.

4. The PN16 outlet flange of the pump casing shall be bolted to a guide rail adapter that shall incorporate a seal for sealing to the permanently installed "duckfoot" type pipework. The seal shall be installed/removed with the pump and replaceable at ground level, i.e., without the need to enter the wet well.

5. The direction of rotation of the impeller shall be clearly and indelibly marked on the pump casing with an arrow.

### **3.3.7 Impellers**

1. Impellers shall be selected to prevent fouling, allow the passage of fibrous and solid materials, and suit the operating conditions in an efficient manner.

2. Impellers shall be one-piece castings.

3. Impellers shall not be pinned or screwed to shafts, nor shall shaft rotation be relied upon to ensure that impellers are locked in position. Impellers shall be capable of running in the reverse direction (e.g., under de-ragging control).

4. To achieve acceptable vibration performance, impellers shall be balanced. Multi-vane and vortex impellers shall be balanced to a minimum of balance grade G6.3 or BS ISO 1940-1 (balancing shall be achieved by machining, not addition of weights).

### **3.3.8 Macerator Type Pumpset**

1. For Type 1 and Type 2 pumping stations, the use of macerator type pumps may only be considered where life cycle cost analysis shows this to be a cost-effective option. All macerator pump proposals shall be agreed with Scottish Water at the design stage.

### **3.3.9 Shafts**

1. Pump shafts shall be sized to accommodate all possible loads over the operating range of the pump, including starting direct-on-line (DOL).

2. The first critical speed of the rotating elements (i.e., the shaft, motor rotor and impeller) shall be at least 25% above the maximum operating speed.

3. The shaft stiffness shall be such that, under the most severe conditions of operation, the total shaft deflection at the seals does not exceed the seal manufacturer's specified tolerances.

4. The shaft shall be manufactured from a corrosion-resistant stainless steel or fitted with a corrosion-resistant stainless steel sleeve where the shaft is in contact with the pumped sewage.

5. Shaft sleeves (where provided) shall:

- a) not cause galvanic corrosion between the sleeve and the shaft;
- b) be positively driven (i.e., keyed or pinned to the shaft); and
- c) incorporate O-ring seals to prevent leakage of the pumped sewage between shafts and sleeves.

### **3.3.10 Seals**

1. Sealing between the casing volute and motor enclosure shall be achieved by primary (casing volute to buffer chamber) and secondary (buffer chamber to motor enclosure) mechanical seals and by a fluid-filled chamber between the primary and secondary seals.

2. Stationary and rotating rings shall be composed of a single material, i.e., wear-resistant coatings shall not be used.
3. Seal component materials shall be compatible with the pumped sewage.

### **3.3.11 Bearings and Bearing Lubrication**

1. Rotating assemblies (motor rotor, shaft and impeller) shall be supported by sealed-for-life, grease-lubricated upper and lower rolling element bearings.
2. Bearings shall be rated for a minimum  $L_{10h}$  life of 50,000 hours at the design operating conditions.

### **3.3.12 Information Plate**

1. Each pump unit shall be provided with an information plate, permanently fixed to the pump unit. The plate and its fixings shall be manufactured from corrosion-resistant metallic materials. As a minimum, the information plate shall include the following information:

- a) pump unit manufacturer;
- b) pump unit type;
- c) pump unit serial number;
- d) impeller number or diameter;
- e) flow rate at the duty point (l/s);
- f) head at the duty point (m);
- g) operating speed (rpm);
- h) motor rating (kW);
- i) operating voltage (V), number of phases and frequency (Hz);
- j) full load current (A);
- k) full load power factor;
- l) insulation class;
- m) enclosure classification (IP rating);
- n) hazardous area classification; and
- o) pump unit weight.

2. Duplicate information plates shall be provided and labelled "Pump No.1" and "Pump No.2". These shall be positioned adjacent to the electrical assembly in a clearly-visible location.

### **3.3.13 Pump Unit Lifting Points**

1. Each pump unit shall be provided with clearly-identified, permanent, corrosion-resistant lifting points, located to give a safe, balanced lift.
2. Lifting points shall be designed for lifting the whole pump unit.
3. The pump unit shall incorporate a lifting handle. The handle shall be made from stainless steel number 1.4401 to BS EN 10088-1. If the handle is not an integral part of the pump casing, it shall be secured to the pump casing using fasteners manufactured from stainless steel number 1.4401 to BS EN 10088-1 and be provided with suitable galvanic isolation.

### **3.3.14 Pump Unit Cables**

1. Each pump unit shall be supplied and fitted with a cable of a suitable length to reach the means of termination which shall be one of the following:

- a) the kiosk MCC gland plate and terminals;
- b) an intermediate junction box in the valve chamber;
- c) an inline plug and socket connector suspended in the wet well.

2. Where plug and socket connectors are provided, they shall be supplied with two retained caps for protection of the plug and socket when disconnected and shall be suitable for termination of the wires by crimping. Plug and socket connectors shall be installed in a slack loop of cable between the cable support bracket and the cable duct such that the plug and socket can be lifted above ground level to facilitate safe connection and disconnection.

3. If the wet well and valve chamber have been designated as hazardous areas, all equipment installed in these areas shall be rated and certified accordingly for installation in hazardous areas.

4. Cables shall be securely anchored inside the wet well. The method of securing the cables shall avoid excessive stressing of the cables and allow the pump units to be withdrawn from the wet well without fouling the cables. The anchor shall be capable of ready release.

### **3.3.15 Pump Unit Protection Sensors**

1. The pump units shall be equipped with protection sensors for preventing overheating of the motor winding insulation (this shall be achieved by at least two thermal switches embedded in the stator winding coils).

2. Pump units shall be equipped with moisture detection sensors for detecting seal wear and seal leakage.

### **3.3.16 Pump Unit Lifting Arrangements**

#### **3.3.16.1 General**

1. All lifting equipment (including attachments for anchoring, fixing or supporting the lifting equipment) and lifting accessories (chains, eyebolts, etc.) shall comply with the Lifting Operations and Lifting Equipment Regulations (LOLER) 1998 and the Provision and Use of Work Equipment Regulations (PUWER) 1998.

2. All lifting equipment and lifting accessories shall be visibly and indelibly marked (i.e., stamped or painted with the following:

- a) their safe working loads (SWL);
- b) the lifting equipment/accessory serial number; and
- c) the date of the next "thorough" examination of the lifting equipment/accessory, in accordance with LOLER. This date will change on a regular basis and so shall be indelibly marked on a replaceable component located within the kiosk and secured to the relevant pump unit door using a cable tie.

3. The following information shall be provided in relation to all lifting equipment and lifting accessories:

- a) the original test certificate;
- b) an EC "Declaration of Conformity", from the lifting equipment/accessory manufacturer; and
- c) a "Report of Thorough Examination", in accordance with LOLER. If, at the time of adoption of the pumping station, there is less than six months from the date of the "Report of Thorough Examination" until the next inspection, then a further examination shall be undertaken by the developer.

All of the above information shall be in accordance with Scottish Water's requirements and copies shall be inserted in the pumping station O&M manuals.

4. Pump units shall be provided with a Scottish Water approved specification lifting chain for utilisation with the blue rope system and pump chain lifting adapter location system if all of the following criteria are satisfied:

- a) the wet well is less than or equal to 6 m in depth;
- b) the weight of each pump unit is less than or equal to 400 kg; and
- c) the pump unit lifting handle is of a suitable design to accept Scottish Water's standard lifting chain and shackle.

5. If any of the above criteria are not satisfied, Scottish Water shall be consulted regarding lifting requirements.

### **3.3.16.2 Lifting Chains Location System**

1. Lifting chains shall be 1 m length of Scottish Water specification short-link Grade 50 AISI316 stainless steel pump lifting chain c/w transition links each end and fitted with stainless steel Dee shackle Grade 50 AISI316. The minimum safe working load of the lifting chain assembly shall be 1 tonne. Lifting chains shall be in accordance with the Scottish Water Approved Written Scheme of Examination.

2. The pump unit shall be extracted from the wet well by using a certified chain lifting adaptor to catch the 1 m chain.

## **3.4 TESTING**

### **3.4.1 General**

1. The pump units shall be tested at the manufacturer's premises for noise and vibration, temperature, leakage, seals and flow/head/power. Pumps shall be tested to at least BS EN ISO 9906 Grade 2 Annex A.1 to demonstrate that they are capable of achieving the specified design duty. Type-test curves are acceptable for verification of performance.

2. Characteristic curves of pump total differential head, pump efficiency, pump power input and motor power input versus flow rate shall be submitted to Scottish Water before the pump units are delivered to site.

3. The pump curve plotted against system curve shall be supplied in a laminated form and fixed to the inner door of the kiosk.

### **3.4.2 Testing On Site**

1. The pump units shall be tested on site to ensure they are capable of delivering the design flow rate under all possible operating conditions, without cavitation or excessive noise, vibration, temperature or leakage.

2. To this end, hydraulic drop tests shall be carried out by the developer in the presence of Scottish Water to verify the theoretical performance of each pump unit. The results of these tests shall be recorded and placed in the O&M manuals. The accuracy of the drop test shall be within  $\pm 7\%$  on head and flow. The accuracy of flow meter readings (where fitted) shall be demonstrated by comparing them to the drop test results.

3. A visual inspection of the pumping station shall be made to ensure it complies with this Specification. The wet well shall be checked for signs of stagnation, vortices, pre-swirl and accumulation of solids. Functional checks shall be made of all installed instrumentation, level settings, etc. These checks shall be made in the presence of Scottish Water.

### **3.4.3 Ancillary Items**

Prior to vesting, the developer shall hand over the following items to Scottish Water:

- a) critical spare parts - all critical spare parts as required to ensure two years of operation of the pumping plant and control equipment;
- b) access cover lifting keys/irons – two sets;
- c) access cover locking keys - three complete sets;
- d) kiosk keys - three complete sets;
- e) control panel keys - three complete sets;
- f) telemetry key-switch key - three copies.

The pumping station shall not be vested until all of the above items have been received.

# SECTION 3B – MOTOR SPECIFICATION

## 3.5 INTRODUCTION

1. This Specification defines the requirements for motors forming part of submersible pumpsets for use by Scottish Water.
2. The motor shall comply with all relevant Statutory Regulations and the latest editions of all relevant British and harmonised European Standards, including, but not limited to:
  - a) BS EN/IEC 60034 – 1, 2, 5, 6, 7, 8, 9, 11, 14 and 30 Rotating electrical machines;
  - b) BS EN 60204 - Safety of machinery. Electrical equipment of machines; and
  - c) BS 4999 – 141 and 145 General requirements for rotating electrical machines.
3. The motor shall also comply with:
  - a) this Specification; and
  - b) any WIMES 3.03 documentation issued by, or on behalf of, Scottish Water in respect of the motor.
4. Where the documentation referenced in 3.5.3 of this Specification imposes additional requirements to a British or harmonised European or International Standard, the requirements of the documentation referenced in 3.5.3 of this Specification shall prevail.
5. The supplier shall operate an approved, auditable quality assurance procedure covering the design, manufacture and works testing of the motor.

## 3.6 PERFORMANCE REQUIREMENTS

1. Motors shall be capable of continuous operation under the operating conditions of the pumpset.
2. Motors shall be suitable for a 400 V, 3-phase, 3-wire, earthed neutral, 50 Hz supply. Tolerances on the supply shall be  $\pm 10\%$  on voltage and  $\pm 1\%$  on frequency.
3. Each motor shall have a maximum continuous (MC) rating, based on duty type S1 (as defined in BS EN 60034-1), equal to at least 110% of the maximum load (absorbed power) of the pumpset over its operating range.
4. Motors shall be capable of withstanding fifteen equally-spaced starts per hour without overheating or causing detriment to the windings or insulation.
5. Attention is drawn to the requirements of The Ecodesign for Energy-Using Products Regulations 2007 (as amended), these are summarised in Table 8.

**Table 8 Motor Efficiency Requirements**

<b>Installation Date</b>	<b>Requirement</b>
	<b>Motors with Fixed Speed Drives</b>
Prior to 1 <sup>st</sup> January 2015	Motors shall meet the IE2 efficiency level
Between 1 <sup>st</sup> January 2015 and 31 <sup>st</sup> December 2016	Motors with a rated output of $\geq 7.5$ kW shall meet the IE3 efficiency level, other motors shall meet the IE2 efficiency level
After 1 <sup>st</sup> January 2017	Motors with a rated output of $\geq 0.75$ kW shall meet the IE3 efficiency level, other motors shall meet the IE2 efficiency level
Note: IE2 and IE3 efficiency levels are defined IEC-60034-30	

### **3.7 DESIGN REQUIREMENTS**

1. Motors shall have an enclosure classification of IP68 in accordance with BS EN 60529 and be suitable for operation whilst continuously submerged to a minimum depth of 10 m (or more to suit the depth of wet well).
2. The maximum ambient temperature of the operating environment shall be assumed to be 40°C. The motor insulation class, in accordance with BS EN 60085, shall be at least one class higher than the temperature rise limit, in accordance with BS EN 60034-1 as measured by the resistance of the windings during full-load operation, subject to a minimum insulation class of Class F.
3. The direction of rotation shall be clockwise (viewed from the drive end) when the motor is connected to a 3-phase supply of BBG (brown, black, grey) anti-clockwise phase rotation, with the BBG (brown, black, grey) phases connected to the L1/L2/L3 terminals, respectively.
4. Each pump unit shall be supplied and fitted with a cable of a suitable length to be supported by the cable support system in Clause 3.2.17.4 and to reach the termination point without stretching or subjecting the cable to unnecessary strain.
5. Cables shall be suitably-rated for the duty, be constructed in accordance with BS EN 50525 with oil- and weather-resistant chloroprene rubber (or equivalent) sheathing and comprise power and auxiliary cables necessary for the motor supply and all protection circuits.
6. Each cable shall incorporate an earth conductor.
7. For wet well submersible type installations, each pump unit cable shall be connected to its associated control panel cable using one of the following:
  - a) for hazardous area connection:
    - An approved (Eex “N” II T6, in-line) in-line multi-pin plug and socket connector certified for installation in the specific classification of hazardous area; or
    - A separate junction box (fitted with barriers for segregating cables with different operating voltages) for each pump unit suitable for installation in the specific classification of hazardous area and installed above the maximum flood level in the valve chamber.
  - b) for non-hazardous area connection:
    - An approved IP68 multi-pin plug and socket connector for installation in non-hazardous areas; or
    - A separate junction box (fitted with barriers for segregating cables with different operating voltages) for each pump unit of minimum IP55 rating and installed above the maximum flood level in the valve chamber in an accessible position.

8. Plug and socket connectors shall be installed in a suspended loop of cable that can be lifted above ground level for connection and disconnection. All plug and socket connectors shall be supplied with retained caps for protection of the plug and socket when disconnected.

### **3.8 METHODS OF PROTECTION FOR ELECTRICAL EQUIPMENT IN HAZARDOUS AREAS**

1. If, as determined in the DSEAR risk assessment, the pump unit will operate in a hazardous area classified as Zone 1 or 2, all electrical equipment (motors, cables, etc.) shall be selected in accordance with the relevant parts of BS EN 60079-14.

2. The motor construction, testing and marking shall comply with BS EN 60079, as modified by BS EN 60079-1 for motor protection type "d" (flameproof) or BS EN 60079-7 for motor protection type "e" (increased safety).

3. Cables and connectors shall be selected in accordance with BS EN 60079-14.

4. In addition to the electrical equipment requirements, there will be a requirement to certify all mechanical equipment installed in hazardous areas as being suitable for operation in these areas.

5. Appropriate certification shall be included in the O&M manuals to confirm the suitability of the electrical and mechanical equipment for operation in the specified hazardous area(s).



# SECTION 3C – ELECTRICAL SPECIFICATION

## 3.9 SCOPE

1. Where a pumping station is deemed to have a high risk of blockage, when assessed in accordance with Section 2.26.2 and requires blockage prevention technology, the electrical assembly shall comply with the SW Specifications for Wastewater Pumping Stations and Intelligent Pumping Station Controllers (IPSCs) or else be selected from the range of Scottish Water Standard Products. Direct-On-Line Reversing (DOLR) starters shall only be used for motors  $\leq 7.5\text{kW}$  and Variable Speed Drive starters shall be used for motors  $>7.5\text{kW}$ .

2. Where a pumping station is deemed to have a low risk of blockage, when assessed in accordance with Section 2.26.2, the electrical assembly shall be in accordance with Sections 3.9 to 3.12.

This electrical equipment shall typically comprise:

- a) an incoming power supply;
- b) a low voltage switchgear and control gear assembly (hereafter termed "electrical assembly") incorporating the incomer, motor starters, control circuit supplies, common control equipment and interface for connection to the telemetry outstation;
- c) the pumping station electrical installation, incorporating all electrical components, equipment and cabling outside the electrical assembly, and the pumping station earthing and bonding system;
- d) instruments associated with the pumping station including the ultrasonic transducer head, float switches, and flowmeter (if required); and
- e) a telemetry outstation with appropriate communications connection (e.g., GSM, PSTN, radio link, satellite, etc.).

## 3.10 GENERAL

### 3.10.1 General

1. The incoming electricity supply to the pumping station shall be 400 V, 3-phase and neutral, 4-wire, 50 Hz.

2. The developer shall obtain an Application to Connect form from the distribution network operator (DNO). This shall be completed and signed by the developer and submitted to the DNO when the installation is ready for connection to the DNO's supply. Before the form is sent to the DNO, it shall be submitted to Scottish Water so that the tariff agreement can be checked, etc.

3. The pumping station shall comply with the requirements of the DNO. These requirements include, but are not limited to, maximum demand, motor starting and/or stopping, harmonic contribution and electromagnetic interference limits, fault discrimination and isolation requirements.

4. Either "direct-on-line" or "star/delta" motor starting shall be provided, depending upon the limitations of the local electricity supply. The developer shall obtain DNO approval to the starting arrangements.

5. The pumping station shall be suitable for use by electrically-instructed persons as defined in BS 7671.

6. All electrical installation work shall either be carried out by a contractor registered by the National Inspection Council for Electrical Installation Contracting (NICEIC) or, with the written approval of Scottish Water, by an unregistered contractor. In the latter case, an inspection and written report by

a NICEIC-registered contractor will be required on the appropriate NICEIC form. The developer shall pay for this inspection and carry out, at his own cost, any modifications recommended therein.

7. On completion of the electrical installation, the developer shall carry out the following tests:

- a) all relevant tests specified in BS 7671, with particular reference to 'IET Guidance Note 3: Inspection and Testing'; and
- b) functional tests of control circuitry under normal and abnormal conditions to confirm that the pumping station operates in accordance with the schematic diagrams and the required control philosophy.

8. Following the satisfactory completion of tests, the developer shall provide Scottish Water with:

- a) an Electrical Installation Certificate, as required by BS 7671;
- b) a copy of the test schedule relating to 3.10.1.7a) and 3.10.1.7b) above, detailing the times and dates when all tests were performed, and the test results obtained;
- c) a signed declaration that the pumping station operates in accordance with the schematic diagrams and the required control philosophy;
- d) a label on the front of the incoming section of the electrical assembly indicating the test date.

### **3.10.2 Labels and Safety Signs**

#### **3.10.2.1 General**

1. Labels and safety signs shall be written in English and be unambiguous, durable and legible. Labels shall be attached directly on or adjacent to, the electrical equipment to which they refer, but not to trunking covers or other easily-removable or transferable items.

2. Labels shall be attached using an appropriate number of corrosion-resistant mechanical fixings. Self-adhesive plastic tape or glue shall not be used to attach labels.

3. The fixing of labels, safety signs and notices shall not affect the IP rating of the electrical equipment.

#### **3.10.2.2 Labels**

1. Labels mounted on the outside of an enclosure (e.g., control panel, junction box, local control station, etc.) shall be manufactured from laminated plastic and engraved so as to produce black letters on a white background. Labels mounted on the inside of an enclosure shall be to the same standard, or alternatively, may be printed using an approved proprietary system. Characters shall be upper case and for:

- a) application labels be not less than 6 mm in height;
- b) designation labels be not less than 4 mm in height;
- c) component identification labels be not less than 3 mm in height.

2. Internal components shall be clearly identified by individual labels and have circuit designations which correlate with the installation drawings and documentation. Where this is not practical due to space restrictions, common labels (e.g., laminated diagrams) may be used. Fuse labels shall detail the fuse rating.

#### **3.10.2.3 Safety Signs**

1. The lettering, colour and layout of safety signs shall comply with BS EN ISO 7010 and the Health and Safety (Safety Signs and Signals) Regulations 1996. Hazardous area signs shall be installed in accordance with the Dangerous Substances and Explosive Atmospheres Regulations 2002 (DSEAR).

2. Safety signs shall be provided to warn of danger to personnel and to provide compliance with BS 7671 and Statutory Regulations. As a minimum, safety signs shall be fitted to removable covers over busbars and live connections, and to doors of compartments containing:

- a) incoming supply cable termination points;
- b) incoming supply switching and isolation devices;
- c) an internal switching and isolation device;
- d) more than one supply or multiple control circuits originating elsewhere;
- e) equipment located within a “safe area” but associated with certified apparatus located within a hazardous area. A sign shall also be fitted at the safe area cable termination rail;
- f) voltages greater than or equal to 50 V, where such voltages would not be expected.

3. Self-adhesive, vinyl safety signs may be used.

### **3.10.3 Operation and Maintenance Documentation**

1. Operation and maintenance documentation shall be provided in accordance with the requirements of Scottish Water.

## **3.11 THE ELECTRICAL ASSEMBLY**

### **3.11.1 General**

Note: Throughout Section 3.11 to 3.13 of this Specification, the use of the term “enclosure” is intended to mean the electrical assembly for Form 1 assemblies or the compartment for Form 4 assemblies.

1. The control panel shall be manufactured, tested, certified and CE marked by the manufacturer before delivery. Appropriate reference to the relevant EU Directive (Low Voltage and/or Electromagnetic Compatibility (EMC) Directives) shall be provided adjacent to the CE mark.

2. Where the motors are rated less than or equal to 5.5 kW and a minimum of one hour of wastewater storage is provided in the system to allow for routine maintenance, without the system overflowing or localised flooding occurring, the control panel shall be Form 1 with bottom cable entry.

3. Where the motors are rated at more than 5.5 kW or the wastewater storage provided is less than one hour, the control panel shall be Form 4 with bottom cable entry.

Note: There are minor differences in the number and type of front of panel equipment fitted to the Form 1 and Form 4 control panels. Procurement of the control panel through a Scottish Water MCC framework supplier would ensure compliance with these requirements.

4. When the control panel is isolated and open, the degree of ingress protection (IP rating) of any remaining live part, or of any part which could be energised at above extra-low voltage during any test procedure, shall be a minimum of IP2X.

5. Suitably-rated protection devices shall be provided at all points necessary for the protection and isolation of power and control circuits, and to minimise disruption to the overall system on the failure of a component part of the system.

6. Compartments that contain both extra-low and low-voltage systems shall be arranged so that systems of differing voltages are physically segregated from each other.

7. All electrical components shall comply with BS EN 60947-1 to 7 as applicable.

### 3.11.2 Design Verification

1. The electrical assembly shall be subject to a process of design verification to ensure compliance with the relevant parts of BS EN 61439-2.

2. Design verification shall comprise the following constructional and performance requirements:

Constructional requirements:

- a) strength of materials and parts;
- b) degree of protection of enclosures;
- c) clearances and creepage distances;
- d) protection against electric shock and integrity of protective devices;
- e) incorporation of switching devices and components;
- f) internal electrical circuits and connections;
- g) terminals for external conductors.

Performance requirements:

- a) dielectric properties;
- b) temperature rise;
- c) electromagnetic compatibility;
- d) mechanical operation.

3. Design verification shall be achieved by the application of one or more of the following methods, as appropriate:

- a) testing;
- b) calculation;
- c) physical measurement;
- d) validation of design rules.

4. All data used, calculations made and comparisons undertaken during the design verification process shall be recorded by the electrical assembly manufacturer and made available to Scottish Water on request.

### 3.11.3 Construction

#### 3.11.3.1 General

1. The electrical assembly shall comprise an “enclosed assembly” of the cubicle type, as defined in BS EN 61439-1.

2. The IP rating of the electrical assembly shall be IP54. This IP rating shall apply to the complete assembly including all components mounted on the assembly.

3. The electrical assembly shall be constructed from materials capable of withstanding the mechanical, electrical, thermal and environmental stresses to which it may be subjected, and the environmental and operating conditions likely to be encountered in normal service.

4. Protection against corrosion shall be ensured by the use of suitable materials or by the application of protective coatings, taking into account the intended conditions of use.

5. The electrical assembly, including doors and covers, shall be suitably braced to produce a rigid structure. For steel assemblies, the minimum thickness of steel shall be 2 mm.

#### 3.11.3.2 Cable Entry, Cableways and Gland Plates

1. The electrical assembly shall be designed for bottom entry of the pump cables.

2. Cableways shall have sufficient space to enable the installation and removal of any cable without the need to remove any other cable or component. Cableways shall incorporate adequate facilities to locate and support the cables.

3. Gland plates shall be rigidly supported and maintain the IP rating of the enclosure.

4. Each gland plate shall be an integral part of the construction of its associated enclosure, i.e., it shall not be mounted on a bracket within that enclosure.

### **3.11.3.3 Installation and Layout of Components**

1. Control gear, terminals, labels and wiring within a given enclosure shall be arranged so that each component can be identified, inspected, maintained, removed and replaced from the front of the electrical assembly without the need to enter any other enclosure and without moving or dismantling any other component or wiring.

2. If a special tool is necessary to remove a component, the tool shall be supplied with the assembly.

3. Fixings for internal components and component mounting plates shall not penetrate the side plates of the assembly or the boundary of an adjacent enclosure. If self-tapping screws are used for component fixing, they shall be of the thread-forming or thread-rolling type.

### **3.11.3.4 Doors**

1. Doors shall be adequately sized and braced to accommodate all door-mounted components and labels.

2. Doors shall have vertical hinges providing an angle of opening of at least 95°.

3. Doors shall have the requisite number of handles to ensure effective opening and closing, and shall require a tool for opening.

4. Doors shall be restrained in the open position by either an integral facility in the hinge/door design or by a restrainer. Electrical braid or cable and crimped electrical lugs shall not be used as restrainers.

## **3.11.4 Earthing and Bonding**

### **3.11.4.1 General**

1. The assembly earthing system shall incorporate an earth bar or main earth stud. The earth bar or stud shall be provided with facilities for connecting to the main earth terminal (MET) provided by the DNO.

2. Each metal gland plate shall be connected directly to the earth bar or stud by a separate protective conductor. Protective conductors shall be sized to withstand the fault level, subject to a minimum cross-sectional area (CSA) of 6 mm<sup>2</sup>.

3. Separate earth bars or studs shall be provided for connecting equipment requiring a clean earth or an intrinsically-safe earth directly to the MET. If required, such earth bars or studs shall be located adjacent to the equipment requiring a clean earth or an intrinsically-safe earth, as appropriate.

4. Self-tapping or self-forming screws and push-on type connections shall not be used for earth connections. All earth connections shall utilise bolt or stud and nut connections with shake-proof washers.

5. The earth bar or stud shall be located in the cable marshalling compartment.

### 3.11.4.2 Form 4 Electrical Assemblies

1. Each compartment shall include an earth stud, connected to the earth bar or main earth stud by a separate protective conductor. Protective conductors shall be sized to withstand the fault level, subject to a minimum CSA of 6 mm<sup>2</sup>.
2. Each compartment shall have protective conductors, with a minimum CSA of 2.5 mm<sup>2</sup>, or braided straps of the appropriate CSA for earthing and EMC requirements, taken from the compartment earth stud to the following:
  - a) the compartment door;
  - b) component mounting plates and earth terminals;
  - c) equipment mounting rail earth terminals; and
  - d) the metal cases of instruments.

### 3.11.4.3 Form 1 Electrical Assemblies

1. The assembly shall have protective conductors, with a minimum CSA of 2.5 mm<sup>2</sup>, or braided straps of the appropriate CSA for earthing and EMC requirements, taken from the electrical assembly earth bar or stud to the following:
  - a) the assembly door;
  - b) component mounting plates and earth terminals;
  - c) equipment mounting rail earth terminals; and
  - d) the metal cases of instruments.

## 3.11.5 Cabling and Wiring

### 3.11.5.1 General

1. Single core wiring shall comply with BS 6231 and have a minimum CSA of 0.75 mm<sup>2</sup>. Multi-core cables shall comply with BS EN 50525 and have a minimum CSA of 1.0 mm<sup>2</sup>. Electronic equipment wiring shall have a minimum CSA of 0.22 mm<sup>2</sup>. Conductors shall be stranded or flexible copper.
2. Analogue signal cabling shall comprise screened cables (individually and/or collectively screened) and/or twisted pairs.
3. Neutral conductors shall have the same CSA as their associated line conductors.
4. If ribbon cable, small cross-section wiring or multi-pin plug and socket arrangements are fitted to proprietary components, a terminal rail shall be installed adjacent to the proprietary component for conversion to conventional assembly wiring.

### 3.11.5.2 Installation

1. Wiring shall:
  - a) be installed in a neat and systematic manner;
  - b) be loomed together or enclosed in non-metallic trunking. Trunking covers shall be unobstructed and easily accessible to facilitate future removal and replacement. They shall face either the side or front of the enclosure but not the rear; and
  - c) run to enclosure doors in spirally-wrapped protection or similar. The spacing of intermediate adhesive fixings shall ensure that fixings are not likely to become detached during service.
2. Wires shall enter and leave an enclosure via a terminal rail and shall not be joined between terminals. Permanently-fixed insulating bushes shall be provided where wiring passes through internal plates or partitions.

3. Plastic wiring accessories including cleats, conduits and strapping shall be suitable for their operating environment and shall not degrade prematurely. Self-adhesive wiring clips shall not be used.

4. Different categories of cabling and wiring shall be installed so as to prevent interference with each other. The following requirements shall apply as a minimum:

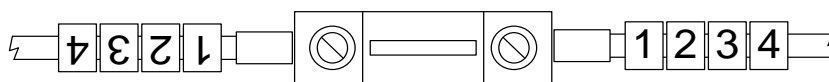
- a) cabling and wiring associated with intrinsically-safe circuits (IS) shall be segregated from other circuits in accordance with BS EN 60079-14. IS circuit trunking shall be appropriately labelled with no other circuits enclosed within it; and
- b) if lightning and/or surge protection measures have been used to protect individual circuits, these circuits shall be segregated from the wiring of other unprotected circuits.

### 3.11.5.3 Identification of Wiring

1. All cabling and wiring shall be identified at both ends by interlocking ferrules, heat-shrink identification (HSI) or any other system approved by Scottish Water, in accordance with the schematic diagrams for the electrical assembly.

2. The wiring identification system shall be the correct size for the wiring, clearly visible and accessible where the wire enters the terminal and shall read "outward" from the terminal (see Figure 28 below).

**Figure 28 Identification of Wiring**



3. All spare cores shall be identified.

4. The colour code for wiring shall be in accordance with Table 9.

**Table 9 Colour Code for Wiring**

Function	Colour
Protective conductor	Green and Yellow
Current transformer (CT) circuits	White
<b>Power Circuits</b>	
Phase of a single phase circuit	Brown <sup>(4)</sup>
Phase 1 of a three-phase AC circuit	Brown <sup>(3)</sup>
Phase 2 of a three-phase AC circuit	Black <sup>(3)</sup>
Phase 3 of a three-phase AC circuit	Grey <sup>(3)</sup>
Neutral of a single- or three-phase circuit	Blue
<b>Control Circuits</b>	
110 V ac	Red
24 V ac	Yellow
24 V dc	Yellow
Neutral (where required)	Blue
Inter-compartment, unsheathed	As per voltage
Inter-compartment, sheathed	Grey sheath, White cores
<b>Signal Circuits</b>	
Volt free, known voltage	As Per voltage
Volt free, unknown voltage	Red
Telemetry digital signals (single cores)	Pink <sup>(1)</sup>
Telemetry digital signals (multicore RTU-MCC)	White
Analogue 4-20 mA/1-5 V DC Single cores (multi drop applications only)	As per voltage <sup>(2)</sup>
Analogue 4-20 mA/1-5 V DC Screened (all standard applications including telemetry)	+ve – White <sup>(5)</sup> -ve – Blue <sup>(5)</sup>
Intrinsically-safe	Light Blue
Colour code notes to Table: (1) Signal and voltage/current and source/sink cabling (2) For example, 24 V applications will have Yellow(+) and Blue(-) (3) Brown may be used for all three phases, identified L1, L2 and L3 at each end of the conductor and at intervals along its length (4) If there is more than one type of single phase wiring present within the electrical assembly, the wiring shall be phase coloured (5) For example, for cables to PAS 5308-2/BS EN 50288-7, a single pair is coloured White/Blue	

### 3.11.5.4 Termination of Wiring

#### General

1. Wiring shall be terminated using insulated crimp connectors, lugs or any other approved method that is suitable for the conductor and the type of terminal. Only the crimp/lug (or equivalent)



manufacturer's recommended tools and equipment shall be used to perform the termination. All of the strands forming the conductor shall be connected at the point of termination.

2. Wiring with a CSA of less than or equal to 6 mm<sup>2</sup> shall be terminated in terminals mounted on DIN rail. Wiring with a CSA of greater than 6 mm<sup>2</sup> shall be terminated in bolted terminals.

3. Wiring shall be terminated so that all internal wiring is connected to one side of a terminal rail and all external cabling and wiring is connected to the other side of the same terminal rail.

4. No more than two conductors shall be connected to one side of a terminal.

5. Spare cores shall be terminated at both ends.

6. Groups of terminals shall be secured with an end stop at either end, which may be an earth terminal.

7. If it is necessary to use common terminals, proprietary shorting bars or combs shall be used.

8. Hinged-link type terminals shall be provided if circuit disconnection is required (e.g., for analogue signal circuits, the isolation of external control devices and for all alarm and telemetry circuits).

### **Layout and Identification of Terminals**

9. Terminals shall be positioned so that there is sufficient surround space to enable conductors to be connected without undue bending or stress. The following requirements shall apply, as a minimum:

- a) to facilitate the termination of cable cores, a minimum distance of 100 mm shall be provided between the entry point of cables into an enclosure and the associated terminals. This shall be increased, as required, for larger cables; and
- b) a minimum distance of 30 mm shall be provided between the exit point of wiring from trunking and associated terminals.

10. Terminals shall be safely and easily accessible after all wiring has been installed and terminated.

11. Terminals shall be grouped together and segregated according to operating voltage and function by terminal rail mounted barriers. Stud-type terminals shall be provided with individual segregating barriers.

12. Terminals shall face the enclosure door for ease of connection.

13. Terminals shall be positioned and uniquely identified in accordance with the schematic diagrams for the assembly and shall show the circuit wire number reference.

14. Horizontal terminals shall be numbered left to right and vertical terminals top to bottom.

15. Terminals used for the connection of intrinsically-safe circuits shall be coloured blue and be physically separated from other terminal groups by a minimum distance of 50 mm. These terminals shall have a clear shrouded cover and be fitted with an appropriate warning label.

### **Termination of Screen Signal Cables**

16. If practicable or recommended by the device manufacturer, screened signal cables shall be wired directly to and terminated at the device. If this is not practicable, the method of interface termination shall not compromise the integrity of either the conductors or screen.

17. Unless otherwise specified by the instrument manufacturer, all instrument cable screens shall be tied back and insulated from earth at the instrument end of the cable, and at the control panel end of the instrument cable the screens shall be connected to the instrument earth bar, i.e., one common star point.

18. If it is necessary to connect the screen to earth, either directly or via a capacitive coupling, a proprietary 360° connection shall be used.

19. If it is necessary to isolate the screen from earth, a suitable length of the overall sheath and the screen shall be removed and a 30 mm long silicone rubber over-sleeve shall be installed over the point of separation of conductors, screen and overall sheath.

### **3.11.6 Indicator Lamps, Push-buttons and Selector Switches**

1. Indicator lamps shall be 22 mm in diameter and be of the extra-low voltage, transformer-type with multi-cluster light emitting diodes (LEDs). Filament lamps shall not be used.

2. The indicator lamp colours shall be as follows:

- a) "Pump Unit Running" lamp – green;
- b) "Pump Unit Tripped" lamp – yellow;
- c) "Auto Available" lamp – white; and
- d) individual fault lamps – yellow.

3. Push-button switches shall comply with BS EN 60947-5-1. They shall be 22 mm in diameter, and match the indicating lamps in style.

4. The push-button switch colours shall be as follows:

- a) "Pump Unit Start" push-button – green;
- b) "Pump Unit Stop" push-button – red; and
- c) common "fault reset" push-button – black (with appropriate labelling).

5. Selector switches shall comply with BS EN 60947-5-1. They shall be of the rotary type and be spring-loaded to ensure positive operation. All switch positions shall be clearly identified.

6. All indicator lamps, push-buttons and selector switches shall incorporate a proprietary, anti-rotation feature (e.g., a locator notch or other proprietary method of fixing). Components shall not rely solely on a locking ring to prevent rotation.

### **3.11.7 Connection for a Mobile Generator**

1. A connection for a mobile generator shall be provided on the incoming section of the electrical assembly. This shall be a 125 A, 5-pole (L1, L2, L3 + N + E), male appliance inlet to BS EN 60309-2.

2. The appliance inlet shall be readily-accessible to facilitate the connection of the mobile generator cable.

### **3.11.8 Ultrasonic Level Controller (ULC) Specification**

#### **3.11.8.1 Normal Operation**

1. The automatic control sequence set out in Clauses 2 to 8 below shall be enabled for all pumps.

2. The pump units and control equipment shall be designed to operate on a fully automatic duty and standby/assist arrangement, with the start and stop duty controls being subject to pre-determined wet well levels. Each pump unit will in turn act as the duty pump after each complete "stop and start"

cycle, thus ensuring both pumps have an equal share of a normal day's pumping. Should there be an imbalance in efficiency of each pump unit, the control system shall favour the most efficient pump unit by a programmable ratio.

3. With the duty pump running, should the inflow to the wet well be in excess of the duty pump capacity, the standby/assist pump will be brought into operation automatically by the high-level control and will then operate in parallel with the duty pump until the wet well level is lowered to the common stop level.

4. Thereafter, the cycle of operation shall be repeated as determined by the wet well level/inflow.

5. Pump control levels, as measured from the bottom (zero level) of the well, shall be determined by the designer to ensure the maximum number of pump starts per hour does not exceed fifteen. The control levels shall be referred to as follows:

- a) level rising through "snore" level (L1) – no action;
- b) level rising through common pump unit stop level (L2) – no action;
- c) level rising through duty pump unit start level (L3) – start duty pump unit;
- d) level rising through assist pump unit start level (L4) - start assist pump unit (keep duty pump running);
- e) level rising through high-level pump start level (L5) – level control switches from ultrasonic level controller (ULC) to relay/timer control and starts duty pump which runs for a pre-set time. High-level alarm sent via telemetry;
- f) level rising through overflow level (L6) – overflow operating alarm sent via telemetry;
- g) level falling through assist pump unit start level (L4) – no action;
- h) level falling through duty pump unit start level (L3) – no action. Level control switches back to ULC if high-level relay control has been activated;
- i) level falling through common pump unit stop level (L2) – stop all operational pumps;
- j) level falling through "snore" level (L1) – stop operating pump and reset to normal control cycle.

6. The ULC shall be configured to initiate a wet well cleaning "snore" cycle once a day (i.e., allow the duty pump unit to "over-run"). L1 shall be chosen to be as low as possible without affecting the safe/effective operation of the pump units: the pump unit manufacturer shall be consulted to this end.

7. The ULC shall be configured so that the wet well level readings are displayed (and/or, if required, transmitted via telemetry) in metres.

8. The ULC shall be configured so that the "zero level" reading in the wet well corresponds to L1, i.e., the level below which the pump units cannot pump anymore.

### **3.11.8.2 Features**

1. The ULC shall incorporate a number of relays (minimum of five) to operate the pump units and alarms according to the required control philosophy.

2. The ULC shall incorporate a 4-20 mA output (typically used for remote wet well level monitoring via telemetry).

3. The ULC shall incorporate a number of digital inputs.

4. The ULC shall incorporate a clear visual display of settings/parameters and conditions using standard engineering units. The display shall be visible during times of low light (e.g., by means of a back light).

5. The ULC shall be capable of communication with the upstream telemetry outstation through either a hard-wired connection or serial data communications.

6. The ULC shall be suitable for fascia or panel mounting.
7. The ULC shall be suitable for operation from a 24 V dc/110 V ac control circuit supply.
8. The ULC shall be suitable for operating pump units installed in a wet well classified as a hazardous area.

#### **3.11.8.3 Functionality**

1. The ULC shall be capable of measuring levels from 0.3 m to 15 m with an accuracy of 0.25% or better (based on the distance between the transducer head and the liquid level).
2. The ULC shall be capable of accurately logging the following parameters for each pump unit:
  - a) total volume pumped;
  - b) pump unit efficiency;
  - c) number of hours run (normal operation and run-on hours); and
  - d) number of starts.
3. All operator-programmed settings/control parameters shall be stored in non-volatile memory to ensure that settings/control parameters are not affected by power interruption.
4. The ULC shall allow restricted access to parameter settings (e.g., by means of password protection) and have the ability to secure all programming from inadvertent alteration.
5. Setting/configuration of parameters shall not require the use of a laptop computer.
6. The ULC shall be capable of the following basic pump functions:
  - a) fixing the pump unit duty/standby status (fixed pump function);
  - b) sequentially rotating the pump unit duty/standby status (each time all pump units are stopped) to ensure equal pump unit usage (alternate pump function); and
  - c) allowing one pump unit to be used in preference to the other (pump service ratio function).
7. The ULC shall be capable of allowing the pump units to "run-on" to a level below the normal stop level for a specified time to discharge sediment from the wet well (cleaning/snore cycle). The pump unit "run-on" interval and duration shall be adjustable to allow optimisation of the cleaning cycle without causing pump unit maloperation or damage.
8. The ULC shall be capable of randomly varying the pump unit start and stop points within a selectable range to minimise the build up of grease and other material in the wet well (wall cling reduction).
9. The ULC shall be capable of transmitting a loss of pump efficiency alarm.
10. The ULC shall be capable of transmitting a signal to a flow totaliser to enable the pumped volume to be recorded remotely from the controller.

#### **3.11.8.4 Abnormal Operation**

##### **Failure of the Pumping Station Power Supply**

1. If the power supply to the pumping station fails or there is a phase failure, the control system shall transmit a "Mains Failure" alarm to telemetry.
2. On the restoration of the power supply after a mains/phase failure, the control system shall automatically resume normal operation including where appropriate pump unit restart.

### **Pump Unit Failure (Initiated by Hard-wired Pump Unit Protection Systems)**

3. The control system shall incorporate the following hard-wired pump unit protection systems:

- a) motor overload protection;
- b) motor over-temperature protection;
- c) pump unit mechanical seal failure protection.

4. If the duty pump unit fails to start, or fails whilst running due to operation of any of the hard-wired protection systems detailed in Clause 3 above, the control system shall:

- a) transmit an alarm to telemetry;
- b) illuminate the relevant fault lamp on the electrical assembly;
- c) start the standby pump unit; and
- d) inhibit the duty pump unit from running.

Note: The pump seal leak sensor is for alarm monitoring only and shall only shut down the pump if it is installed in a hazardous area.

5. On rectification of the fault, the control system shall automatically resume normal operation including where appropriate duty pump unit restart.

6. If the standby pump unit fails to start, or fails whilst running due to operation of any of the hard-wired protection systems detailed in Clause 3 above, the control system shall:

- a) transmit an alarm to telemetry;
- b) illuminate the relevant fault lamp on the electrical assembly; and
- c) inhibit the standby pump unit from running.

7. On rectification of the fault, the control system shall automatically resume normal operation including where appropriate standby pump unit restart.

8. If the hard-wired protection system detailed in Clause 3 (a) above is activated, the control system shall allow the operator a maximum of three remote resets after which the drive shall be locked out.

### **Interruption/loss of Ultrasonic Signal**

9. The ULC shall be configured to transmit a "Loss of Echo" alarm to telemetry if there is an interruption/loss of signal from the ultrasonic transducer in the wet well (the pumping station will be effectively under back-up level control until the fault is rectified).

10. In the event of the above, the ULC shall de-energise all pump unit relays to remove pump unit control from the ULC.

11. To prevent "nuisance" switching between ULC and back-up control, the ULC shall be configured so that transmission of alarms/de-energising of pump unit relays only occurs if there is an interruption/loss of signal for a time period greater than one minute.

### **Back-up Control Mode**

12. The back-up control mode shall be configured as a hard-wired control system operating independently of the pump controller/ULC.

13. Upon receipt of a "High Wet Well Level" signal from the back-up level control, the control system shall start pump unit 1 and continue to run it under the control of a timer. The timer shall be configured so that the pump unit operates while the back-up float switch is activated plus a pre-set time period. The pre-set time period shall equal the time taken for the pump unit to pump from the

high wet well level to L2, assuming that there are no incoming sewage flows into the wet well (the pump unit will, therefore, stop before the level reaches L2 if there are incoming sewage flows).

14. Pump unit 1 shall continue to start on each operation of the high-level float switch until pump controller/ULC control of the pump units is restored.

15. If pump unit 1 fails to start in back-up control mode, pump unit 2 shall start and subsequently run every time the high-level float switch is operated.

16. If pump unit 1 fails when running in back-up control mode, pump unit 2 shall start and run until the pump timer expires. Subsequently, pump unit 2 shall run every time the high-level float switch is operated.

17. Duty changeovers shall be inhibited in back-up control mode.

18. On rectification of the fault that resulted in the high wet well level/back-up control mode, the control system shall automatically revert to pump unit control via the ULC.

### **High-high Wet Well Level**

19. An extra high level alarm shall also be provided by a float switch, mounted to operate just prior to the surface flooding (L5). This shall be connected to the telemetry RTU such that an "Overflow Operating" alarm is still transmitted during power supply interruptions utilising the built-in RTU battery backup supply.

### **3.11.9 Functional Units – Form 4 Assemblies**

#### **3.11.9.1 General**

1. The electrical assembly shall, as a minimum, incorporate the following functional units:

- a) an incomer compartment;
- b) a "Pump Unit No. 1" motor starter compartment;
- c) a "Pump Unit No. 2" motor starter compartment;
- d) a common control compartment; and
- e) a cable marshalling compartment or cable-way.

2. The form of separation of the electrical assembly shall be Form 4. Separation of functional units shall be achieved by partitions or barriers and not via the integral housing of a device.

#### **3.11.9.2 Incomer Compartment**

1. The electrical assembly shall be supplied from one incoming power supply from the DNO with the facility for a mobile generator supply.

2. The incomer compartment shall, as a minimum, accommodate the following equipment and facilities:

- a) two 4-pole (3-phase and switched neutral) fuse switches with suitably-rated HRC fuses, mechanically interlocked and assembled to form a switch for the mains and standby generator supplies. The switch shall be labelled "Mains/Off/Generator";
- b) a phase failure, phase reversal and low voltage protection relay to provide a "Mains Failure" telemetry signal. The phase failure detection relay shall be connected downstream of the "Mains/Off/Generator" switch;
- c) a set of fuses and a neutral link for the phase failure relay and voltmeter (see sub-clause 3 below);
- d) control circuit transformer (CCT) for the common control compartment (CCC); and
- e) power monitoring facilities if the rating of each pump unit is above 10 kW.

3. The following equipment shall, as a minimum, be mounted on the door of the incomer compartment:

- a) the common operating handle for the two 4-pole (3-phase and switched neutral) fuse switches. This shall be door-interlocked and padlockable in the “Off” position;
- b) a voltmeter, scaled 0-500 V, and 7-position selector switch;
- c) an ammeter; and
- d) a fuse-fed, single phase and neutral distribution board, complying with BS EN 61439-3, with integral isolator and hinged cover. All MCBs, RCDs and RCBOs incorporated within the distribution board shall comply with BS EN 60898, BS EN 61008 and BS EN 61009, respectively, and be padlockable in the “Off” position.

### 3.11.9.3 Control Circuit Supplies

1. Control circuit supplies shall comply with the requirements of BS EN 60204-1. The control circuit supply voltage shall be 110 V ac.

2. The common control and motor starter functional units shall each be provided with a dedicated control circuit transformer (CCT).

3. The common control and motor starters shall each be provided with a means of switching, isolation and short-circuit protection for the incoming control circuit supplies. Control circuit supplies shall be energised when the associated fuse switch is in the “On” or “Test” position.

4. The primary and secondary windings of all CCTs shall be protected by fuses or double pole MCBs. Removable neutral links shall be provided if protection is afforded by fuses.

5. CCTs shall be double-wound and comply with the relevant parts of BS EN 61558.

6. CCTs shall have one side of their secondary windings earthed. CCTs shall incorporate a separate earth screen for each secondary voltage, with each screen having a connection point on the transformer terminal block. A common protective conductor shall be used for earthing the screen terminals. Neutrals or negatives of control circuit supplies shall be connected to earth at one point only.

7. CCTs shall be wired as follows:

- a) P1 – 400 V L1;
- b) P2 – 400 V L2;
- c) S1 – 110/24 V neutral; and
- d) S2 – 110/24 V live.

8. The power rating of each CCT shall be equal to the maximum “hold-in” VA rating of all simultaneously-energised control equipment plus the “pull-in” VA rating of the largest device, or the total of all devices that may operate simultaneously, whichever is the greater.

### 3.11.9.4 Motor Starter Compartments

1. Each motor starter compartment shall, as a minimum, accommodate the following equipment:

- a) a triple-pole fuse switch with three suitably-rated HRC fuses and auxiliary switching of all live and neutral control circuits (complete with test position);
- b) motor contactor(s);
- c) 3-phase thermal overload relay with single phasing protection;
- d) a control circuit transformer, control circuit fuses and links;
- e) additional motor protection systems (see Clause 3 below);
- f) all necessary relays, timers (including proprietary brown-out and re-start relays and timers) and intrinsically-safe barriers in the Instrumentation Control and Automation (ICA) section.

2. With respect to Clause 1a above, when the fuse switch is in the “Test” position, only control circuit voltages shall be present within the compartment.
3. With respect to Clause 1e above, motor starters shall incorporate the following additional motor protection systems:
  - a) motor over-temperature; and
  - b) pump unit mechanical seal failure.
4. All motor protection systems shall be of the electrically-latched and manually-reset type.
5. The following equipment shall, as a minimum, be mounted on the door of each motor starter compartment:
  - a) the operating handle for the fuse switch. This shall be door-interlocked and padlockable in the “Off” position ”
  - b) a “Hand/Off/Auto” selector switch;
  - c) a “Common Fault Reset push button;
  - d) a “Pump Unit Start” push button;
  - e) a “Pump Unit Stop” push button;
  - f) a “Pump Unit tripped lamp;
  - g) a “Pump Unit Running” lamp;
  - h) an “Auto-available” lamp;
  - i) individual fault lamps;
  - j) an ammeter; and
  - k) an “Hours Run” meter.
6. All motor starters shall provide Type 2 Co-ordination to BS EN 60947-4.
7. The proprietary brown-out timer shall instigate an automatic reset of the protection circuits upon reinstatement of control circuit supplies or any disturbance of the control circuit supplies likely to result in the mal-operation of the control circuits or relays.
8. If the wet well is classified as a hazardous area, the motor starters shall incorporate all necessary hazardous area facilities (e.g., motor over-temperature protection systems, intrinsically-safe barriers, etc.) in compliance with the requirements of the relevant Standard and Certificate of Conformity.
9. Where submersible pumps are installed in chambers and enclosed with solid covers, an emergency stop facility shall not be required. In other situations, an emergency stop risk assessment shall be carried out by the designer.

#### **3.11.9.5 Common Control Compartment**

1. The common control compartment (CCC) of the control panel shall, as a minimum, accommodate the following common control equipment (CCE):
  - a) a double pole (single-phase and neutral) fuse switch with auxiliary switching of all live and neutral control circuits;
  - b) separate fuses and links for the ULC, control circuits and back-up float switch level control system;
  - c) a ULC (or equivalent) to enable start, stop, control and sequencing of the pump units to control the sewage level in the wet well. The mode of operation of the ULC system shall be as specified by Scottish Water;
  - d) a back-up float switch level control system relay and timer to operate a given pump unit for a set period (using a high-level float switch in the wet well) in the event of failure of the ULC system; and



- e) a separate “high-high” level float switch relay for a high level alarm (operated from a separate float switch in the wet well).

2. With respect to Clauses 1d and 1e, if the wet well is classified as a hazardous area, all connections to float switches shall be via intrinsically-safe connections/barriers.

3. In addition to HMI (HMI) for the ULC (or equivalent), the following equipment shall, as a minimum, be mounted on the door of the CCC:

- a) the operating handle for the fuse switch. This shall be door-interlocked and padlockable in the “Off” position;

4. The design and construction of the CCC shall enable safe inspection, testing, calibration and diagnostic activities to be carried out with the CCE energised and accessible. Safe testing shall be afforded by the use of extra-low voltage systems and segregation of circuits employing different voltages. Additional localised shrouding of circuits above extra-low voltage shall be provided to IP2X as a minimum.

5. 110 V ac supplies to the CCC shall be derived from the control transformer housed in the incomer compartment.

6. Every circuit within the CCC shall be provided with a clearly-identifiable means of switching and isolation for individual items or groups of equipment, as required, for the correct operation of the pumping station. Suitably-rated overcurrent protection devices shall be provided at all points necessary for the protection and isolation of every circuit and to minimise disruption to the overall system on failure of a component part of that system.

7. Apparatus and systems associated with hazardous area installations, as defined in BS EN 60079-10-1, shall be segregated from other CCE in an approved manner in compliance with the requirements of the relevant Standard and Certificate of Conformity.

8. Terminals for connecting an externally-mounted telemetry outstation to the I/O of the electrical assembly shall form part of the CCE and be labelled “Telemetry Terminals”.

#### **3.11.9.6 Cable Marshalling Compartment or Cable-way**

1. A cable marshalling compartment or cable-way shall be provided for marshalling outgoing and bus wiring cables. It shall be configured to provide adequate access to all cables entering or leaving functional units.

2. Incomer, motor starter, CCE and telemetry terminals shall not be located within this compartment.

3. This compartment shall incorporate a common, solid earth bar or stud arrangement, see 3.11.4.2 and 3.11.4.3 of this Specification.

### **3.12 FUNCTIONAL UNITS - FORM 1 ASSEMBLIES**

#### **3.12.1 General**

1. Where a Form 1 electrical assembly is provided, the incomer equipment shall not be incorporated into the assembly but shall be installed separately within the kiosk.

#### **3.12.2 Incomer Equipment**

1. The electrical assembly shall, as a minimum, incorporate the following functional units:

- a) control circuit supplies;
- b) a "Pump Unit No. 1" motor starter;
- c) a "Pump Unit No. 2" motor starter; and

- d) a common control compartment.
2. The form of separation of the electrical assembly shall be Form 1.
  3. The incoming supply cable terminals shall be segregated and shrouded from other terminals and shall be wired directly onto the main incoming switching and isolation device.
  4. Components associated with the same starters or control functionality shall be grouped together in a logical order. The components of different starters shall be segregated by additional space.

### 3.12.3 Incomer

1. The electrical assembly shall be supplied from one mains incoming power supply from the DNO.
2. The incomer shall, as a minimum, incorporate the following equipment and facilities:
  - a) a 4-pole (3-phase and switched neutral) fuse switch with three suitably-rated HRC fuses. The switch shall be labelled "On/Off/Test";
  - b) a phase failure, phase reversal and low voltage protection relay to provide a "Mains Failure" telemetry signal. The phase failure detection relay shall be connected downstream of the "On/Off/Test" switch; and
  - c) a set of fuses and a neutral link for the phase failure relay and voltmeter (see Clause 3 below).
3. The following equipment shall, as a minimum, be mounted on the door of the electrical assembly adjacent to the incomer:
  - a) the common operating handle for the triple pole and switched neutral fuse switch. This shall be door-interlocked and padlockable in the "Off" position;
  - b) a voltmeter, scaled 0-500 V, and seven-position selector switch;
  - c) an ammeter;
  - d) a fuse-fed single-phase and neutral distribution board, complying with BS EN 61439-3, with integral isolator and hinged cover. All MCBs, RCDs and RCBOs incorporated within the distribution board shall comply with the requirements of BS EN 60898, BS EN 61008, BS EN 61009, respectively, and be padlockable in the "Off" position.

### 3.12.4 Control Circuit Supplies

1. Control circuit supplies shall be housed within the electrical assembly adjacent to the incomer.
2. Control circuit supplies shall comply with the requirements of BS EN 60204-1. The control circuit supply voltage shall be 110 V ac.
3. The primary and secondary windings of the CCTs shall be protected by fuses or double pole MCBs. Removable neutral links shall be provided if protection is afforded by fuses.
4. CCTs shall be double-wound and comply with the relevant parts of BS EN 61558.
5. CCTs shall have one side of their secondary windings earthed. CCTs shall incorporate a separate earth screen for each secondary voltage, with each screen having a connection point on the transformer terminal block. A common protective conductor shall be used for earthing the screen terminals. Neutrals or negatives of control circuit supplies shall be connected to earth at one point only.
6. CCTs shall be wired as follows:
  - a) P1 – 400 V L1;
  - b) P2 – 400 V L2;

- c) S1 – 110/24 V neutral; and
- d) S2 – 110/24 V live.

7. The power rating of each CCT shall be equal to the maximum "hold-in" VA rating of all simultaneously-energised control equipment plus the "pull-in" VA rating of the largest device, or the total of all devices that may operate simultaneously, whichever is the greater.

### 3.12.5 Motor Starters

1. The electrical assembly shall be provided with two motor starters. Each motor starter shall, as a minimum, incorporate the following equipment:

- a) suitable isolating, overload and short circuit protection device(s);
- b) motor contactor(s);
- c) a 3-phase thermal overload relay with single phasing protection;
- d) control circuit fuses and links;
- e) additional motor protection systems (see Clause 2 below); and
- f) all necessary relays and timers.

2. With respect to Clause 1 e) above, motor starters shall incorporate the following additional motor protection systems:

- a) motor over-temperature protection (if required for hazardous area certification of the motor and/or if recommended by the pump unit manufacturer;
- b) pump unit mechanical seal failure protection.

3. All motor protection systems shall be of the electrically-latched and manually-reset type.

4. The following equipment shall, as a minimum, be mounted on the door of the electrical assembly adjacent to each motor starter:

- a) a "Hand/Off/Auto" selector switch;
- b) a "Common Fault Reset" push-button switch (this may be common to both motor starters);
- c) a "Pump Unit Start" push-button switch;
- d) a "Pump Unit Stop" push-button switch;
- e) a "Pump Unit Tripped" lamp;
- f) a "Pump Unit Running" lamp;
- g) an "Auto-available" lamp;
- h) individual fault lamps; and
- i) an "Hours Run" meter.

5. All motor starters shall provide Type 2 Co-ordination to BS EN 60947-4.

6. The proprietary brown-out timer shall instigate an automatic reset of the protection circuits upon reinstatement of control circuit supplies, or on any disturbance of the control circuit supplies likely to result in the mal-operation of the control circuits or relays.

7. If the wet well is classified as a hazardous area, the motor starters shall incorporate all necessary hazardous area facilities (e.g., motor over-temperature protection systems, intrinsically-safe barriers, etc.) in compliance with the requirements of the relevant Standard and Certificate of Conformity.

8. Where submersible pumps are installed in chambers and enclosed with solid covers, an Emergency Stop facility shall not be required. In other situations, an emergency stop risk assessment shall be carried out by the designer.

### 3.12.6 Common Control Section

1. The common control section (CCS) shall, as a minimum, accommodate the following common control equipment (CCE):

- a) suitable isolating, overload and short circuit protection devices;
- b) separate fuses and links for the ULC system, control circuits and back-up float switch level control system;
- c) a ULC (or equivalent) to enable start, stop, control and sequencing of the pump units to control the sewage level in the wet well. The mode of operation of the ultrasonic level control system shall be as specified by Scottish Water;
- d) a back-up float switch level control system relay and timer to operate a given pump unit for a set period (using a high-level float switch in the wet well) in the event of failure of the ULC system;
- e) a separate high-high level float switch relay for a high-high level alarm (operated from a separate float switch in the wet well); and
- f) all necessary relays and timers (including proprietary brown-out and re-start relays and timers).

2. With respect to Clauses 1 d) and e) above, if the wet well is classified as a hazardous area, all connections to float switches shall be via intrinsically-safe connections.

3. The design and construction of the CCS shall enable safe inspection, testing, calibration and diagnostic activities to be carried out with the CCE energised and accessible. Safe testing shall be afforded by the use of extra-low voltage systems and segregation of circuits employing different voltages. Additional localised shrouding of circuits above extra-low voltage shall be provided to IP4X minimum.

4. Every circuit within the CCS shall be provided with a clearly-identifiable means of switching and isolation for individual items or groups of equipment, as required, for the correct operation of the pumping station. Suitably-rated overcurrent protection devices shall be provided at all points necessary for the protection and isolation of every circuit and to minimise disruption to the overall system on failure of a component part of that system.

5. Apparatus and systems associated with hazardous area installations, as defined in BS EN 60079-10-1, shall be segregated from other CCE in an approved manner in compliance with the requirements of the relevant Standard and Certificate of Conformity.

6. Terminals for connecting an externally-mounted telemetry outstation to the I/O of the electrical assembly shall form part of the CCE and be labelled "Telemetry Terminals".

## 3.13 THE ELECTRICAL INSTALLATION

### 3.13.1 General

1. All components and equipment shall be suitable for their intended duty, particularly with respect to the following:

- a) the electrical supply and load requirements;
- b) the degree of ingress protection (IP rating);
- c) the environmental conditions (particularly corrosion resistance); and
- d) the mechanical properties (especially impact strength).

### 3.13.2 Installation of Components and Equipment

1. All equipment shall be securely mounted using proprietary fixtures and fittings.

2. Equipment terminals and covers shall be readily and safely accessible after installation.

3. The method of equipment installation shall not affect the IP rating of the equipment.
4. Unless otherwise agreed with Scottish Water, cable access to all electrical enclosures shall be bottom entry.

### 3.13.3 Cables

1. All cables shall be manufactured, tested and certified in accordance with a procedure approved by the British Approvals Service for Electric Cables (BASEC) and shall comply with the latest relevant British or harmonised European Standards.
2. Cable selection and sizing shall comply with the requirements of BS 7671 and the recommendations of 'IET Guidance Note 1: Selection and Erection of Equipment', with particular reference to Appendix H of that document.
3. All cables shall have copper conductors to BS EN 13602. Cores of cross-sectional area greater than 1.5 mm<sup>2</sup> shall be stranded or flexible.
4. If neutral conductors are provided, they shall be of the same cross-sectional area as the associated line conductor.
5. Any spare cores shall be terminated at both ends and one end earthed.
6. The types/ratings and sizes of cables selected for a given application shall comply with Table 10.

**Table 10 Types/Ratings and Sizes of Cables**

<b>Application</b>	<b>Type/Rating</b>	<b>Minimum Conductor CSA</b>
Electricity distributor's 3-phase and neutral cable tails	BS 6346 rated at 600/1000 V	According to duty
Installation earth cable	BS 6231 rated at 600/1000 V	16 mm <sup>2</sup>
Kiosk lighting, heating and power cables <sup>1</sup>	BS 6004 (Table 1) rated at 450/750 V	1.0 mm <sup>2</sup> (lighting) 2.5 mm <sup>2</sup> (heating and power)
Pump unit cables	Refer to Section 3.8	2.5 mm <sup>2</sup>
Ultrasonic level sensor cable	As supplied by manufacturer	As supplied by manufacturer
Float switch cables	As supplied by manufacturer	As supplied by manufacturer
Electrical assembly to telemetry monitoring station	PAS 5308-2/BS EN 50288-7	0.5 mm <sup>2</sup>
Note 1: The colour of the insulation on all cables shall comply with the Scottish Water colour code for wiring and relevant European Standards.		

### 3.13.4 Installation of Cables

1. Cable installation shall comply with the requirements of BS 7671 and the recommendations of 'IET Guidance Note 1: Selection and Erection of Equipment' (2011) with particular reference to Appendix I of that document.
2. Cables and cable support systems shall not be fixed to pump unit guide rails.
3. Joints shall not be permitted in individual power and control cables, except at junction boxes.

4. Cables that may be subject to accidental mechanical damage shall be suitably protected. The degree of mechanical protection offered to cables (e.g., installation in PVC ducting, metal conduit, etc.) shall be appropriate to the likelihood and consequences (i.e., risk) of cable damage.

5. Ducts shall be provided for installation of the following:

- a) the DNO's incoming power cable. One duct shall be provided, sized in accordance with the DNO's specification (e.g., colour, size, etc.) and routed between the point of supply and the kiosk plinth in accordance with the DNO's requirements;
- b) the installation earth cable. One duct shall be provided, 50 mm in diameter, and routed between the point of supply and the kiosk plinth;
- c) the pump unit cables. Two ducts shall be provided, 150 mm in diameter, and routed between the wet well, valve chamber and the kiosk plinth, see 3.13.7;
- d) the ultrasonic level sensor and float switch cables. One duct shall be provided, 100 mm in diameter, and routed between the wet well, valve chamber and the kiosk plinth;
- e) the flow meter. One duct shall be provided, 100 mm in diameter and routed between the flow meter sensor and the kiosk plinth;
- f) minimum segregation/separation between Band 1 (ELV signal) and Band 2 (LV power) cables as defined in BS 7671, shall be 300 mm;
- g) where the signal is to be transmitted through the public telephone network, one duct shall be provided for the telemetry cable, sized according to the telecommunications supplier's requirements, and routed between the kiosk plinth and the point of connection to the public telephone network; and
- h) where the telemetry signal is to be transmitted by other means, Scottish Water shall be consulted regarding their requirements.

6. Ducts shall consist of rigid black or grey PVC-U pipe, complying with BS EN 1401-1 and BS 4660.

7. Changes in direction of ducts shall be achieved using long radius bends. Ducts shall have self-aligning, watertight joints and a smooth internal bore. All accessories shall be proprietary and made from the same material as the duct.

8. The ducts for the pump unit cables shall enter the wet well near to its top and terminate behind the pump guide rails so that the pump unit cables can be easily reached from the top of the wet well.

9. Ducts shall terminate approximately 75 mm proud of the surface of the plinth.

10. Depth of cover in soft ground shall be a minimum of 500 mm above the crown of the duct.

11. On completion, all ducts shall have a swab drawn through to clear them of obstructions.

12. Ducts shall be left with an excess 1 m length of 8 mm diameter nylon drawcord in place, anchored at each end.

13. After installation of cables, all ducts shall be sealed with an approved proprietary sealant. Where the seal is providing a barrier between hazardous and non-hazardous areas, a transit plate arrangement or other approved proprietary sealing arrangement shall be installed, tested and certified as DSEAR compliant.

14. Conduit shall be provided for installation of the cables associated with the kiosk lighting systems, heating systems and/or socket outlets.

15. Conduit shall be manufactured from 20 mm diameter, high-impact resistance, heavy-gauge PVC-U and comply with BS EN 50086-1 and BS EN 50086-2. The outside diameters of conduits and the dimensions of threads for conduits and fittings shall comply with BS EN 60423. All fittings shall be glued.

### **3.13.5 Glanding, Identification and Termination of Cables**

#### **3.13.5.1 Glanding**

1. The construction and performance of cable glands shall comply with BS EN 62444.
2. Cable glands shall be suitable for the type of cable being installed and its intended operating environment. Cable gland selection shall, as a minimum, consider the following performance requirements:
  - a) mechanical properties;
  - b) electrical properties; and
  - c) resistance to external influences. The minimum degree of ingress protection shall be IP66 in accordance with BS EN 60529.
3. All glands selected for use on SWA cables shall incorporate sealing on the outer sheath.
4. Where a cable is glanded through a painted or otherwise coated metallic surface, provision shall be made to ensure earth continuity between the gland and the enclosure.

#### **3.13.5.2 Identification**

1. Cable cores shall be identified at both ends by interlocking ferrules or another approved system. Cables shall be uniquely identified.
2. Where provided, identification labels shall be legible, durable and securely affixed to the cable sheath by means of buckle-type straps, and shall carry the cable reference in PVC channel strip. The reference character sizes shall be not less than 3 mm high.

#### **3.13.5.3 Termination**

1. Termination of cables shall comply with Section 3.13.5.3.
2. All of the strands forming the conductor shall be connected at the point of termination.
3. Wiring shall be terminated using crimped connectors or lugs, both of which shall be suitable for the conductor and the type of termination, as recommended by the manufacturer.
4. For screened signal cables, screens shall be connected to earth using a proprietary 360° connection. The termination of screened signal cables shall comply with the Electrical Equipment (Safety) Regulations 1994 and the Electromagnetic Compatibility Regulations 2006.
5. For screened signal cables, at the isolated end of the cable, a suitable length of the overall sheath and the screen shall be removed and a 30 mm long silicone rubber oversleeve installed over the point of separation of conductors, screen and overall sheath.

#### **3.13.6 Junction Boxes**

1. Junction boxes shall be designed for bottom cable entry.
2. Junction boxes shall be sized so that there is adequate space between the point of cable entry and the terminals, such that cable cores may be spread, loomed, identified, terminated and subsequently removed for testing, without experiencing excessive bending or stress.
3. Junction boxes shall be provided with an adequate means of earthing.
4. Terminals shall be clipped to rails fixed to the back of the junction box or supported off brackets integral with the junction box.

5. When a junction box is open, the degree of ingress protection to any live part, or to any part that could be energised at above low voltage during any test procedure, shall be a minimum of IP2X.

6. Junction box lids or covers shall be secured closed by captive, threaded fasteners.

### **3.13.7 Connection of Pump Unit Cables**

1. Connection of pump unit cables is detailed in 3.11.5.4.

### **3.13.8 Earthing and Bonding**

#### **3.13.8.1 General**

1. All earthing and equipotential bonding shall be performed in accordance with:

- a) BS 7671, with particular reference to the recommendations of 'IET Guidance Note 5: Protection Against Electric Shock' and 'IET Guidance Note 8: Earthing and Bonding';
- b) BS 7430;
- c) the Electricity Safety, Quality and Continuity Regulations 2002.

2. Typical earthing arrangements are shown in Figure 33.

3. Prior to design of the earthing system, the type of earthing and the external earth fault loop impedance shall be obtained from the DNO. The documentary evidence of this information shall be provided on request. The contractor shall liaise with the DNO to ensure the earthing arrangements meet with their requirements.

4. The earthing system shall be compatible with any existing earthing system.

5. A removable link shall be provided to disconnect the pumping station from the DNO's main earth terminal (MET), in the event that a mobile generator is connected to the pumping station.

Note: This is a separate requirement to that in 3.13.8.2.2.

#### **3.13.8.2 Earth Electrode**

##### **General**

1. The contractor shall design and install the earthing system. The system shall include the earthing and bonding of all exposed metalwork, including any supplied under other contracts, and shown on the tender drawings.

2. The contractor shall provide a main earth bar and earth rod or mat system. Each earth rod (mat) shall have an inspection pit and cover. The earth rods (mats) shall not be driven in to any civil works "made up ground" or "fill".

3. The contractor shall carry out soil resistivity tests and shall provide an earth rod system in accordance with BS 7430. The earth rod resistance shall be tested when disconnected from the rest of the earthing system.

4. The earth electrode shall be connected to the DNO's main earth terminal (MET) via a removable test link.

5. A stud terminal shall also be provided in the kiosk for connection of the mobile generator star point to the earth electrode. A label shall be fixed adjacent to the stud terminal stating "Bolted Earth Connection Shall Be Made Before Generator Is Connected With Main Plug And Socket".



## **Earth Electrode**

6. The earth electrode shall comprise a number of interconnected earth rod assemblies, driven into the ground external to the kiosk.
7. Each earth rod assembly shall comprise a number of copper-clad, high-tensile steel rods. Rods shall be at least 16.0 mm (nominal) in diameter with hardened steel tips and driving caps. Individual rods shall be no more than 1.2 m long. The copper cladding shall be molecularly bonded to the steel and be not less than 0.25 mm thick.
8. Connections between individual rods shall be by screwed joints. A corrosion-inhibiting paste shall be applied to all threads before assembly.
9. A single earth rod assembly shall be not more than 6 m long and the separation between adjacent earth rod assemblies shall be not less than 1.25 times the length of the longest earth rod assembly.
10. The earth rod assemblies shall be interconnected using earthing conductors, consisting of bare copper tape, sized according to the anticipated fault current. The final earthing conductor (which will connect the earth electrode to the main earth terminal (MET)) shall be a copper tape or stranded conductor and shall be sheathed in green/yellow PVC insulation.
11. Inspection pits shall be installed at the point of connection of every earthing conductor to an earth rod assembly. Inspection pits shall be mounted flush with the finished ground level and be fitted with a prominently-labelled, removable lid. If the pit is installed in an area of hardstanding, the pit and lid shall be manufactured from concrete. In each inspection pit, a label, stating "Safety Electrical Earth Do Not Remove", shall be permanently attached to the point of connection between the earth rod assembly and earthing conductor.
12. The earth electrode shall provide a maximum effective earth resistance of 10 Ohms.

### **3.13.8.3 Bonding**

#### **General**

1. PVC-coated copper tape or cable shall be used for bonding connections (i.e., aluminium or copper-clad aluminium conductors shall not be used).
2. Metal tabs worded "Safety Electrical Earth – Do Not Remove" shall be attached to all bonding connections.

#### **Main Equipotential Bonding**

3. All extraneous conductive parts of the pumping station shall be connected to the main earthing terminal (MET).
4. The bonding conductor shall be connected to the various connection points in the kiosk, valve chamber and wet well, as indicated in Figure 33. The bonding conductor shall be continuous and not cut at each connection.

#### **Supplementary Equipotential Bonding**

5. Any extraneous conductive parts, i.e., any metalwork not forming part of the pumping station (electrical) but which itself may have some connection with the mass of earth and which is in such a position that a person could make simultaneous contact between it and an exposed conductive part of the electrical installation, shall be bonded to the nearest exposed conductive part, unless it can be shown to be in otherwise good contact with the earthing system.

6. Supplementary bonding of a permanent and reliable nature shall be carried out to extraneous conductive parts in a manner that takes due consideration of subsequent maintenance activities.

7. If the use of pipework or equipment with specialised, fully-protective, non-conducting surface preparations cannot guarantee earth continuity (notably across flanged joints) then supplementary earth bonding conductors, or purpose-designed hardware ensuring continuity, shall be used.

8. Metallic cable and wiring support systems shall be bonded to all non-electrical services.

#### **3.13.8.4 Joints and Connections**

##### **Joints**

1. Joints in cables and tapes shall not be permitted.

##### **Connections**

2. Connections shall be made:

- a) to main earthing terminals by phosphor bronze set screws and nuts; and
- b) to earth rods by bronze, gunmetal, or copper clamps, with phosphor bronze bolts.

3. Termination of cables shall be by lugs jointed to the cable by an exothermic welding process, by crimping or by compression joints complying with BS EN 61238.

4. If holes are drilled in copper tape for connection to items of plant, the effective cross-sectional area of the connection shall be maintained.

5. Surfaces of all equipment to which protective conductors are connected shall be clean, and free from paint and other non-conducting material. Surface preparation shall be removed at the point of contact, with the exception of galvanised or similar metallic preparations. Any surface preparations that have been removed shall be made good upon completion of the connection to preserve the life and purpose of both the surface and the protective conductor.

##### **Protection**

6. All connections that are exposed to the elements, or not contained inside switchgear enclosures or other electrical apparatus, shall be protected immediately after making with a suitable surface preparation. This preparation shall be easily removable without cleaning compounds and shall not be harmful to personnel, or to the materials to which it is applied. It shall not impair electrical conductivity.

#### **3.13.9 Instrumentation**

Instrumentation shall be selected from the Scottish Water Instrumentation Catalogue or approved equivalent.

##### **3.13.9.1 Flow meter**

###### **General**

1. All new foul-only pumping stations shall have a flow meter installed to measure pass forward flow (PFF) to facilitate pumping efficiency analysis, intelligent telemetry alarming and business reporting. The preferred flow meter shall be an electromagnetic flow meter in the pumping main giving a 4-20 mA output and a pulse per m<sup>3</sup> output with an accuracy of  $\pm 2\%$ . For difficult installations where it is impractical to install an electromagnetic flow meter, the alternative shall be an insertion ultrasonic flow meter using a cross-correlation algorithm giving 4-20 mA output proportional to derived flow and an accuracy of  $\pm 5\%$ .

2. The pumped flow shall be displayed locally in the control kiosk as an instantaneous value. Flow logging and instrument failed alarm signals shall be provided.

### **Flow Meter Installation**

3. Where flow is measured for regulatory purposes, the monitoring and installation method shall be agreed with Scottish Water.

4. Installation of flow meters shall be in line with the following requirements:

- a) the flow meter shall be installed within the valve chamber in accordance with the manufacturer's specifications. For pumping stations with a pumping main greater than 100 mm diameter where it is not possible to construct a flow meter chamber downstream of the valve chamber an electromagnetic flow meter shall be provided within the valve chamber but shall be installed so as to provide as much downstream and upstream straight pipework as possible;
- b) for pumping stations with a pumping main less than or equal to 100 mm diameter, the flow meter may be mounted in the valve chamber where space permits;
- c) all in-line flow meters shall be installed with at least one pipework flange adaptor to facilitate removal and replacement. Where it is impractical to drain the pumping main into the wet well, an isolating valve shall be installed downstream of the flow meter to facilitate removal;
- d) the flow meter shall be installed within the open area directly below the chamber hatch and not underneath the roof slab;
- e) pipeline flow meter electrodes/sensors shall be located on the horizontal plane to prevent problems with air bubbles at the top of the pipe and sediment at the bottom, both of which will affect meter performance;
- f) the signal converter shall include background illumination with an alphanumeric display to indicate flow rate, totalised values, settings and faults. All programming shall be achievable via the front keypad. The signal converter shall be available in compact, wall and panel mounting formats and be rated to IP55 minimum;
- g) two fully configurable relay outputs shall be provided as a minimum;
- h) the flow meter earthing system shall be correctly installed since electrical continuity is required between the flowing fluid and the metal body of the flow meter. Integral earthing electrodes shall be used;
- i) flow meter test and calibration certificates shall be provided in the O&M manuals.

### **3.13.9.2 Ultrasonic Level Instrument Selection**

#### **Installation of Ultrasonic Level Instrument**

1. Where practicable, the ultrasonic level sensor head shall be suspended from a stainless steel mounting plate affixed over an aperture in the wet well cover slab, so that it can be easily removed for adjustment or replacement (e.g., hinged), without the need for man-entry into the wet well. The mounting plate and its securing bolts shall be recessed into the cover slab to provide a trip-free level surface. Alternatively, where the design of the wet well requires the sensor head to be positioned in the opening in the cover slab, it shall be affixed to a stainless steel hinged bracket in such a manner that it can be removed/adjusted with the safety grids/grilles in place. The sensor head shall be positioned so as not to restrict manual access into the wet well chamber.

2. The ultrasonic level detector head shall be mounted to ensure that the minimum blanking distance is not compromised under any conditions.

3. All float switches shall be supported by stainless steel brackets.

4. Mounting plates, hinged brackets and brackets shall be made from stainless steel number 1.4404 to BS EN 10088-1.

# SECTION 3D – VALVE SPECIFICATION

## 3.14 INTRODUCTION

1. This Specification defines the requirements for valves for use in pumping stations for Scottish Water.

## 3.15 GATE (SLUICE) VALVES

1. Gate valves shall comply with BS EN 1171 and incorporate non-rising valve spindles. The inlet and outlet connections of the valves shall terminate with flange-type PN16 (minimum), as detailed in BS EN 1092. The valves shall be of the resilient seat type.

2. Gate valves shall be fitted with removable cast iron handwheels, which shall have the direction of opening/closing of the valve clearly and indelibly marked on their surface.

3. Horizontally-mounted valves shall be provided with extension spindles, headstocks and support brackets, if the valve chamber is greater than 1200 mm in depth. Spindles shall extend to approximately 50 mm below the underside of the access cover, so that valves can be opened/closed from above ground using "T" keys, which shall be supplied by the developer.

4. Gate valves shall be designed to close when handwheels/"T" keys are rotated in a clockwise direction.

5. Where macerator pump units are installed with typically 50 mm internal diameter pipework or less, it shall be permissible for threaded connections to be used for valves and pipework. Suitable connectors shall be used to allow dismantling of the pipework to remove valves after the chamber walls have been sealed.

6. Where macerator pump units are installed and threaded couplers are used, any exposed thread shall be painted with a zinc-based paint on completion of the installation.

## 3.16 CHECK (REFLUX) VALVES

1. Check valves shall comply with BS EN 12334 and be of the swing type fitted with external lever arms and counterweights. The inlet and outlet connections of the valves shall terminate with flange type PN16 (minimum), as detailed in BS EN 1092. All lever arm/counterweight assemblies shall be guarded.

2. Check valves shall be designed and sized to close rapidly without shock, and have good seating properties.

3. Check valves shall be non-clogging. The valve design shall ensure that, when the valve disc is in the fully-open position, the size and direction of the flow path is equivalent to that of the surrounding pipework. The valve internals (seats, discs, hinges, etc.) shall be arranged so that there are no projections that could interfere with the passage of solids, rags and fibrous materials. 4. Check valves shall be provided with removable covers, sized to allow adequate access to the valve internals (seats, discs, hinges, etc.). Covers shall be tapped (½ inch BSP) and plugged.

5. Where macerator pump units are installed, the requirement for external levers on check valves does not apply to valves of 50 mm internal diameter or less.

## 3.17 MAINTENANCE/OPERATIONAL ISSUES

1. All equipment within the valve chamber shall be arranged/positioned to allow adequate access for maintenance. Particular attention shall be paid to the following:

- a) the clearance around check valves, to enable removal of the disc hinge pins;
- b) the clearance between the invert of the valve chamber pipework and the valve chamber finished floor level (see Clause 2.26.5);
- c) the clearance between flanged connections and surrounding equipment/structures (see Clause 2.26.5); and
- d) access to screwed couplers for dismantling pipework and removal of valves of 50 mm internal diameter or less used on macerator-type pumping installations.

2. Flange adapters shall be provided to facilitate valve removal and replacement. These shall be tied to the flanges of adjacent pipework to prevent movement of the joint during operation.

# **PART 4 - CIVIL ENGINEERING SPECIFICATION**

Part 4 is an extract from UKWIR Civil Engineering Specification for the Water Industry (CESWI 7<sup>th</sup> edition at the time of publication).

The numbering of the clauses has been altered to suit this document, however the original numbering can be found in CESWI 7 available from UKWIR

Any clauses in this Specification which relate to work or materials not required by the Works shall be deemed not to apply.

The Clause headings and marginal 'Notes for Guidance' are not part of the Specification, and are not to affect the interpretation of either the Specification or the other documents comprising the Agreement.

## **4.1 GENERAL**

*(i) Local differences can arise between GPS and OS co-ordinates.*

#### **4.1.1 DRAWINGS**

1. One copy of the Drawings shall be kept on the Site and shall be available for use by Scottish Water.
2. All levels on the Drawings shall be related to Ordnance Survey Newlyn Datum. Details shall be provided of the level and location of the temporary benchmarks and reference points which are proposed to be used.

#### **4.1.2 SETTING OUT**

1. The developer shall be responsible for setting out the Works and for the correctness of the position and dimensions of all parts of the Works.

#### **4.1.3 QUALITY OF MATERIALS, WORKMANSHIP AND TESTS**

1. All materials and workmanship shall be subjected, from time to time, to such tests as Scottish Water may direct.
2. If required by Scottish Water, a list of the proposed suppliers and sources of materials required for the execution of the works shall be submitted. Samples shall be taken in accordance with the appropriate British Standard, where applicable.

#### **4.1.4 EXAMINATION OF WORK**

1. Scottish Water shall be afforded the opportunity to examine any work which is about to be covered up or put out of view, and to examine foundations before permanent work is to be placed thereon.
2. At least one clear working day's notice shall be given to Scottish Water before any formation is covered with permanent work and before testing any pipeline.

#### **4.1.5 EXISTING PUBLIC SEWERS**

1. All necessary precautions shall be taken to avoid causing any damage to, or interference with flow in, existing public sewers and shall ensure that debris, silt and mud, etc., do not enter the sewer. All necessary precautions shall be taken to avoid misconnection to existing public sewers.
2. No existing sewers or drains shall be connected to the Works or vice versa without the sanction of Scottish Water.

#### **4.1.6 SAFETY IN SEWERS**

1. Work carried out within or adjacent to any drain, sewer or at

a wastewater treatment plant (WTP), shall be in accordance with the relevant provisions of Scottish Water's safety procedures.

2. Approval in writing is required from Scottish Water prior to working on any sewer, drain or the operation of any valves, etc., at any wastewater treatment plant (WTP).

#### **4.1.7 BRITISH AND EUROPEAN STANDARDS AND OTHER DOCUMENTS**

1. Any reference to a Standard published by the British Standards Institution, or to the specification of another body, shall be construed equally as reference to an equivalent one.

2. Submissions shall be made in accordance with the latest published Standard which is current on the date the submission is made.

### **4.2 MATERIALS**

#### **4.2.1 STORAGE OF MATERIALS**

1. Materials and components shall be stored in such a manner as to preserve their quality and condition to the standards required by the Specification.

#### **4.2.2 HANDLING AND USE OF MATERIALS**

*(i) An understanding of manufacturer's recommendations is necessary before their applicability can be assessed.*

1. Materials and components shall be handled in such a manner as to avoid any damage or contamination, and in accordance with all applicable recommendations of the manufacturers.

2. Unless otherwise described in the Specification, the use, installation, application or fixing of materials and components shall be in accordance with all applicable recommendations of the manufacturers. Where appropriate, any technical advisory services offered by manufacturers shall be used.

#### **4.2.3 WATER**

1. Water for use with cement shall be of wholesome quality.

2. If water for the Works is not available from the public supply, approval shall be obtained regarding the source of supply and manner of its use. Water from the sea or tidal rivers shall not be used for structural concrete.

#### **4.2.4 AGGREGATES FOR CONCRETE**

*(i) For the limitation of total chloride ion content of the*

1. Aggregates for concrete shall comply with the relevant provisions of BS EN 12620, PD 6682-1 and BS 8500-2.2. The



concrete mix see Section 4.4.2. British Standards no longer contain specific chloride limits for aggregates.

(ii) Marine aggregates may be used providing Scottish Water is satisfied that the total chloride content of the concrete mix complies with the Specification.

(i) The requirement for sands to be washed is additional to the requirements of the Standards, but is in line with the main conclusion of CIRIA Report R59 'Building Sands: Availability, Usage and Compliance with Specification Requirements'.

(i) The lower strength limit of 20 N per mm<sup>2</sup> for the use of sulphate-resisting Portland cement is

water absorption of aggregates for concrete designed to retain an aqueous liquid shall not exceed 3% when measured in accordance with BS EN 1097-6.

3. The proportion of coarse recycled aggregate and coarse, recycled concrete aggregate shall not exceed 20% by mass of the total coarse aggregate in concrete. Fine, recycled aggregate or fine, recycled concrete aggregate shall not be used in concrete.

4. Recycled aggregates and recycled concrete aggregates shall only be used in contact with raw or potable water where it has been demonstrated that they are suitable for this application

#### **4.2.5 AGGREGATES FOR HIGH STRENGTH CONCRETE WEARING SCREEDS**

1. Aggregates for high strength concrete wearing screeds (granolithic finish) shall comply with BS EN 12620 and PD 6682-1 and be 10 mm nominal size, graded in accordance with Table E.1 in PD 6682-1 and shall have a Los Angeles Coefficient of no greater than 30.

#### **4.2.6 SANDS FOR MORTAR AND GROUT**

1. Sands for mortar and grout shall comply with BS EN 13139 and PD 6682-3.

2. Sands for external rendering shall comply with relevant provisions of BS EN 13139 and PD 6682-3.

3. All sands required to comply with BS EN 12620 and PD 6682-1, BS EN 13139 and PD 6682-3 shall be washed sands.

#### **4.2.7 PULVERISED-FUEL ASH**

1. Pulverised-fuel ash (pfa) for use as a component material in cementitious grout or non-structural concrete shall comply with BS 3892-2 and -3.

#### **4.2.8 CEMENT**

1. Cement shall either:

a) be factory-produced by the cement manufacturer and comply with the provisions of the appropriate Standard, as set out below; or

consistent with BS 4027 for standard mixes.

(ii) 'BRE Special Digest 1: Concrete in Aggressive Ground' deals with sulphate-resistance classification.

(iii) For a comprehensive specification for cement see CESWI 7<sup>th</sup> edition.

Cement Type	Standard
Portland cement (CEM I)	BS EN 197-1
Sulphate-resisting Portland	BS 4027

b) be combinations, complying with BS 8500-1 Annex A, of CEM 1 cement conforming to BS EN 197-1 and fly ash conforming to BS EN 450-1 or blast furnace slag conforming to BS EN 15167-1.

2. For precast concrete pipes or inspection chambers complying with BS EN 1916, BS EN 1917 and BS 5911, a minimum class 3, sulphate-resistant cement shall be used unless Scottish Water can be satisfied that a lower class will resist attack from soils and groundwater.

#### 4.2.9 READY-MIXED CONCRETE

(i) When ready-mixed, ordinary prescribed mixes to BS 8500 are delivered, the supplier is required to provide, on the delivery ticket, detailed information relating to the concrete being supplied.

1. Where concrete is to be obtained from a ready-mix supplier, the source shall be agreed with Scottish Water and it shall be confirmed to Scottish Water that the supplying plant is approved by a Third Party Certification Body accredited by the United Kingdom Accreditation Service (UKAS) for product conformity.

2. The delivery ticket accompanying each load of ready-mixed concrete shall, in addition to the information prescribed under BS EN 206 Clause 7.3, detail:

a) the type of aggregate;

b) the actual cementitious content and the percentage of any pfa of ggbs included; and

c) the position of the concrete in the Works (details to be inserted at the point of discharge).

3. All delivery tickets shall be kept at the Site and shall be available for inspection by Scottish Water.

#### 4.2.10 LIME FOR MORTAR

1. Lime for mortar shall be in the form of lime putty, complying with the relevant provisions of BS EN 459-1.

#### 4.2.11 CEMENT GROUTS

1. Cement grout for filling drains which are to be abandoned shall be mixed in the relevant proportions indicated in the following Table, using the minimum quantity of water to ensure the necessary fluidity and to render it capable of penetrating the work.

Class	Nominal Mix by Mass		
	Cement	Sand	Pfa
G3	1	10	-
G4	1	-	10

2. Cement grout shall be used within one hour of mixing except where containing a grout retardant admixture.

3. Cement grout for fixing inserts and below plant bases shall include an approved expanding additive.

#### 4.2.12 MORTAR

(i) The alternative mixes are broadly equivalent (see PD 6678) but the use of lime putty or plasticiser gives additional plasticity (see BS EN 998-1 and BS EN 998-2).

(ii) The cement:lime:sand mortar is consistent with Category 1.12 of BS EN 998-1 and BS EN 998-2 and, together with the cement:sand:mortar, is consistent with Designation (i) read-to-use mortar in BS EN 998-2.

1. Mortar shall be mixed only as and when required, in the relevant proportions indicated in the following Table, until its colour and consistency are uniform. The constituent materials shall be accurately gauged, allowance being made for bulking of sand.

Alternative Nominal Mixes by Volume		
Cement:lime:sand	Cement:sand	Cement:sand with plasticiser
1 : ¼ : 3	1 : 3	1 : 2½ to 3

2. Ready-mixed and ready-to-use rendering and masonry mortar shall conform to BS EN 998-1 and BS EN 998-2, respectively.

3. All mortar shall be conveyed fresh to the Works as required for use. Mortar which has begun to set or which has been site-mixed for a period of more than one hour shall not be used. Plasticising and set-retarding mortar admixtures shall comply with BS EN 934-3 and shall be supplied with instructions for use.

#### 4.2.13 STEEL REINFORCEMENT

(i) For a comprehensive specification for reinforcement, see CESWI 7<sup>th</sup> edition.

1. Steel reinforcement shall comply with the relevant provisions of the appropriate Standard, as set out below:

Type	Standard
Carbon steel bars	BS EN 10080 and BS 4449
Steel wires	BS EN 10080 and BS 4482
Steel fabric	BS EN 10080 and BS 4483
Stainless steel	BS 6744
Epoxy coated steel	BS ISO 14654

2. Steel fabric reinforcement shall be welded at the intersections and shall be delivered to the Site in flat sheets, except where pre-bent reinforcement is specified.

3. Steel reinforcement shall be obtained from firms holding a valid Certificate of Approval for the manufacture and/or fabrication of steel reinforcement issued by the UK Certification Authority for Reinforcing Steels or equivalent authority. The CARES, or equivalent, Certificate of Approval Number shall be stated on all appropriate purchase documentation.

#### **4.2.14 TYING WIRE**

1. Tying wire for steel reinforcement shall be 1.6 mm diameter annealed mild steel wire, complying with BS 1052.

#### **4.2.15 COVER BLOCKS AND SPACERS FOR REINFORCEMENT**

1. Cover blocks and spacers shall comply with BS 7973-1. To maintain the correct clear cover of concrete over steel reinforcement, they shall be as small as possible, consistent with their purpose.

2. Concrete cover blocks shall be manufactured with a 10 mm maximum aggregate size and otherwise produced to the same specification as the surrounding concrete. Wire cast in the block for the purpose of tying it to the reinforcement shall comply with Section 4.2.14.

3. Spacers shall be of rust-proof material and shall not produce staining or otherwise be detrimental to the concrete or steel.

#### **4.2.16 PRECAST CONCRETE PRODUCTS**

*(i) Where necessary the surface finish shall be shown on the Drawings.*

1. Constituent materials of precast concrete products shall comply with the relevant requirements of this Specification, except where an appropriate European or British Standard includes specified requirements to the contrary.

2. Except where otherwise agreed or specified in a relevant European or British Standard, the surface finish of precast concrete products shall be Rough Finish for surfaces next to earth and Fair Finish elsewhere.

#### **4.2.17 PLASTIC SHEETING AND SLEEVING**

1. Plastic sheeting for waterproof underlay shall have a composition in accordance with BS 6076.

2. The minimum nominal film thickness shall be 250 µm.

#### 4.2.18 VITRIFIED CLAY PIPES AND FITTINGS

*(i) IGN 4-11-01 deals with vitrified clay pipes and fittings.*

*(ii) The type of joint and jointing materials for extra-chemically-resistant pipes should be shown on the Drawings.*

1. Vitrified clay pipes and pipeline fittings, including extra-chemically-resistant pipes and fittings, shall comply with the relevant provisions of BS 65 or BS EN 295-1.

2. Vitrified clay jacking pipes shall conform to BS EN 295-7.

#### 4.2.19 CONCRETE PIPES AND FITTINGS

*(i) Particular requirements from the options listed in BS EN 1916 and BS 5911-1, should be described.*

*(ii) Additional protective measures required by BRE Special Digest 1 to provide resistance to the actual ACEC (Aggressive Chemical Environment for Concrete class) should be described.*

1. Unreinforced and reinforced concrete pipes and fittings shall comply with the relevant provisions of BS EN 1916 and BS 5911-1.

2. All pipes and fittings shall have gasket-type joints of spigot and socket or rebated form.

3. Unreinforced and reinforced concrete jacking pipes shall comply with the relevant provisions of BS EN 1916 and BS 5911-1. Pipes shall withstand the jacking loads to which they will be subjected during installation, without cracking or spalling. A certificate shall be supplied, confirming that the pipes are suitable for jacking and stating the distributed jacking loads for which they were designed.

#### 4.2.20 DUCTILE IRON PIPES AND FITTINGS

*(i) IGN 4-21-01 deals with ductile iron pipes and fittings.*

*(ii) IGN 4-51-01 deals with external zinc coating of ductile iron pipe, which BS EN 598 now requires on all pipes in the diameter range 80-1600 mm.*

*(iii) WIS 4-52-01 and IGN 4-52-02 deal with polymeric anti-corrosion (barrier) coatings. The thickness of the coatings should be such that the chemical-resistance test in BS EN 598, Section 5.6 is complied with.*

1. Ductile iron pipes, fittings and joints shall comply with the relevant provisions of BS EN 598.

2. Flanges for pipes and pipeline fittings shall comply with BS EN 1092-2 for ductile iron.

3. Factory-applied coatings shall be in accordance with BS ISO 8179-1. Where external zinc spray and a bituminous finishing layer are applied, this shall be in accordance with BS EN 598.

4. Factory-applied and site-applied (tubular) polyethylene sleeving shall be in accordance with BS 6076.

5. Tubular polyethylene film for use as a loose protective sleeving for buried iron pipes and fittings shall comply with the relevant provisions of BS 6076, except that the nominal layflat width shall be 280 mm for use with 80 mm and 100 mm nominal internal diameter pipelines incorporating push-in flexible joints, and 400 mm for 150 mm nominal internal diameter pipelines. Sleeving for pipes for below-ground use for potable water shall be coloured blue and all other sleeving black. Joints in sleeving shall be taped so as to form a continuous barrier and any damage to the sleeving shall be

repaired prior to backfilling.

6. Bituminous coatings shall comply with BS 3416.

#### **4.2.21 UNPLASTICISED PVC PIPES AND FITTINGS**

*(i) BS EN 1295-1 gives guidance on the structural design of underground non-pressure PVC-U pipes.*

1. Unplasticised PVC pipes, joints and fittings for gravity sewers shall comply with the relevant provisions of BS 4660 and BS EN 1401-1.

2. Solvent cements for jointing unplasticised PVC pipes shall comply with the relevant provisions of BS EN 14814. For pipes and fittings complying with BS 4660, BS EN 13598-1 or BS EN 1401-1, solvent cement may alternatively comply with BS EN 14680.

3. Solvent cements for jointing unplasticised PVC pipes shall not be used for below-ground use.

#### **4.2.22 THERMOPLASTICS STRUCTURED WALL PIPE**

1. Thermoplastics structured wall sewer pipe shall comply with the relevant provisions of BS EN 13476-1 and WIS 4-35-01 and BS EN 13476-2 or BS EN 13476-3 with the following properties:

- Maximum length of pipe for laying to be 3 m or 10 x D, whichever is the greater, unless welded joints are used;
- Pipe nominal short-term ring stiffness to be not less than 8 kN per m<sup>2</sup> for pipes less than or equal to 500 mm in diameter;
- Pipe nominal-short term ring stiffness to be not less than 2 kN per m<sup>2</sup> for pipes greater than 500 mm in diameter;
- Long-term deformation to be less than 6% of the vertical nominal pipe diameter;
- Factor of safety against buckling to be not less than 2.5;
- Pipes shall be BSi Kitemarked or have equivalent Third Party Certification.

2. Transportation, handling, storage and laying are to be in accordance with the manufacturer's recommendations.

#### **4.2.23 POLYETHYLENE PIPES AND FITTINGS**

*(i) Further guidance on the design and use of PE pipes can be found in the WRc/BPF 'Polyethylene Pipe Systems Manual' and IGN 4-32-18.*

1. Polyethylene piping systems for above-ground pressure systems for general purposes, for drainage and for sewerage shall comply with BS EN 12201-1 and BS EN 12201-2 and be coloured black. Co-extruded polyethylene pipes may be used for these purposes but shall have a black outer layer.

2. Electrofusion fittings shall comply with the relevant provisions of BS EN 12201-3.

3. All electrofusion fittings shall be of integral wire construction. All fittings shall be of an automatic type and fitted with recognition resistors, identifiable by an automatic electrofusion control box, complete with an electronic data acquisition facility for joint data analysis and quality assurance.

#### **4.2.24 GRP PIPES AND FITTINGS**

1. The use of GRP pipes and fittings shall only be permitted by agreement of Scottish Water.

#### **4.2.25 JOINT SEALS AND LUBRICANTS**

1. Elastomeric joint seals shall be Type WC or WG, complying with the relevant provisions of BS EN 681-1, and shall be obtained from the pipe manufacturer.

2. Joint lubricants for sliding joints shall have no deleterious effect on either the joint rings or pipes, and shall be unaffected by sewage.

3. Seals shall be tested in accordance with BS 7874 and shall comply with the following:

- The average loss in mass (Z) of the test pieces shall not exceed 3.5%; and
- There shall be no greater release of carbon black or other fillers from the test set than from the control set when the surface of the specimens is lightly rubbed.

4. In the case of composite seals, the requirements only apply to those components exposed to the contents of the pipeline or pipework.

#### **4.2.26 PIPE SURROUND MATERIALS**

*(i) IGN 4-08-01 gives guidance on pipe surround materials.*

*(ii) Any limitations on the size and type of materials should be described.*

1. Processed granular and “as-dug” bedding, sidefill and surround materials for buried pipelines shall comply with WIS 4-08-02.

2. Recycled materials shall comply with BS 8500-2.

#### **4.2.27 PRECAST CONCRETE SETTING BLOCKS FOR PIPES**

1. Precast concrete setting blocks for pipes shall have rectangular faces, with sufficient plan area to prevent punching of the blinding concrete or final surface, and to provide an adequate seating for the pipes. They shall be manufactured

from compressive strength C16/20 concrete using the same type of cement as in the adjacent concrete bed. Blocks shall not be used until they have achieved a cube strength of 13.5 N/mm<sup>2</sup>.

#### 4.2.28 COMPRESSIBLE FILLER AND PACKING FOR PIPELINES

1. Compressible filler for interrupting concrete protection to pipes shall consist of bitumen-impregnated insulating board to BS EN 622-1 and BS EN 622-4. The thickness of compressible filler shall be as follows:

Nominal Diameter of Pipe (mm)	Thickness of Compressible Filler (mm)
Less than 450	18
450 – 1200	36
Exceeding 1200	54

2. Compressible packing for use between pipes and precast concrete setting blocks shall consist of bitumen damp-proof sheeting complying with BS 6398.

3. Bituminous materials shall not be put into contact with plastics pipes.

#### 4.2.29 CLAY PUDDLE

1. Clay puddle shall be impervious to water and be free from sand, grit, stones and other deleterious matter.

2. The clay, on being dug, shall be exposed to the air for at least 24 hours, and thereafter, shall be worked with water into a consistency suitable for punning. A roll of clay 300 mm long and 40 mm in diameter shall support its own weight when suspended from one end.

#### 4.2.30 PRECAST CONCRETE MANHOLES

*(i) Particular requirements from the options listed in BS EN 1917 and BS 5911-3 should be detailed in the Drawings.*

*(ii) Additional protective measures required by BRE Special Digest 1 to provide resistance to the actual ACEC (Aggressive Chemical Environment for Concrete) class should be detailed in the Drawings.*

*(iii) Precast concrete*

1. Precast concrete manhole units for manholes, chambers and wet wells shall comply with the relevant provisions of BS EN 1917 and BS 5911-3. Units which bed into bases shall be manufactured so that imposed vertical loads are transmitted directly via the full wall thickness of the unit.

2. The profiles of joints between units and the underside of slabs shall be capable of withstanding applied loadings from such slabs, and spigot-ended sections shall only be used where the soffit of the slab is recessed to receive them.

3. Precast concrete chamber sections for valves and meters shall be interlocking and comply with BS EN 1917 and BS 5911-3.



manhole units of rectangular cross-section may be specified as an alternative to brickwork construction.

4. Cements are to achieve BRE Digest Class 4 sulphate resistance.

#### 4.2.31 PRECAST CONCRETE SLABS AND COVER FRAME SEATING RINGS

1. Precast concrete slabs and cover frame seating rings shall comply with the relevant provisions of BS EN 1917 and BS 5911-3.

2. Cements are to achieve BRE Digest Class 4 sulphate resistance.

#### 4.2.32 PLASTIC CHAMBERS AND RINGS

1. Plastic chambers and rings, including demarcation chambers, shall comply with BS EN 13598-1 or BS EN 13598-2.

#### 4.2.33 MANHOLE COVERS FRAMES AND INSPECTION CHAMBERS

(i) The *minimum* clear opening should comply with Scottish Water's standard for new construction. This would normally be 675 mm x 675 mm.

(ii) BS EN 124 is a *minimum performance Standard only*.

1. Manhole covers and frames shall comply with the relevant provisions of BS EN 124, BS 7903 and the 'Design Manual for Roads and Bridges: HA/104/09 Geotechnics and Drainage: Chamber Tops and Gully Tops for Road Drainage and Services: Installation and Maintenance'. They shall be of a non-rocking design which does not rely on the use of cushion inserts.

2. Manhole covers on foul-only sewers shall be of low leakage types in order to prevent excessive surface water ingress.

3. As a minimum, Class D 400 covers shall be used in carriageways of roads (including pedestrian streets), hard shoulders and parking areas used by all types of road vehicles.

4. Minimum frame depths for NRSWA road categories I to IV shall be as follows:

NRSWA Road Category	Description	Minimum Frame Depth (mm)
I	Trunk roads and dual carriageways	150
II	All other A roads	150
III	Bus services	150
IV	All other roads except residential cul-de-sacs	150
	Residential	100

5. Class B 125 shall be used in footways, pedestrian areas and comparable locations.

6. In situations where traffic loading is anticipated to be heavier than would occur on a typical residential estate distributor road (i.e., braking or turning near a junction), a higher specification (E600) shall be used.

7. All manhole covers shall be the non-ventilating type and shall have closed keyways.

#### 4.2.34 MANHOLE STEPS

*(i) Unprotected aluminium steps should not be used.*

1. Steps for manholes and other chambers shall be Type D Class 1, complying with the requirements of BS EN 13101.

2. Galvanised mild steel steps and plastic encapsulated steps are preferred.

#### 4.2.35 NON-MAN ACCESS CHAMBERS

1. Non-man access chambers shall comply with relevant provisions of BS EN 752.

#### 4.2.36 NUTS, SCREWS, WASHERS AND BOLTS

1. Nuts, screws, washers and bolts shall comply with the relevant provisions of the appropriate Standard, as follows:

Type	Standard
Metal washers for general purposes	BS 4320
ISO black bolts, screws and nuts	BS 4190
ISO precision bolts, screws and nuts	BS 3692
High-strength friction grip bolts, nuts and washers	Relevant parts of BS EN 14399
Stainless steel bolts, screws, studs	BS EN ISO 3506-1
Stainless steel nuts	BS EN ISO 3506-2

2. Bolting for pipes and fittings shall comply with the relevant provisions of BS EN 1092-2 except that spheroidal graphite iron bolts for use with ductile iron pipes and fittings shall be manufactured from metal complying with the provisions of BS EN 1563 for Grade EN-JS1050.

3. Bolt lengths and tightening torque shall be in accordance with manufacturer's recommendations and shall be sufficient

to ensure that nuts are full-threaded when tightened in their final position with two threads showing.

4. Where bolting is metallurgically incompatible with the material being fixed, the contact areas shall be isolated either by painting with an approved silicon sealant (and allowed to dry before tightening together) or with suitable isolating washers, and sleeves shall be used.

5. Washers shall be provided under the head of the bolt and under the nut.

6. Unless manufactured from stainless steel, all fasteners shall be protected against corrosion in accordance with WIS 4-52-03.

#### 4.2.37 SAFETY CHAINS

*(i) The location of safety chains should be shown on the drawings.*

*(ii) Lifting Regulations do not apply to safety chains in sewers.*

1. Mild steel safety chain shall be medium tolerance chain conforming to BS EN 818-3 Grade 4 nominal size 8 x 24. After manufacture, mild steel safety chains shall be hot-dip galvanised in accordance with BS EN ISO 1461.

2. Stainless steel safety chains shall be manufactured from Grade X5CrNiMo 17-12-2 steel conforming to BS EN 10088-3. Chain links shall be welded, and have an internal length not exceeding 45 mm and an internal width of 12 mm and 18 mm. The fins caused by welding shall be removed and the weld shall be smoothly finished all round.

3. When tested in accordance with BS EN 818-1, each chain shall withstand a breaking force of 30 kN and a proof force of 15 kN.

#### 4.2.38 HANDRAILS AND BALUSTERS

*(i) Where stainless steel tubes are to be bent to a very small radii, it may be necessary to describe their condition as GKM(S) instead of KM.*

*(ii) BS 6180 also deals with permanent protective barriers designed to resist vehicular impacts.*

*(iii) BS EN ISO 14122-3 gives guidance on the construction of guardrails.*

*(iv) Aluminium handrails and balusters should not be used in sewers, sewer manholes, sewage pumping stations or confined spaces*

1. Protective barriers shall conform to BS 6180 with loading determined from Table NA.8 from the UK National Annex to BS EN 1991-1-1.

2. Handrails and balusters shall be manufactured from materials conforming to the appropriate Standard as set out below:

	<b>Standard</b>	<b>Grade</b>
Mild steel – solid	BS EN 10025-2	S275
Mild steel – tubular	BS EN 10255	HFW2
Stainless steel – solid	BS EN 10088-3	1.4401
Stainless steel – tubular	BS EN 10296-2	LW17KM

3. GRP handrails and balusters shall be manufactured from pultruded sections conforming to BS EN 13706-2 and BS EN 13706-3. The surface shall be smooth with fibres embedded

in sewage treatment works.

(v) Any requirements for toeboards and infill panels should be described in the Agreement.

(i) BS EN ISO 14122-4 gives guidance on the construction of ladders.

(i) Sizes and types of fixings should be shown on the Drawings together with minimum requirements for edge distances, centres of fixings and embedments.

(ii) For guidance on the selection and use of fixings in concrete and masonry, see CIRIA Technical Note TN137.

(iii) BS 6180 gives recommendations for fixing protective barriers.

(iv) The safe working load should be shown on the Drawings.

(v) BS 5080-1 does not give

and sealed against penetration from dirt and water. The Barcol hardness of the sections shall be at least 35 when tested in accordance with BS 2782-10.

4. After manufacture, mild steel handrails and balusters shall be hot-dip galvanised in accordance with BS EN ISO 1461.

5. After manufacture, aluminium handrails and balusters shall be anodised in accordance with BS EN ISO 7599, Grade AA25.

#### 4.2.39 LADDERS

1. Ladders in manholes and similar structures shall comply with the requirements of BS EN 14396, with width of rung 380 mm and two stringers, but shall not be made from aluminium.

2. Mild steel ladders for vertical fixing shall be fabricated from steel conforming to BS EN 10025-2. After fabrication, low carbon steel ladders shall be hot-dip galvanised in accordance with BS EN ISO 1460.

3. Stainless steel ladders for vertical fixing shall be fabricated from Grade X5CrNiMo 17-12-2 steel conforming to BS EN 10088-3.

4. GRP ladders shall be manufactured from pultruded sections conforming to BS EN 13706-2 and BS EN 13706-3. The surface shall be smooth with fibres embedded and sealed against penetration from dirt and water. The Barcol hardness of the sections shall be at least 35 when tested in accordance with BS 2782-10.

#### 4.2.40 FIXINGS FOR METALWORK

1. Mild steel bolts and nuts shall be hot-dip galvanised in accordance with BS EN ISO 1461. Mild and high-tensile steel proprietary fixings shall be protected in accordance with the relevant provisions of the appropriate British Standard as set out in the following Table.

Type of Protection	Type of Fixing		
	Cast-in having no machined thread	Cast-in/expanding, basic major diameter machined thread	
		Not exceeding 19 mm	Exceeding 19 mm
Hot-dip galvanised	BS EN ISO 1460	-	-
Electroplated zinc	BS EN ISO 2081 Zn 10	BS 7371-12	BS EN ISO 2081 Zn 10

*recommendations for the interpretation of the results of tests for the purposes of design, selection or use of fixings.*

2. Stainless steel proprietary fixings, bolts and nuts shall be manufactured from Grade X5CrNiMo 17-12-1 steel complying with BS EN 10088.

3. Anchor bolts for fixing safety chains shall be of the stainless steel safety type which shall provide a progressive mode of failure.

4. Axial and shear loading tests on structural fixings in concrete or masonry shall be carried out in accordance with the provisions of BS 5080-1 and -2, respectively.

5. Where fixings are metallurgically incompatible with the material being fixed, suitable isolating washers and sleeves shall be used.

#### **4.2.41 BRICKS AND BLOCKS**

*(i) The term "blocks" has been used for precast concrete masonry units.*

*(ii) Bricks used in bedding to manhole covers should be bonded using high-strength mortar (such as polyester resin).*

1. Chambers shall be precast concrete masonry units, manufactured in accordance with BS 6073-2 (partially replaced by BS EN 772-2), containing a minimum of 350 kg per m<sup>3</sup> of sulphate-resisting cement and having a maximum water:cement ratio of 0.45, a minimum compressive strength of 40 N per mm<sup>2</sup>, and a maximum water absorption of 7%.

2. Clay bricks to be used in manholes and chambers shall be solid, Class B engineering bricks complying with the relevant provisions of BS EN 771-1.

3. The shapes and dimensions of special bricks shall comply with the relevant provisions of BS 4729.

4. All bricks shall have freeze/thaw designation F2.

5. All bricks shall have active soluble salts content designation S2.

#### **4.2.42 FLEXIBLE COUPLINGS**

1. Flexible couplings for gravity sewerage and drainage pipes shall comply with the provisions of WIS 4-41-01 and BS EN 295-4.

#### **4.2.43 JOINT SEALING COMPOUNDS AND SEALANTS**

*(i) Fuel-resistant types of sealants to BS EN 14188-1 or BS 5212-1 may be required where concrete surfaces are subject to fuel spillage.*

*(ii) BS 6213 gives guidance on the selection of*

1. Joint sealing compounds shall be impermeable ductile materials of a type suitable for the conditions of exposure in which they are to be placed, and capable of providing a durable, flexible and watertight seal by adhesion to the concrete throughout the range of joint movement.

2. Hot poured joint sealants shall comply with BS EN 14188-1, Type N1 sealant.

*constructional sealants.*

*(iii) CIRIA Technical Notes TN128 and TN144 deal with sealants in wet conditions.*

3. Cold poured polymer-based joint sealants shall comply with BS 5212-1, Normal Type N sealant.

4. Primers for use with joint sealants shall be compatible with, and obtained from, the same manufacturer as the adjacent sealant. Primers shall have no harmful effects on the surfaces to which the joint sealant is to be applied.

5. Sealants and primers which will be in contact with sewage shall be resistant to biodegradation.

6. Two-part, polyurethane joint sealants shall comply with the requirements of BS EN ISO 11600.

#### **4.2.44 ACCESS COVERS FOR PUMPING STATIONS**

*(i) Openings should conform to Scottish Water's requirements and be large enough to allow pumps and other equipment to be lifted safely.*

1. Covers shall be lockable, galvanised, fabricated mild steel or ductile iron.

#### **4.2.45 POLYPROPYLENE PIPES AND FITTINGS**

1. Polypropylene pipes and fittings for gravity sewers shall comply with the relevant provisions of BS EN 1852-1.

#### **4.2.46 CHEMICAL CURING AGENTS FOR CONCRETE**

1. Chemical curing agents shall be non-staining, non-toxic, have a 75% moisture retention standard and become stable and impervious to evaporation of water from the concrete within 60 minutes of application. The compound shall not react chemically with the concrete to be cured and shall not rack, peel or disintegrate within three weeks after application.

2. Testing of chemical curing agents shall comply with BS 7542.

## 4.3 EXCAVATION AND BACKFILLING

### 4.3.1 EXCAVATION

(i) The following publications give recommendations as to standards of good practice for excavation: BS 6031; BS 6164; Report R97, 'Trenching Practice', published by CIRIA; and Technical Note TN95 'Proprietary Trench Support Systems', published by CIRIA.

(ii) Excavations in carriageways should, wherever possible, be located such that the edge of the opening is at least 1 m from the edge of the carriageway.

(iii) Care should be taken when siting spoil heaps to avoid damaging trees by impinging on their root spread.

(iv) Stored excavated granular material may require draining to achieve acceptable water content.

1. Operations shall be carried out in such a manner as to prevent damage to, or deterioration of, the formations of excavations.

2. Excavations in roads and streets shall be carried out in accordance with the relevant Highway Reinstatement Specification.

3. Excavations in locations where services may be encountered shall be carried out in accordance with HSG47 'Avoiding Danger from Underground Services'.

4. Trenches shall be excavated so that the effective width is maintained within any limit imposed by the design of the pipelines. The sides of excavations shall be adequately supported at all times and, except where described in or permitted under the Contract, shall not be battered.

5. Trenches in rock for rising mains up to 100 mm nominal diameter shall be excavated to provide a minimum clearance of 100 mm around the outside of pipe barrels and joints. For pipes with nominal diameters exceeding 100 mm, the minimum clearance shall be increased to 150 mm for flexible and 200 mm for rigid pipelines.

6. If ground in the formations is encountered which is considered unsuitable, or if the formation is damaged or allowed to deteriorate, Scottish Water shall be promptly informed.

7. Soft spots shall be removed from the bottom of trenches and other excavations, which shall then be refilled to formation level with the same material as the permanent work which is to rest on that formation. Any void which results from over-excavation below formation level shall be refilled in the same manner.

8. Excavated granular material which can be reused shall be kept separate from excavated cohesive materials.

### 4.3.2 DEALING WITH WATER

(i) A Discharge Consent may be required from the Scottish Environment Protection Agency.

(ii) Pollution Prevention Guidance PPG 5 and PPG 6 published by the Scottish Environment Protection

1. Water shall not be allowed to accumulate in any part of the Works. Water arising from, or draining into, the Works shall be drained or pumped to a consented disposal point. Any drainage sumps required shall, where practicable, be sited outside the area excavated for the permanent Works, and shall be refilled with either DoT Type 1 granular sub-base material or lean concrete Grade GEN1 (C10) to the level of the underside of the adjacent permanent Works.

*Agency should be applied.*

2. All necessary precautions shall be given to prevent any adjacent ground from being adversely affected by loss of fines through any dewatering process.

3. Method statement and details of pollution prevention measures relating to the control and disposal of groundwater from de-watering operations shall be provided. Discharges to sewers shall not take place without the consent of Scottish Water.

#### **4.3.3 TEMPORARY DRAINS**

1. Where temporary drains (e.g., trench sub-drains) are required, they shall be laid in a narrow trench or grip formed below the bottom of the excavation in an approved position. The pipes shall be open-jointed and shall be surrounded with free-draining granular material (see 4.2.26).

2. When no longer required, temporary drains shall be removed or sealed.

3. When sealing temporary drains, grouting pipes shall be inserted in the line of the temporary drains at intervals not exceeding 25 m. The drains shall be solidly filled with grout (Class G3 or G4) and the grouting pipes cut off on completion of the filling. Care shall be taken to avoid impregnation of the granular bedding material around the main pipeline.

#### **4.3.4 BACKFILLING**

*(i) The Highway Authority may impose requirements for backfilling under existing highways.*

1. Backfilling shall, wherever practicable, be undertaken immediately when the specified operations preceding it have been completed. Backfilling shall not, however, be commenced until the Works to be covered have achieved a strength sufficient to withstand all loading imposed thereon.

2. Backfilling shall be undertaken in such a manner as to avoid uneven loading or damage.

3. Filling material shall be deposited in layers not exceeding 225 mm unconsolidated thickness, and then fully compacted to form a stable backfill. Where the excavation is within 1 m of the outside of the edge of the carriageway (or proposed carriageway) the fill material shall be such as to permit adequate drainage.

4. Where the excavations have been supported and the supports are to be removed, these (where practicable) shall be withdrawn progressively as backfilling proceeds, in such a manner as to minimise the danger of collapse, and all voids formed behind the supports shall be carefully filled and compacted.

5. Backfilling in roads and streets shall be filled above the level of any pipe surround required in accordance with the relevant



#### Highway Reinstatement Specification.

6. Filling material to excavations not suited in highways or prospective highways shall be placed and compacted to form a table backfill.

7. Hardcore shall consist of clean, hard, durable material uniformly graded from 200 mm to 20 mm, and be free from extraneous matter.

8. Selected fill, whether selected from locally-excavated material or imported, shall consist of uniform, readily-compactable material. Fill shall be free from vegetable matter, building rubbish and frozen material or materials susceptible to spontaneous combustion, and shall exclude clay of liquid limit greater than 80 and/or plastic limit greater than 55 and materials of excessively high moisture content, Clay lumps and stones retained on 75 mm and 37.5 mm sieves, respectively, shall be excluded from fill material.

#### **4.3.5 REINSTATEMENT OF MAINTAINABLE HIGHWAYS**

1. Reinstatement of roads and streets (including carriageways, footways, footpaths, cycle tracks and verges) which are maintainable highways shall be undertaken in accordance with the relevant provisions of the relevant Highway Reinstatement Specification.

2. Road categories and reinstatement requirements shall be obtained from the relevant Highway Authority and comply with the New Roads and Street Works Act 1991.

3. Kerbs, channels, edgings and quadrants disturbed by the Works shall be re-laid with existing units, providing they are not damaged. Where existing units are not suitable for re-use, replacement units of similar texture, colour and type, consistent with those adjacent and complying with the relevant provisions of Clause 2.98, shall be provided.

4. Kerbs, edgings, channels and quadrants shall be laid and bedded on a layer of Class M12 mortar, either on the concrete carriageway or on a GEN3 concrete foundation, as described in the Contract. They shall be butt-jointed, except where they are laid on concrete carriageways. They shall be provided with joints coincident with the carriageway movement joints, of width and with filler identical to that used in the carriageway joints. All kerbs shall be backed with GEN3 concrete.

5. In-situ kerbs and channels shall be reinstated to conform with adjoining kerbs and channels.

#### **4.3.6 REINSTATEMENT OF NON-MAINTAINABLE HIGHWAYS**

1. Non-maintainable highways shall, except where otherwise stated in the Contract, be reinstated in accordance with the relevant provisions of Clause 4.3.5.

#### **4.3.7 USING FOAMED CONCRETE**

1. Reinstatement of openings in highways and roads using foamed concrete shall comply with the British Cement Association publication 'Foamed Concrete – a Specification for Use in Reinstatement of Openings in Highways'.

2. The pipe surround material shall be protected from the foam concrete by an impermeable layer.

3. Foamed concrete may be used for filling of abandoned sewers and sewer connections, subject to the approval of Scottish Water.

#### **4.3.8 LAND DRAINS**

*(i) Any special requirements necessary to facilitate the restoration of land drainage should be described in the Contract.*

1. The positions of all land drains intercepted, disturbed or reinstated shall be prominently marked at every point of intersection with the works. Records shall be kept of positions, depths, pipe diameters and the types of construction, and a copy of these records shall be given to Scottish Water. Care shall be taken to prevent the disturbance of markers.

2. Prior to the permanent reinstatement of land drainage, existing drains, where intercepted by excavations, shall be cleared. Facilities shall be afforded to Scottish Water and the landowner or occupier to inspect them and to determine the extent of replacement that may be necessary.

3. The backfill of intercepting excavations shall be compacted in 200 mm layers, to give a firm bearing immediately before replacement pipes are laid, and shall be brought up to the level of the underside of the land drains or of any support to be provided.

4. The affected land drains shall be cut back into firm ground until, in each case, a section is exposed which is unaffected by the Works.

5. Replacement pipes or support beams shall bear on undisturbed ground for at least 500 mm at each end. The replacement pipes shall be of the same internal diameter as the sections of drain which they replace and shall be properly connected at each end. Support beams shall be of treated timber with cross-section of 150 mm x 75 mm and the replacement pipes shall be secured to the support beams with tie wire.

6. Stone drains shall be restored by using a 75 mm internal diameter (minimum) perforated pipe along the eye of the drain over the length of the disturbed section. A 150 mm stone surround of single size aggregate shall be placed around the perforated pipe wrapped in an approved geotextile to provide a drain of the same cross-section to that disturbed.

7. All culverts of whatsoever nature shall be reformed to provide a cross-section of the same cross-section to that disturbed.

#### 4.4 FORMWORK AND CONCRETE

##### 4.4.1 CONCRETE MIXES AND WORKABILITY

(i) For a comprehensive specification for reinforced concrete, see CESWI, 7<sup>th</sup> edition.

(ii) The mixes are consistent with the relevant standard mixes in BS 8500.

(iii) See 4.2.9 for the use of sulphate-resisting Portland cement.

1. Standard concrete mixes shall be in accordance with BS EN 206 and BS 8500 and shall be used with a 20 mm nominal maximum size of aggregate and a slump class S2 for a target 70 mm.

2. Suitable applications for the concrete mixes are shown in the following Table.

Standard Mix	Strength Class of Concrete	Applications
GEN1	C8/10	Fillings, blindings, soft spots and drainage sumps
GEN3	C16/20	All other applications

3. Compressive-strength testing shall not be used to judge the compliance of a concrete but, where required by Scottish Water, evidence shall be provided of the batch masses used to produce any concrete.

4. Admixtures (including calcium chloride and pigments) shall not be used in the production of concrete.

##### 4.4.2 CHLORIDE CONTENT

1. Chloride content of fresh concrete shall be determined in accordance with BS EN 206, Clause 5.2.7.

2. Methods for determining the chloride contents of constituent materials shall be in accordance with BS 8500-2, Clause 5.3.

##### 4.4.3 HIGH-STRENGTH CONCRETE TOPPING

1. High-strength concrete topping shall be produced, laid and finished in accordance with the relevant provisions of BS 8204-2 and the following approximate mix proportions by weight shall be used: one part cement, one part natural sand and two

parts single-sized coarse aggregate.

#### 4.4.4 TRANSPORTING, PLACING AND COMPACTING

*i) Attention is drawn to the recommendations in CIRIA Report R135 'Concreting Deep Lifts and Large Volume Pours' and these shall be followed, where appropriate.*

1. Concrete shall be transported from the mixer in accordance with BS 8500-2 and placed in the Works as rapidly as practicable by methods which will prevent the segregation or loss of any of the ingredients and will maintain the required consistency. It shall be deposited, as nearly as practicable, in its final position and all equipment for transporting concrete shall be kept clean.

2. Concrete shall be delivered to Site within the times specified in Clause 14.2 of BS 8500-2.

3. Concrete shall be thoroughly compacted in its final position within 30 minutes of commencing discharge. The plant used for compaction shall be operated continuously during the placing of each batch of concrete until the expulsion of air has virtually ceased, and in a manner which does not promote segregation of the ingredients.

4. Whenever vibration has to be applied externally, the design of formwork and disposition of vibrators shall be such as to ensure efficient compaction and to avoid surface blemishes.

#### 4.4.5 CONCRETING IN COLD WEATHER

*(i) For further information see 'Winter Concreting' published by Concrete Information Ltd in 1985.*

1. Concreting at ambient temperatures below 2°C may be carried out only if all of the following conditions are met:

- a) the aggregates and water used in the mix shall be free from snow, ice and frost;
- b) before placing concrete, the formwork, reinforcement and any surface with which the fresh concrete will be in contact shall be free from snow, ice and frost and be at a temperature above 0°C;
- c) the initial temperature of the concrete at the time of placing shall be at least 5°C as defined in BS EN 206, Section 5.2.8, Lower Limit;
- d) the temperature at the surface of the concrete shall be maintained at not less than 5°C at any point until the concrete reaches a strength of 5 N per mm<sup>2</sup>, as confirmed by tests on cubes matured under similar conditions; and
- e) temperatures at the surface of the concrete shall be measured where the lowest temperature is expected.

2. Precautions shall be taken to prevent the temperature of any concrete falling to 0°C during the first 5 days after placing.

#### 4.4.6 CURING

1. Curing of concrete shall be carried out in accordance with BS EN 13670 curing class 2.

2. In cold weather, when the temperature of freshly-placed concrete may approach 0°C, water curing shall not be employed.

3. Components which are intended to have a similar exposed surface finish shall be cured in the same manner.

#### **4.4.7 CONSTRUCTION OF FORMWORK**

*(i) BS 5975 gives recommendations as to standards of good practice in formwork construction.*

1. Formwork shall be sufficiently rigid and tight to prevent loss of mortar matrix from the concrete, and to maintain the correct position, shape and dimensions of the finished work. Formwork shall be so constructed as to be removable from the cast concrete without shock or damage.

#### **4.4.8 CLEANING AND TREATMENT OF FORMS**

1. The interiors of all forms shall be thoroughly cleaned out before any concrete is placed. The faces of the forms in contact with the concrete shall be clean and treated with a suitable release agent, where applicable.

#### **4.4.9 STRIKING OF FORMWORK**

1. Formwork shall be removed without shock to, or disturbance of, the concrete.

2. Formwork to vertical surfaces or sloping formwork not supporting concrete in flexure shall not be removed until the concrete strength shall be sufficient to meet any wind loading upon the concrete likely to arise at the time when the formwork is removed and the concrete strength (as confirmed by tests in cubes cured under representative conditions) has reached 5 N/mm<sup>2</sup>.

3. Formwork supporting concrete in flexure shall not be removed until the concrete strength (as confirmed by tests on cubes cured under representative conditions) has reached 10 N/mm<sup>2</sup>, or twice the stress to which the concrete will then be subjected, whichever is the greater.

4. For concrete containing cement not conforming to BS EN 197, the times for striking of formwork shall be derived from CIRIA Report R136 'Formwork Striking Times - Criteria, Prediction and Methods of Assessment'.

5. Sufficient records to identify the time from pouring of any section to the striking of the formwork on the same shall be maintained on-site for inspection.

#### **4.4.10 CUTTING AND BENDING OF REINFORCEMENT**

1. Cutting and bending of reinforcement shall be in accordance with BS 8666 and shall be done without the application of heat,

in a temperature of not less than 5°C. Bends shall have a substantially constant curvature.

2. Reinforcement shall not be straightened or re-bent without the agreement of Scottish Water. If permission is given to bend projecting reinforcement, care shall be taken not to damage the concrete and to ensure that the radius is not less than the minimum specified in BS 8666.

#### **4.4.11 FIXING OF REINFORCEMENT**

1. Reinforcement shall be firmly supported in position and secured against displacement, in accordance with BS 7973-2.

2. Non-structural connections for the positioning of reinforcement shall be made with tying wire or other fixing devices. Projecting ends of ties or clips shall not encroach into the concrete cover.

3. Concrete cover shall not be less than the nominal cover minus 10 mm or greater than the nominal cover plus 15 mm ( $\Delta c$  in BS 8500-1 A3). Unless shown otherwise on the Drawings, nominal cover shall be:

- a) 45 mm for tops of walls;
- b) 50 mm for concrete cast against blinding;
- c) 75 mm for concrete cast against soil; and
- d) 40 mm for all other locations.

#### **4.4.12 SURFACE CONDITION OF REINFORCEMENT**

1. Concrete shall not be placed until reinforcement is free from any substance which might adversely affect the steel or concrete chemically, or reduce the bond.

#### **4.4.13 LAPS AND JOINTS**

1. Laps and joints in reinforcement shall be made only at the positions described on the Drawings.

#### **4.4.14 BUILT-IN ITEMS**

1. Where pipes, sleeves, water bars or other items are built into concrete, they shall be rigidly secured in position to prevent movement and shall be free from external coatings which might adversely affect the bond.
2. Precautions shall be taken to prevent the formation of air pockets, voids or other defects whilst the concrete is being placed. When specifying a standard mix, the concrete shall be classed as reinforced if items are to be built into it.

#### **4.4.15 CONSTRUCTION JOINTS**

*(i) The Drawings should show the construction joints in the positions shown in the Figures included in this Specification.*

1. Unless these are to be located in the positions shown on the typical detail Drawings the positions and details of any construction joints shall be agreed with Scottish Water before work is commenced.
2. Concreting shall be carried out continuously up to construction joints.

#### **4.4.16 SURFACE FINISHES PRODUCED WITHOUT FORMWORK**

1. The concrete shall be levelled and screeded to produce a uniform plain or ridged surface, as required. No further work shall be applied to the surface unless it is a first stage for a wood float or steel trowel finish.
2. The screeded finish shall be wood floated under light pressure to eliminate surface irregularities.
3. When the moisture film has disappeared and the concrete has hardened sufficiently to prevent laitance from being worked to the surface, the surface to the wood float finish shall be steel trowelled under firm pressure to produce a dense, smooth, uniform surface free from trowel marks.
4. Where the type of finish is not given, it shall be screeded plain.
5. Any remedial work, including rubbing down and filling in which is required to achieve the Fair and Fair Worked finishes, shall be completed when the concrete is green and before the application of any curing compounds.

#### **4.4.17 SURFACE FINISHES PRODUCED WITH FORMWORK**

1. Rough finish shall be used for surfaces which will not be visible on completion and shall be obtained by the use of moulds or properly-designed forms. The surface shall be free from substantial voids, honeycombing or other large blemishes.
2. Fair finish shall be used for surfaces which will be visible on completion and shall be obtained using forms designed to produce a hard, smooth surface with true, clean arises. Only very minor surface blemishes will be permitted. Fins and other projections shall be removed and the surface made good.
3. Any remedial work, including rubbing down and filling in which is required to achieve the Fair and Fair Worked finishes, shall be completed when the concrete is green and before the application of any curing compounds.

#### **4.4.18 WEARING SCREEDS**

1. Wearing screeds (granolithic finish) shall be provided, laid and finished in accordance with the relevant provisions of BS 8204-2.
2. Wearing screeds shall provide abrasion resistance to class AR4/WS of Table 4 of BS 8204-2. Where high abrasion conditions are expected, wearing screeds shall provide abrasion resistance to class AR1/WS of Table 4 of BS 8204-2.
3. Where concrete benching is required to have a granolithic finish with abrasion resistance to class AR4/WS of Table 4 of BS 8204-2, this shall be formed with four parts 8 mm to dust to one part sulphate-resisting cement placed with a steel trowel finish. Where sulphate-resisting cement is unavailable, then a combination of Portland cement (CEM 1) and ggbs or pfa shall be used to give equivalent resistance to sulphate attack.

#### **4.4.19 TIE BOLTS FOR FORMWORK**

1. Tie bolts shall be of the high tensile variety, fixed perpendicular to the formwork.
2. Tie bolts shall not embed any permanent metal parts within 50 mm of the concrete surface.
3. Voids remaining after the removal of all, or part, of each tie bolt shall be filled flush with the surrounding concrete using a freshly-prepared cement and fine aggregate paste. All such voids shall be prepared by removing surface laitance prior to filling to ensure bond is achieved.
4. Tie bolts which form a continuous hole through a structure designed to retain an aqueous liquid will not be used.
5. In the case of structures designed to retain an aqueous liquid,



any other measures securing formwork shall not impair the watertightness of the structure or lead to corrosion of the tie bolts.

## **4.5 CONSTRUCTION OF GRAVITY SEWERS AND RISING MAINS**

### **4.5.1 GENERAL CONSTRUCTION**

(i) *The following publications give recommendations on standards of good practice for the installation of pipelines on land:*

*BS 5955-6 'Plastics Pipework (thermoplastics materials): Code of Practice for the Installation of Unplasticized PVC Pipework for Gravity Drains and Sewers';*

*'Principles of Laying Sewers', is a guide to good site practice available from Water UK;*

*BS EN 1610 'Construction and Testing of Drains and Sewers'; and*

*BS 8000-14 'Workmanship on Building Sites. Code of Practice for Below Ground Drainage'*

1. Where socketed pipes are required to be laid on a granular or sand bed, or directly on a trench bottom, joint holes shall be formed in the bedding material or excavated formation to ensure that each pipe is uniformly supported throughout the length of its barrel and to enable the joint to be made.

2. Pipes shall be laid on setting blocks only where a concrete bed or cradle is used.

3. Where pipes are required to be bedded directly on the trench bottom, the formation shall be trimmed and levelled to provide even bedding of the pipeline and shall be free from all extraneous matter that may damage the pipe, pipe coating or sleeving.

4. Pipes and fittings shall be examined for damage and the joint surfaces and components shall be cleaned immediately before laying.

5. Suitable measures shall be taken to prevent soil or other material from entering pipes, and each pipe shall be anchored to prevent flotation or other movement before the Works are complete.

6. Non-degradable marker tape shall be laid between 100 mm and 300 mm above the pipe. Where a tracer system is specified, it shall be continuous and adequately secured to valves and fittings.

7. Where the gradient of the as-laid pipeline exceeds 5%, installation shall be uphill with sockets leading.

### **4.5.2 PIPE BEDDING**

(i) *IGN 4-08-01 gives guidance on pipe surround materials.*

(ii) *Geotextile membranes may be an acceptable alternative to the use of clay stanks.*

(iii) *Full bed and surround may not be required for rigid, large diameter pipes. Reference should be made*

1. Bedding for pipes shall be constructed by spreading and compacting granular bedding material over the full width of the pipe trench. After the pipes have been laid, additional granular material shall, if required, be placed and compacted equally on each side of the pipes and, where practicable, this shall be done in sequence with the removal of the trench supports.

2. Where (in the opinion of Scottish Water) the flow of groundwater is likely to transport fine soil particles, water stops of puddle clay extending up through the bedding and sidefill shall be placed across the trench and immediately downstream

to the manufacturer's instructions.

(iv) When puddled clay stanks are required, these should be described in the Contract.

(v) Details of pipe bedding, surround and sidefill should be described in the Contract.

(vi) Refer to BS EN 1295-1 for pipe bedding design details.

(i) Rapid hardening cement should not be used in concrete for the protection of plastics pipes.

(ii) Plastics pipes should be wrapped in a layer of plastic sheeting complying with 4.2.17 before being surrounded with concrete.

(i) Further guidance is available in BS EN 1295-1.

(ii) The minimum side gaps for narrow trenching techniques are stated for compaction purposes.

(i) Proprietary joints are required to be made in accordance with the manufacturer's instructions.

(ii) The remaining flexibility

of any temporary works.

3. In bad ground conditions where the migration of the pipe granular surround into the ground may occur, the surround shall be wrapped in geotextile membrane (see BS 9295).

#### **4.5.3 CONCRETE PROTECTION TO PIPES**

1. Pipes to be bedded on, or cradled with, concrete shall be supported on precast concrete setting blocks, the top face of each block being covered with two layers of compressible packing in accordance with 4.2.27.

2. Concrete provided as a protection to pipes shall be Grade GEN3 (C/16/C20), placed to the required depth in one operation.

3. Where pipes with flexible joints are used, concrete protection shall be interrupted over its full cross-section at each pipe joint by a shaped compressible filler.

4. Where pipes are protected by a concrete cover slab placed above the pipe, this shall span the pipe trench and extend a minimum of 300 mm both sides, widening the trench above the pipe surround, and there shall be a minimum of 150 mm of surround between the crown of the pipe and underside of the slab, together with a layer of compressible material isolating the slab from the surround material.

#### **4.5.4 PIPE SURROUND**

1. Pipe surround material shall, where required, be placed and compacted over the full width of the trench in layers not exceeding 150 mm before compaction, to a finished thickness of 300 mm above the crown of the pipes.

2. Subsequent backfilling shall then be carried out as specified in 4.3.4.

#### **4.5.5 PIPE JOINTING GENERALLY**

1. Pipe jointing surfaces and components shall be kept clean and free from extraneous matter until the joints have been made or assembled. Care shall be taken to ensure that there is no ingress of grout or other extraneous material into the joint

*is required for any subsequent settlement or ground movement.*

annulus after the joint has been made.

2. Where, with the agreement of Scottish Water, rising mains are laid to curves, the deflection at any pipe joint as-laid shall not exceed three-quarters of the maximum deflection recommended by the manufacturer.

3. Site fusion jointing in polyethylene pressure pipelines shall be undertaken in accordance with the relevant provisions of WIS-4-32-08.

4. Where PE pipes are used, a fully welded system shall be used. Mechanical or electrofusion joints shall not be used.

5. Joints shall be made in accordance with the manufacturer's instructions.

6. Welds in polyethylene pipes shall be sampled as directed, and shall meet the requirements of the PE tensile weld test as described in WIS 4-32-05 Appendix G.

#### **4.5.6 CUTTING PIPES**

1. Pipes shall be cut in accordance with the manufacturer's recommendations to provide a clean square profile without splitting or fracturing the pipe wall and causing minimal damage to any protective coating. Where necessary, the cut ends of pipes shall be formed to the tapers and chamfers suitable for the type of joint to be used.

2. Where ductile iron pipes are to be cut to form non-standard lengths, the manufacturer's recommendations in respect of ovality correction and tolerances to the cut spigot end shall be complied with.

3. Where concrete pipes are cut, any exposed reinforcement shall be sealed with an epoxy resin mortar.

4. Pre-stressed concrete pipes shall not be cut on-site.

5. Particular safety precautions shall be taken to avoid inhalation of dust when cutting asbestos-cement pipes.

#### **4.5.7 THRUST BLOCK**

*(i) Thrust blocks should either be shown on the Drawings or constructed in accordance with Scottish Water's instructions on-site.*

*(ii) Plastics pipes should be separated from thrust blocks by plastic sheeting so as to minimise the risk of stress concentrations and abrasion where the pipe*

1. Except where self-anchoring joints are used, thrusts from bends and branches in rising mains shall be resisted by GEN3 concrete thrust blocks, cast in contact with undisturbed ground.

2. Any additional excavation required to accommodate thrust blocks shall be carried out after the bend or branch is in position, and the thrust face shall be trimmed back to remove all loose or weathered material immediately prior to concreting.

3. Thrust blocks shall be allowed to develop adequate strength

*emerges from the thrust block.*

before any internal pressure is applied to the pipeline.

4. Rapid hardening cement shall not be used in concrete for thrust blocks to plastics pipes.

5. Plastics pipes shall be wrapped with three layers of plastic sheeting, complying with 4.2.17.2, before being surrounded by concrete.

6. The depth of the cover to concrete blocks shall not be less than 600 mm, unless otherwise stated in the Contract.

#### **4.5.8 CONNECTIONS TO GRAVITY SEWERS**

1. Where junction pipes for future connections are required, they shall be inserted, as necessary, during construction of the sewers, and the ends of connections and pipes not needed for immediate use shall be effectively sealed with a plug. The position of all junctions shall be recorded by measurement from the centre of the manhole cover immediately downstream, and notified to Scottish Water before backfilling is carried out.

2. Connections shall be made using standard preformed junctions, where possible. Saddle connections to existing sewers shall only be allowed when the internal diameter of the major pipe is at least 150 mm greater than the internal diameter of the branch pipe.

3. Pipe saddles for concrete or clay sewers shall be bedded in Class M1 mortar and a mortar fillet formed to give a cover of at least 50 mm to the base of the saddle.

4. Where connections are to be made to pipes that require the pipe to be cut, the hole shall be of the correct size for the saddle using a trepanning cutting machine.

#### **4.5.9 TOLERANCES IN GRAVITY SEWERS AND RISING MAINS**

*(i) Lines and levels for sewers, lateral drains and rising mains should be as shown on the Drawings.*

1. The line and level of any pipeline shall not deviate from the line and level shown on the drawings, or agreed variation, by more than 20 mm and any combinations of such deviations shall not create a reverse gradient.

2. The joint displacement, being the difference in the level or alignment between the adjacent ends of two adjoining pipes at a joint, shall not exceed the least of 5% of the nominal diameter of the pipe or 20 mm.

3. The angular displacement of a joint, being the difference in the alignment of two adjacent pipes, shall not exceed 2°, except where the joint has been specifically designed and manufactured to accommodate a larger displacement.

4. Flexible pipes shall have a limit of 6% deformation.

## **4.6 CONSTRUCTION OF MANHOLES, CHAMBERS (INCLUDING NON-MAN ACCESS CHAMBERS) AND WET WELL**

### **4.6.1 BRICKWORK AND BLOCKWORK**

*(i) The term “blocks” has been used for precast concrete masonry units (see 4.2.41).*

*(ii) Flush pointing is described in BS 1996-1-2, BS EN 1996-2 and BS EN 1996-3.*

1. Brickwork and blockwork construction shall comply with the relevant provisions of BS EN 1996-1-2, BS EN 1996-2 and BS EN 1996-3.

2. Brickwork and blockwork shall be built in English bond. Bricks and blocks shall be set in mortar with all bed and vertical joints filled solid. Exposed work shall be flush pointed as the work proceeds.

3. The moisture content of the bricks and blocks shall be adjusted so that excessive suction is not exerted on the mortar.

4. Bricks and blocks in each course shall break joint correctly with the bricks/blocks underneath. The courses shall be laid parallel, with joints of uniform thickness, and shall be kept straight or regularly curved, as required. Brickwork and blockwork shall be gauged to rise 300 mm in four courses. Vertical joints shall be in alignment, as required by the bond, and shall have an average thickness of 10 mm. Bricks and blocks forming reveals and internal and external angles, shall be selected for squareness and built plumb. Bricks with single frogs shall be laid frog upwards.

5. Brickwork and blockwork shall rise uniformly. Corners and other advanced work shall be raked back and not raised above the general level more than 1 m. No brickwork or blockwork shall be carried up higher than 1.5 m in one day. No bats or broken bricks and blocks shall be incorporated in the work unless essential for bond. Where cuts to blocks are required, all cutting shall be carried out with a mechanical cutting disc.

6. Completed brickwork and blockwork shall be protected at all times from scaffold splash, mortar droppings, grout leakage from suspended slabs and the harmful effects of weather. Brickwork and blockwork shall be allowed to set thoroughly hard before cutting or chasing is carried out.

7. Mortar for brickwork below DPC shall be Class M1, and above DPC shall be Class M3.

### **4.6.2 CORBELLING**

1. Oversail corbelling shall not exceed 30 mm on each course.

### **4.6.3 BRICKLAYING AND BLOCKLAYING IN COLD WEATHER**

1. Materials used in bricklaying and blocklaying shall be frost-

free, and no bricks or blocks shall be laid when the ambient temperature is below 3°C, unless special precautions are taken. Completed work shall be protected adequately during cold weather.

2. General working practices shall be in accordance with the Brick Development Association publication 'Bricklaying in Winter Conditions', 1986.

#### **4.6.4 PRECAST CONCRETE MANHOLES, CHAMBERS AND WET WELL**

1. Where steps, ladders and slabs are used in precast concrete chamber and shaft, they shall be aligned correctly.

2. The jointing material for precast units shall be mortar, proprietary plastomeric or elastomeric seal with load bearing distribution, with the concrete surfaces prepared in accordance with the manufacturer's recommendations.

3. Joints shall be made so that the required jointing material fills the joint cavity. Concrete to concrete contact across the joint shall not be permitted. Any surplus jointing material which is extruded inside the manhole, chamber or wet well shall be trimmed off and joints shall be pointed on completion.

4. Where manholes are to have concrete surround, the concrete shall not be less than Grade GEN3 and the height of each concrete pour shall not exceed 2 m. Each construction joint shall break joint with that of the chamber or shaft sections by at least 150 mm.

5. Holes required in precast concrete chamber units to allow pipework to pass through shall be made in-situ, and oversized by the minimum amount required to ensure a watertight seal around the pipe by pre-drilling around their perimeters. Any overbreak of holes shall be made good using a mortar suitable for the pipe material.

6. Cements are to achieve BRE Digest Class 4 Sulphate Resistance.

#### **4.6.5 IN-SITU INVERTS AND BENCHINGS**

*(i) See 4.4.17 for details of surface finishes.*

1. Where a wearing screed is required, it shall have a smooth, high-strength concrete topping applied with a steel trowel before the concrete has set.

2. Inverts and benchings in manholes, chambers and the wet well shall have a screeded, ridged finish.

#### **4.6.6 PIPES AND JOINTS ADJACENT TO STRUCTURES**

*(i) Where a pipeline is to be constructed in ground which is variable or unstable, it*

1. Where rigid pipes are used, a flexible joint shall be provided as close as is feasible to the outside face of any structure into

may be appropriate for multiple rocker pipes to be provided to accommodate the anticipated differential settlement.

(ii) If flexible pipes are being used, rocker pipes are not needed.

which a pipe is built within 150 mm for pipe diameters less than 300 mm. The design of the joints shall be compatible with any subsequent movement.

2. The length of the next pipe (rocker pipe) away from the structure shall be as shown in the following Table.

Nominal Diameter (mm)	Effective Length (m)
150 to 600	0.6
over 600 to 750	1.0
over 750	1.25

3. Stub pipes into structures shall be of rigid material.

#### 4.6.7 SETTING MANHOLE COVERS AND FRAMES

1. Manhole frames shall be set to level, bedded and haunched externally over the base and sides of the frame in mortar, in accordance with the manufacturer's instructions. The frame shall be seated on at least two courses of Class B Engineering bricks, on precast concrete masonry units or on precast concrete cover frame seating rings to regulate the distance between the top of the cover and the top rung to no greater than 675 mm. A mortar fillet shall be provided where the corners to an opening in a slab are chamfered and the brickwork is not flush with the edges of the opening.

2. Frames for manhole covers shall be bedded in a polyester resin bedding mortar in all situations where covers are sited in NRSWA Road Categories I, II or III (i.e., all except residential cul-de-sacs).

#### 4.7 CLEANSING AND TESTING

##### 4.7.1 CLEANSING OF GRAVITY SEWERS AND MANHOLES

(i) The action to be taken in the event of failure to satisfy the tests specified has only been referred to in general terms where the text so requires (see also 4.1.3).

1. On completion of construction, internal surfaces of sewers and manholes and other access points shall be thoroughly cleansed to remove all deleterious matter, without such matter being passed forward into existing public sewers or watercourses. The sewers and manholes shall be maintained in a clean and serviceable condition until they are vested as public sewers.

##### 4.7.2 PRECAUTIONS PRIOR TO TESTING RISING MAINS

(i) Testing against a closed valve in a rising main should not be permitted if there is any other alternative.

1. Before testing any rising main, it shall be ensured that it is anchored adequately and that thrusts from bends, branch outlets or from the pipeline ends are transmitted to solid ground or to a suitable temporary anchorage.

(ii) For notification of

intention to test, see 4.1.4.2.  
 (iii) See also 4.5.7.

2. Open ends shall be stopped with plugs, caps or blank flanges properly jointed.
3. Testing against closed valves shall not be permitted.

#### 4.7.3 TESTING OF GRAVITY SEWERS

(i) Visual examination may include the use of CCTV and/or light-ring inspections.

1. Non-pressure pipelines laid in open cut shall be tested after they are jointed and before any concreting or backfilling is commenced, other than such as may be necessary for structural stability whilst under test.
2. Sewers up to and including 750 mm nominal diameter shall be tested by means of an air or water test.
3. An air test shall be carried out after the backfilling is complete.
4. The pipelines shall be tested by means of a visual or closed-circuit television (CCTV) examination, in lengths determined by the course of construction, in accordance with the programme. For flexible pipes, the CCTV examination shall use light rings to measure deformations.

#### 4.7.4 AIR TEST FOR GRAVITY SEWERS

(i) BS EN 1610 'Construction and Testing of Drains and Sewers' gives advice on testing requirements.

1. Non-pressure pipelines to be air tested, shall have air pumped in by a suitable means until a pressure of 100 mm head of water is indicated in a U-tube connected to the system. The pipeline shall be accepted if the air pressure remains above 75 mm head of water after a period of minutes given in the following Table without further pumping, following a period for stabilisation.

Nominal Diameter	Testing Time (Minutes)
DN 100	5
DN 200	5
DN 300	7
DN 400	10
DN 600	14
DN 800	19
DN 1000	24

2. Failure to pass the test shall not preclude acceptance of the pipeline if a successful water test can subsequently be carried out in accordance with 4.7.5.

#### 4.7.5 WATER TEST FOR NON-PRESSURE PIPELINES

(i) The allowable quantity of water added is stipulated in Clause 13.3 of BS EN 1610.

1. The test pressure for non-pressure pipelines, up to and including 1000 mm nominal bore, shall be not less than 1.0 m head of water above the pipe soffit or groundwater level



(whichever is the higher at the highest point) and not greater than 5 m head at the lowest point of the section. Steeply-graded pipelines shall be tested in stages in cases where the maximum head, as stated above, would be exceeded if the whole section were tested in one length.

2. The pipeline shall be filled with water and a minimum period of one hour shall be allowed for absorption, following which the original water level shall be restored. Water shall then be added from a measuring vessel at intervals of 5 minutes over a 30-minute period and the quantity required to maintain the original water level noted. The length of pipeline shall be accepted if the quantity of water added in 30 minutes does not exceed 0.15 litres/m<sup>2</sup> for pipelines or 0.2 litres/m<sup>2</sup> for pipelines and manholes tested together, where m<sup>2</sup> refers to the total area of the wetted internal surface.

3. Notwithstanding the satisfactory completion of the above test, if there is any discernible leakage of water from any pipe or joint, the pipe shall be replaced and/or the joint remade, as appropriate, and the test repeated until leakage is stopped.

#### 4.7.6 VISUAL INSPECTION OF GRAVITY SEWERS

(i) A visual survey may include the use of CCTV and/or internal survey, or walk-through inspection.

(ii) The ratio described in 4.7.6.2 can be written in shorthand as:

$$\frac{\emptyset \text{ max} - \emptyset \text{ mean}}{\emptyset \text{ mean}}$$

1. A visual survey shall be carried out by a qualified and approved contractor, and in accordance with the 'Model Contract Document for Sewer Condition Inspection', 2<sup>nd</sup> edition.

2. Light-ring survey equipment shall be calibrated to measure the cross-sectional dimensions and the pipe ovality to within  $\pm 1\%$ , where ovality is defined as the ratio between the difference between the maximum internal diameter and the mean internal diameter, and the mean internal diameter.

#### 4.7.7 INFILTRATION

(i) The permissible infiltration is the same as the permissible loss in the water test in 4.7.5.

(ii) Infiltration rate is based on the  $0.15\pi$  calculation included in BS EN 1610.

1. Non-pressure pipelines and manholes shall be inspected and tested for infiltration after backfilling. All inlets to the system shall be effectively closed and any residual flow shall be deemed to be infiltration.

2. The pipeline and manholes shall be accepted as satisfactory if the infiltration, including infiltration into manholes, in 30 minutes does not exceed 0.2 litres/m<sup>2</sup>, where m<sup>2</sup> refers to the total internal surface area of the pipeline, including manholes.

3. Notwithstanding the satisfactory completion of the above inspection or test, if there is any discernible flow of water entering the sewers or manholes which can be seen either by visual or CCTV inspection, such measures as are necessary to stop such infiltration shall be taken.

#### 4.7.8 WATERTIGHTNESS OF MANHOLES, CHAMBERS

## AND WET WELL

1. Manholes and chambers shall be subsequently watertight, with no discernible flow of water penetrating the Works.

### 4.7.9 TESTING OF DUCTILE IRON, PVC, GRP AND STEEL PRESSURE PIPELINES

*(i) This Section is intended for application to rising mains' materials such as ductile iron and PVC-U.*

*(ii) A large-diameter pressure gauge has been specified to enable a small change in pressure to be accurately measured.*

*(iii) Details for site pressure testing in accordance with BS EN 805 are provided in 'A Guide to Testing of Water Supply Pipelines and Sewer Rising Mains', published by WRc plc.*

1. The entire pipeline shall be pressure tested in accordance with BS EN 805 or IGN 4-01-03.

2. Rising mains shall be tested after they are jointed and before any concreting or backfilling is commenced, other than such as may be necessary for structural stability whilst under test.

3. Gauges used for testing pressure pipeline rising mains shall either be of the conventional circular type, not less than 200 mm diameter, calibrated in metres of head of water, or shall have a digital indicator capable of reading increments of 0.1 m head. Before any gauge is used, it shall be checked independently and a dated certificate of its accuracy shall be provided.

4. Before testing, valves shall be checked and sealed, the sections of main filled with water and the air released. After having been filled, pipelines shall be left under normal operating pressure for 24 hours, so as to achieve conditions as stable as possible for testing.

5. The permissible loss shall not exceed 2 litres per metre nominal bore per kilometre length per metre head (calculated as the average head applied to the section) per 24 hours.

6. The developer shall provide, and subsequently dispose of, the water required for the test. Discharges to sewers shall not take place without the consent of Scottish Water.

7. Test pressures for rising mains shall be 1.5-times the maximum operating pressure at the lowest point of the main, or the maximum operating pressure plus the maximum calculated surge pressure, whichever is the greater.

8. Where a new pipeline is to connect to an operational pipeline, the final connection shall be inspected visually under normal operating pressure and there shall be no visible leakage.

9. No testing against closed valves or existing pipelines shall be undertaken unless written permission is obtained.

10. Where the pipelines are filled with water from an existing water main, the maximum rate of filling will be as required by Scottish Water.

11. All pressure testing shall be carried out using data loggers with print out facilities.

### 4.7.10 TESTING OF POLYETHYLENE PRESSURE

## PIPELINES

1. The testing of polyethylene pressure pipelines shall be carried out in accordance with the procedures in IGN 4-01-03 'Field Pressure Testing of Pressure Pipes and Fittings for Use by Public Water Suppliers'.

### 4.7.11 TESTING OF NON-CONCRETE STRUCTURES FOR RETAINING AQUEOUS LIQUIDS

*(i) The method for assessing the change in water level should be agreed with Scottish Water, together with a reasonable interpretation of "no discernible change".*

*(ii) Rainfall and evaporation can be assessed by using a test tank of a similar size.*

1. After cleaning, and before any external fill is placed against the structure, it shall be filled to its overflow level at a rate approved by the manufacturer or detailed in the Contract. The water level shall then be recorded for a period of 3 days. The tank shall be deemed to have passed the test if there is no discernible change in water level after taking account of rainfall and evaporation, and that there are no visible signs of leakage from the walls or base of the structure.

2. This test shall be only carried out after a successful test of any roof structure.

3. Adjacent internal compartments within a structure shall be tested sequentially. Compartments adjacent to the compartment under test shall be empty during the test. Where there may be different top water levels between internal chambers or on different sides of division walls within a structure (in addition to the individual hydraulic test on chambers) the whole structure shall be tested hydraulically if not otherwise confirmed by testing of the compartments.

4. On satisfactory completion of the test, the structure shall be emptied as far as practicable, unless the water can be used as part of subsequent activities.

# APPENDICES

# APPENDIX I – PUBLICATIONS

NOTE: The documents in this list are referenced in Sewers for Scotland.

## A. GENERAL

Number	Title	Published by/ Date	Reference
HSG47	Avoiding Danger from Underground Services, 3 <sup>rd</sup> edition	HSE, 2014	4.3.1
	BRE Special Digest 1 Concrete in Aggressive Ground	BRE, 2005	Figure 13, Figure 14, 2.26.4, 4.2.8, Figure 22, 4.2.19, Figure 25, 4.2.30
	Bricklaying in Winter Conditions	Brick Development Association, 1986	4.6.3
Report R59	Building Sands: Availability, Usage and Compliance with Specification Requirements	CIRIA, 1976	4.2.6
Technical Note TN128	Civil Engineering Sealants in Wet Conditions – Review of Performance and Interim Guidance on Use	CIRIA, 1987	4.2.43
	Civil Engineering Specification for the Water Industry (CESWI, 7 <sup>th</sup> edition)	UKWIR Ltd/WRc plc, 2011	4.2.8, 4.4.1, Appendix VI
Report R135	Concreting Deep Lifts and Large Volume Pours	CIRIA, 1995	4.4.4
	Delivering Sustainable Flood Risk Management: Document Guidance	Scottish Government, 2011	2.9.6
	Drainage Assessment: A Guide for Scotland	SEPA, 2005	1.3, 2.3, 2.7.1
	Drainage of Development Sites – a Guide (X108)	CIRIA, 2004	2.7.1
IET Guidance Note 8	Earthing and Bonding, 2 <sup>nd</sup> edition	IET, 2011	3.13.8.1
	Flood Estimation Handbook	Centre for Ecology & Hydrology, 1999	2.6
Report No. 124	Flood Estimation for Small Catchment	Centre for Ecology & Hydrology), 1994	2.7.1, Appendix VII
	Foamed Concrete – a Specification for Use in Reinstatement of Openings in Highways	British Cement Association, 1993	4.3.7
Report R136	Formwork Striking Times - Criteria, Prediction and Methods of Assessment	CIREA, 1995	4.4.9
	Design Manual for Roads and Bridges: HA/104/09 Geotechnics and drainage: Drainage: Chamber Tops and Gully Tops for Road Drainage and Services: Installation and Maintenance	Highways Agency, 2009	4.2.33
	General Binding Rules 10 and 11	SEPA	1.3, 2.7

<b>Number</b>	<b>Title</b>	<b>Published by/ Date</b>	<b>Reference</b>
IET Guidance Note 3	Inspection and Testing, 6 <sup>th</sup> edition	IET, 2011	3.10.1
	Model Contract Document for Sewer Condition Inspection, 2 <sup>nd</sup> edition	WRc plc, 2005	4.7.6
Technical Note TN144	Performance of Sealant-Concrete Joints in Wet Conditions: Results of a Laboratory Testing Programme: Volume 1: Main Results and Discussion	CIRIA, 1992	4.2.43
PAN 61	Planning Advice Note PAN 61: Planning and Sustainable Urban Drainage Systems	Scottish Executive, 2001	2.1, 2.7.1, 2.9.10
PAN 69	Planning Advice Note PAN 69: Planning and Building Standards Advice on Flooding	Scottish Executive, 2004	2.7.1, Appendix VIII
	Principles of Laying Sewers	Water UK	4.5.1
Technical Note TN95	Proprietary Trench Support Systems, 3 <sup>rd</sup> edition	CIRIA, 1986	4.3.1
IET Guidance Note 5	Protection Against Electric Shock, 6 <sup>th</sup> edition	IET, 2012	3.13.8.1
	Regulatory Method (WAT-RM-08): Sustainable Urban Drainage Systems (SUDS or SUD systems)	SEPA, 2014	2.2.6
SPP7	Scottish Planning Policy (SPP) 7: Planning and Flooding	Scottish Executive, 2004	2.7.1,
IET Guidance Note 1	Selection and Erection of Equipment, 6 <sup>th</sup> Edition	IET, 2011	3.13.3, 3.13.4
Technical Note TN137	Selection and Use of Fixings in Concrete and Masonry: Interim update to CIRIA Guide 4	CIRIA, 1991	4.2.40
	Specification for the reinstatement of openings in highways, 3 <sup>rd</sup> edition	HAUC, 2010	4.3.1, 4.3.5,
C521	Sustainable Urban Drainage Systems: Design Manual for Scotland and Northern Ireland	CIRIA, 2000	Appendix X
	Tables for the Hydraulic Design of Pipes, Sewers and Channels: 8 <sup>th</sup> edition. Volume 2	HR Wallingford, 2006	2.25.3
C697	The SUDS Manual (C697)	CIRIA, 2007	2.7, 2.8
Report R97	Trenching Practice, 2 <sup>nd</sup> edition	CIRIA, 1992	4.3.1
	Water Industry Mechanical Electrical Specification (WIMES) 4.01: Paints & Polymeric Coatings for Corrosion Protection	ESR Technology, 2005	2.26.4
	Water Industry Mechanical Electrical Specification (WIMES) 3.03: General Data Sheet	ESR Technology, 2011	3.5
	Winter Concreting	Concrete Information Ltd, 1985	4.4.5

Number	Title	Published by/ Date	Reference
PPG 5	Works or Maintenance in or near Water	Environment Agency/SEPA/Environment and Heritage Service Northern Ireland	4.3.2
PPG 6	Working at Construction and Demolition Sites	Environment Agency/SEPA/Environment and Heritage Service Northern Ireland	4.3.2

## B. SCOTTISH WATER'S STANDARDS AND SPECIFICATIONS

Number	Title	Owner
SSP-SP-DRA-07000750	Typical Manhole Details up to 6m Deep	Scottish Water
SSP-SP-DRA-07000751	Ridged Pipe Bedding Detail	Scottish Water
SSP-SP-GUI-09000900	MCC Standard Product Guidance	Scottish Water
SSP-SP-STA-09000001	Standard Product Motor Control Centre (MCC) Product Catalogue	Scottish Water
SSP-SP-STA-09000200	Waste Water Pumping Station Catalogue	Scottish Water
SSP-SP-STA-09000201	Waste Water Pumping Station Product Spec	Scottish Water
SSP-SP-SPE 05000501	General Requirements	Scottish Water
SSP-SP-SPE-05005017	Provision of Drawing 'CAD Drawing Frames'	Scottish Water
SSP-SP-ADO-05000502	Scottish Water Amendments "The Civil Engineering Specification for the Water Industry" (CESWI 7)	Scottish Water
SSP-SP-SPE-03000302	Waste Water Collection	Scottish Water

Copies of these documents and other associated Standard and Specification documents are available from Scottish Water.



# APPENDIX II – BRITISH STANDARDS INCLUDING EUROPEAN STANDARDS, CODES OF PRACTICE AND WATER INDUSTRY SPECIFICATIONS

## List of Standards and Water Industry Specifications/Information and Guidance Notes to which reference is made in this Specification

NOTE: Water Industry Specifications (WISs) have replaced specifications previously published as Information and Guidance Notes (IGNs) and adopt the same numbering system.

### Standard types:

BS	British Standard
BS EN	European Standard adopted as a British Standard
BS EN ISO	International Standard adopted as a British and European Standard
PD	Published Document
WIS	Water Industry Specification
IGN	Information and Guidance Note
PAS	Publically Available Specification

Type	Number	Title	Reference
BS	65	Specification for vitrified clay pipes, fittings and ducts, also flexible mechanical joints for use solely with surface water pipes and fittings	4.2.18
BS EN	124	Gully tops and manhole tops for vehicular and pedestrian areas. Design requirements, type testing, marking, quality control	Figure 14 - 15, 4.2.33
BS EN	197	Cement	4.4.9
	Part 1	Composition, specifications and conformity criteria for common cements	4.2.8
BS EN	206	Concrete. Specification, performance, production and conformity	4.2.9, 4.4.1, 4.4.2, 4.4.5
BS EN	295	Vitrified clay pipe systems for drains and sewers	4.2.18
	Part 1	Requirements for pipes, fittings and joints	4.2.18
	Part 4	Requirements for adaptors, connectors and flexible couplings	4.2.42
	Part 7	Requirements for pipes and joints for pipe jacking	4.2.18
BS EN	450	Fly ash for concrete	
	Part 1	Definition, specifications and conformity criteria	4.2.8
BS EN	459	Building lime	
	Part 1	Definitions, specifications and conformity criteria	4.2.10
BS	476	Fire tests on building materials and structures	
	Part 7	Method of test to determine the classification of the surface spread of flame of products	2.27.2
	Part 20	Method for determination of the fire resistance of	2.27.2

Type	Number	Title	Reference
		elements of construction (general principles)	
	Part 21	Methods for determination of the fire resistance of loadbearing elements of construction	2.27.2
	Part 22	Method for determination of the fire resistance of non-loadbearing elements of construction	2.27.2
	Part 23	Methods for determination of the contribution of components to the fire resistance of a structure	2.27.2
BS EN	598	Ductile iron pipes, fittings, accessories and their joints for sewerage applications. Requirements and test methods	4.2.20
BS EN	622	Fibreboards. Specifications	
	Part 1	General requirements	4.2.28
	Part 4	Requirements for softboards	4.2.28
BS EN	681	Elastomeric seals. Material requirements for pipe joint seals used in water and drainage applications	
	Part 1	Vulcanized rubber	4.2.25
BS EN	752	Drain and sewer systems outside buildings	2.18, 2.21, 4.2.35
BS EN	771	Specification for masonry units	
	Part 1	Clay masonry units	4.2.41
BS EN	772	Methods of test for masonry units	
	Part 2	Determination of percentage area of voids in masonry units (by paper indentation)	4.2.41
BS EN	805	Water supply. Requirements for systems and components outside buildings	4.7.9
BS EN	818	Short link chain for lifting purposes. Safety	
	Part 1	General conditions of acceptance	4.2.37
	Part 3	Medium tolerance chain for chain slings. Grade 4	4.2.37
BS EN	934	Admixtures for concrete, mortar and grout	
	Part 3	Admixtures for masonry mortar. Definitions, requirements, conformity and marking and labelling	4.2.12
BS EN	998	Specification for mortar for masonry	
	Part 1	Rendering and plastering mortar	4.2.12
	Part 2	Masonry mortar	4.2.12
BS	1052	Specification for mild steel wire for general engineering purposes	4.2.14
BS	1088	Marine plywood	
	Part 1	Requirements	2.82.2
BS EN	1092	Flanges and their joints. Circular flanges for pipes, valves, fittings and accessories, PN designated	3.15, 3.16
	Part 2	Cast iron flanges	3.3.6, 4.2.20, 4.2.36
BS EN	1097	Tests for mechanical and physical properties of aggregates	
	Part 6	Determination of particle density and water absorption	4.2.4

Type	Number	Title	Reference
BS EN	1127	Explosive atmospheres. Explosion prevention and protection	
	Part 1	Basic concepts and methodology	3.1
BS EN	1171	Industrial valves. Cast iron gate valves	3.15
BS EN	1295	Structural design of buried pipelines under various conditions of loading	
	Part 1	General requirements	4.2.21, 4.5.2, 4.5.4,
BS	1363	13 A plugs, socket-outlets, adaptors and connection units	2.27.3
BS EN	1401	Plastics piping systems for non-pressure underground drainage and sewerage. Unplasticized poly(vinyl chloride) (PVC-U)	
	Part 1	Specifications for pipes, fittings and the system	3.13.4, 4.2.21
BS EN ISO	1460	Metallic coatings. Hot dip galvanized coatings on ferrous materials. Gravimetric determination of the mass per unit area	4.2.39, 4.2.40
BS EN ISO	1461	Hot dip galvanized coatings on fabricated iron and steel articles. Specifications and test methods	Figure 8, 4.2.37, 4.2.38, 4.2.40
BS EN	1563	Founding. Spheroidal graphite cast iron	4.2.36
BS EN	1610	Construction and testing of drains and sewers	4.5.1, 4.7.4, 4.7.5, 4.7.7
BS EN	1852	Plastics piping systems for non-pressure underground drainage and sewerage. Polypropylene (PP)	
	Part 1	Specifications for pipes, fittings and the system	4.2.45
BS EN	1916	Concrete pipes and fittings, unreinforced, steel fibre and reinforced	4.2.8, 4.2.19
BS EN	1917	Concrete manholes and inspection chambers, unreinforced, steel fibre and reinforced	Figure 9, Figure 10, Figure 11, Figure 12, 2.26.4, 4.2.8, 4.2.30, 4.2.31
BS ISO	1940	Mechanical vibration. Balance quality requirements for rotors in a constant (rigid) state	
	Part 1	Specification and verification of balance tolerances	3.3.7
BS EN	1991	Actions on structures	
	Part 1-1	Densities, self-weight, imposed loads for buildings	4.2.38
	Part 1-7	General actions. Accidental actions	4.2.38
BS EN	1992	Design of concrete structures	
	Part 1-1	General rules and rules for building	2.26.4
	Part 3	Liquid retaining and containment structures	2.26.4
BS EN	1996	Design of masonry structures	
	Part 1-2	General rules. Structural fire design	4.6.1
	Part 2	Design considerations, selection of materials and execution of masonry	4.6.1
	Part 3	Simplified calculation methods for unreinforced masonry structures	4.6.1

Type	Number	Title	Reference
BS EN ISO	2081	Metallic and other inorganic coatings. Electroplated coatings of zinc with supplementary treatments on iron or steel	4.2.40
BS	2782	Methods of testing plastics. Glass reinforced plastics	
	Part 10	Measurement of hardness by means of a Barcol impressor	4.2.38, 4.2.39
BS	3416	Specification for bitumen-based coatings for cold application, suitable for use in contact with potable water	4.2.20
BS EN ISO	3506	Mechanical properties of corrosion-resistant stainless steel fasteners	
	Part 1	Bolts, screws and studs	4.2.36
	Part 2	Nuts	4.2.36
BS	3692	ISO metric precision hexagon bolts, screws and nuts. Specification.	4.2.36
BS	3892	Pulverized-fuel ash	
	Part 2	Specification for pulverized-fuel ash to be used as a Type I addition	4.2.7
	Part 3	Specification for pulverized-fuel ash for use in cementitious grouts	4.2.7
BS	4027	Specification for sulphate-resisting Portland cement	4.2.8
BS	4190	ISO metric black hexagon bolts, screws and nuts. Specification	4.2.36
BS	4320	Specification for metal washers for general engineering purposes. Metric series	4.2.36
BS	4449	Steel for the reinforcement of concrete. Weldable reinforcing steel. Bar, coil and decoiled product. Specification	4.2.13
BS	4482	Steel wire for the reinforcement of concrete products. Specification	4.2.13
BS	4483	Steel fabric for the reinforcement of concrete. Specification	4.2.13
BS	4660	Thermoplastics ancillary fittings of nominal sizes 110 and 160 for below ground gravity drainage and sewerage	3.13.4, 4.2.21
BS	4729	Clay and calcium silicate bricks of special shapes and sizes. Recommendations	4.2.41
BS	4800	Schedule of paint colours for building purposes	2.27.2
BS	4999	General Requirements for rotating electrical machines	
	Part 141	Specification for standard dimensions	3.5
	Part 145	Specification for winding terminations	3.5
BS	5080	Structural fixings in concrete and masonry	
	Part 1	Method of test for tensile loading	4.2.40
	Part 2	Method for determination of resistance to loading in shear	4.2.40
BS	5212	Cold applied joint sealant systems for concrete pavements	
	Part 1	Specification for joint sealants	4.2.43

Type	Number	Title	Reference
PAS	5308	Control and instrumentation cables	
	Part 2	Specification for PVC insulated cables	3.11.5.3, 3.13.3
BS	5911	Concrete pipes and ancillary concrete products	2.2.6.4, 4.2.8
	Part 1	Specification for unreinforced and reinforced concrete pipes (including jacking pipes) and fittings with flexible joints (complementary to BS EN 1916:2002)	4.2.19
	Part 3	Specification for unreinforced and reinforced concrete manholes and soakaways (complementary to BS EN 1917:2002)	Figure 9, Figure 10, Figure 11, Figure 12, 4.2.30, 4.2.31
	Part 4	Specification for unreinforced and reinforced concrete inspection chambers (complementary to BS EN 1917:2002)	2.26.4
BS	5955	Plastics pipework (thermoplastics materials)	
	Part 6	Code of practice for the installation of unplasticized PVC pipework for gravity drains and sewers	4.5.1
BS	5975	Code of practice for temporary works procedures and the permissible stress design of falsework	4.4.7
BS	6004	Electric cables, PVC insulated and PVC sheathed for voltages up to and including 300/500 V, for electric power and lighting	2.27.3, 3.13.3
BS	6031	Code of practice for earthworks	4.3.1
BS	6073	Precast concrete masonry units	
	Part 2	Guide for specifying precast concrete masonry units	4.2.41
BS	6076	Specification for polymeric film for use as a protective sleeving for buried iron pipes and fittings (for site and factory application)	4.2.17, 4.2.20
BS	6164	Code of practice for health and safety in tunnelling in the construction industry	4.3.1
BS	6180	Barriers in and about buildings. Code of Practice	4.2.40
BS	6213	Selection of construction sealants. Guide	4.2.43
BS	6231	Electric cables. Single core PVC insulated flexible cables of rated voltage 600/1000 V for switchgear and controlgear wiring	3.11.5.1, 3.13.3
BS	6346	Electric cables. PVC insulated, armoured cables for voltages of 600/1000 V and 1900/3300 V	3.13.3
BS	6398	Specification for bitumen damp-proof courses for masonry	4.2.28
PD	6678	Guide to the specification of masonry mortar	4.2.12
PD	6682	Aggregates	
	Part 1	Aggregates for concrete. Guidance on the use of BS EN 12620	4.2.4, 4.2.5, 4.2.6
	Part 3	Aggregates for mortar. Guidance on the use of BS EN 13139	4.2.6
BS	6744	Stainless steel bars for the reinforcement of and use in concrete. Requirements and test methods	4.2.13

Type	Number	Title	Reference
BS EN ISO	7010	Graphical symbols. Safety colours and safety signs. Registered safety signs	3.10.2.3
BS	7371	Coatings on metal fasteners	
	Part 12	Requirements for imperial fasteners	4.2.40
BS	7430	Code of practice for protective earthing of electrical installations	3.13.8.1, 3.13.8.2
BS	7542	Method of test for curing compounds for concrete	4.2.46
BS EN ISO	7599	Anodizing of aluminium and its alloys. General specifications for anodic oxidation coatings on aluminium	4.2.38
BS	7671	Requirements for electrical installations. IET Wiring Regulations. Seventeenth edition	1.2, 3.10.1, 3.10.2.3, 3.13.3, 3.13.4, 3.13.8.1
BS	7874	Method of test for microbiological deterioration of elastomeric seals for joints in pipework and pipelines	4.2.25
BS	7903	Guide to selection and use of gully tops and manhole covers for installation within the highway	Figure 9, Figure 10, Figure 11, Figure 12, 4.2.33
BS	7973	Spacers and chairs for steel reinforcement and their specification	
	Part 1	Product performance requirements	4.2.15
	Part 2	Fixing and application of spacers and chairs and tying of reinforcement	4.4.11
BS	8000-14	Workmanship on building sites. Code of practice for below ground drainage	4.5.1
BS ISO	8005	Carbonaceous materials used in the production of aluminium. Green and calcined coke. Determination of ash content	4.5.1
BS ISO	8179	Ductile iron pipes. External zinc-based coating	
	Part 1	Metallic zinc with finishing layer	4.2.20
BS	8204	Screeds, bases and in situ floorings	
	Part 2	Concrete wearing surfaces. Code of practice	4.4.3, 4.4.18
BS	8500	Concrete. Complementary British Standard to BS EN 206-1	2.26.4, 4.2.9, 4.4.1, 4.4.4, 4.4.5
	Part 1	Method of specifying and guidance for the specifier	2.26.4, 4.2.8, 4.4.11
	Part 2	Specification for constituent materials and concrete	4.2.4, 4.2.26, 4.4.2, 4.4.4
BS	8666	Scheduling, dimensioning, bending and cutting of steel reinforcement for concrete. Specification	4.4.10
BS	9295	Guide to the structural design of buried pipelines	4.5.2
BS EN ISO	9906	Rotodynamic pumps. Hydraulic performance acceptance tests. Grades 1, 2 and 3	3.4.1
BS EN	10025	Hot rolled products of structural steels	
	Part 2	Technical delivery conditions for non-alloy structural	4.2.38, 4.2.39

Type	Number	Title	Reference
		steels	
BS EN	10080	Steel for the reinforcement of concrete. Weldable reinforcing steel. General	4.2.13
BS EN	10088	Stainless steels	4.2.40
	Part 1	List of stainless steels	3.3.5, 3.3.13, 3.13.9.2
	Part 3	Technical delivery conditions for semi-finished products, bars, rods, wire, sections and bright products of corrosion resisting steels for general purposes	4.2.37, 4.2.38, 4.2.39
BS EN	10255	Non-alloy steel tubes suitable for welding and threading. Technical delivery conditions	4.2.38
BS EN	10296	Welded circular steel tubes for mechanical and general engineering purposes. Technical delivery conditions	
	Part 2	Stainless steel	4.2.38
BS EN ISO	11600	Building construction. Jointing products. Classification and requirements for sealants	4.2.43
BS	12056	Gravity drainage systems inside buildings	
	Part 2	Sanitary pipework, layout and calculation	2.21
BS EN	12201	Plastics piping systems for water supply, and for drainage and sewerage under pressure	
	Part 1	Polyethylene (PE). General	4.2.23
	Part 2	Polyethylene (PE). Pipes	4.2.23
	Part 3	Polyethylene (PE). Fittings	4.2.23
BS EN	12334	Industrial valves. Cast iron check valves	3.16
BS EN	12620	Aggregates for concrete	4.2.4, 4.2.5, 4.2.6
BS EN	13101	Steps for underground man entry chambers. Requirements, marking, testing and evaluation of conformity	Figure 9, Figure 10, Figure 11, Figure 12, 2.26.7.1, 4.2.34
BS EN	13139	Aggregates for mortar	4.2.6
BS EN	13463	Non-electrical equipment for use in potentially explosive atmospheres	3.1
BS EN	13476	Plastics piping systems for non-pressure underground drainage and sewerage. Structured-wall piping systems of unplasticized poly(vinyl chloride) (PVC-U), polypropylene (PP) and polyethylene (PE)	
	Part 1	General requirements and performance characteristics	4.2.22
	Part 2	Specifications for pipes and fittings with smooth internal and external surface and the system, Type A	4.2.22
	Part 3	Specifications for pipes and fittings with smooth internal and profiled external surface and the system, Type B	4.2.22
BS EN	13598	Plastics piping systems for non-pressure underground drainage and sewerage. Unplasticized poly(vinyl chloride) (PVC-U), polypropylene (PP) and polyethylene (PE)	

Type	Number	Title	Reference
	Part 1	Specifications for ancillary fittings including shallow inspection chambers	4.2.21, 4.2.32
	Part 2	Specifications for manholes and inspection chambers in traffic areas and deep underground installations	4.2.38, 4.2.39
BS EN	13602	Copper and copper alloys. Drawn, round copper wire for the manufacture of electrical conductors	3.13.3
BS EN	13670	Execution of concrete structures	4.4.6
BS EN	13706	Reinforced plastics composites. Specifications for pultruded profiles	
	Part 2	Method of test and general requirements	4.2.38, 4.2.39
	Part 3	Specific requirements	4.2.38, 4.2.39
BS EN ISO	14122	Safety of machinery. Permanent means of access to machinery	
	Part 3	Stairways, stepladders and guard-rails	4.2.38
	Part 4	Fixed ladders	4.2.39
BS EN	14188	Joint fillers and sealants	
	Part 1	Specifications for hot applied sealants	4.2.43
BS EN	14396	Fixed ladders for manholes	4.2.39
BS EN	14399	High-strength structural bolting assemblies for preloading	4.2.36
BS ISO	14654	Epoxy-coated steel for the reinforcement of concrete	4.2.13
BS EN	14680	Adhesives for non-pressure thermoplastic piping systems. Specifications	4.2.21
BS EN	14814	Adhesives for thermoplastic piping systems for fluids under pressure. Specifications	4.2.21
BS EN	15167	Ground granulated blast furnace slag for use in concrete, mortar and grout	
	Part 1	Definitions, specifications and conformity criteria	4.2.8
BS EN	50086	Specification for conduit systems for cable management	
	Part 1	General requirements	3.13.4
	Part 2	Particular requirements	3.13.4
BS EN	50288	Multi-element metallic cables used in analogue and digital communication and control	
	Part 7	Sectional specification for instrumentation and control cables	3.11.5.3, 3.13.3
BS EN	50525	Electric cables. Low voltage energy cables of rated voltages up to and including 450/750 (U0/U)	3.7, 3.11.5.1
BS EN IEC	60034	Rotating electrical machines	
	Part 1	Rating and performance	3.5, 3.6, 3.7
	Part 2-1	Standard methods for determining losses and efficiency from tests (excluding machines for traction vehicles)	3.5
	Part 2.2	Specific methods for determining separate losses of large machines from tests. Supplement to IEC 60034-2-2	

















Type	Number	Title	Reference
	Part 5	Degrees of protection provided by the integral design of rotating electrical machines (IP code). Classification	3.5
	Part 6	Methods of cooling (IC code)	3.5
	Part 7	Classification of types of constructions and mounting arrangements (IM code)	3.5
	Part 8	Terminal markings and direction of rotation	3.5
	Part 9	Noise limits	3.5
	Part 11	Thermal protection	3.5
	Part 14	Mechanical vibration of certain machines with shaft heights 56 mm and higher. Measurement, evaluation and limits of vibration severity	3.5
	Part 30	Efficiency classes of single-speed, three-phase, cage-induction motors (IE code)	3.5, 3.6
BS EN	60079	Explosive atmospheres	3.1, 3.8
	Part 1	Equipment protection by flameproof enclosures "d"	3.8
	Part 7	Equipment protection by increased safety "e"	3.8
	Part 10-1	Classification of areas. Explosive gas atmospheres	3.11.9.5
	Part 14	Electrical installations, design, selection and erection	3.8, 3.11.5.2
BS EN	60085	Electrical insulation. Thermal evaluation and designation	3.7
BS EN	60204	Safety of machinery. Electrical equipment of machines	3.5
	Part 1	General requirements	3.11.9.3, 3.12.4
BS EN	60309	Plugs, socket-outlets and couplers for industrial purposes	
	Part 2	Dimensional interchangeability requirements for pin and contact-tube accessories	3.11.7
BS EN	60423	Conduit systems for cable management. Outside diameters of conduits for electrical installations and threads for conduits and fittings	3.13.4
BS EN	60529	Degrees of protection provided by enclosures (IP code)	3.7, 3.13.5.1
BS EN	60669	Switches for household and similar fixed electrical installations	
	Part 1	General requirements	2.27.3
BS EN	60898	Electrical accessories. Circuit breakers for overcurrent protection for household and similar installations	3.11.9.2, 3.12.3
BS EN	60947	Low-voltage switchgear and controlgear	
	Part 1	General rules	3.11.1
	Part 2	Circuit breakers	3.11.1
	Part 3	Switches, disconnectors, switch-disconnectors and fuse-combination units	3.11.1
	Part 4	Contactors and motor-starters	3.11.1, 3.11.9.4, 3.12.5
	Part 5	Control circuit devices and switching elements	3.11.1
	Part 6	Multiple function equipment	3.11.1
	Part 7	Ancillary equipment	3.11.1
BS EN	61008	Residual current operated circuit-breakers without	3.11.9.2, 3.12.3

Type	Number	Title	Reference
		integral overcurrent protection for households and similar uses (RCCBs)	
BS EN	61009	Residual current operated circuit-breakers with integral overcurrent protection for households and similar uses (RCBOs)	3.11.9.2, 3.12.3
BS EN	61439	Low-voltage switchgear and controlgear assemblies	
	Part 1	General rules	3.11.3.1
	Part 2	Power switchgear and controlgear assemblies	3.11.2
	Part 3	Distribution boards intended to be operated by ordinary persons (DBO)	3.11.9.2, 3.12.3
BS EN	61558	Safety of transformers, reactors, power supply units and combination thereof	3.11.9.3, 3.12.4
BS EN	62444	Cable glands for electrical installations	3.13.5.1
IGN	4-01-03	Pressure testing of pressure pipes and fittings for use by public water suppliers	4.7.9, 4.7.10
IGN	4-08-01	Bedding and sidefill materials for buried pipelines	4.2.26, 4.5.2
IGN	4-08-01A	Bedding and sidefill materials for buried pipelines: Amendment No.1	4.2.26, 4.5.2
WIS	4-08-02	Specification for bedding and sidefill materials for buried pipelines	4.2.26
WIS	4-08-02A	Specification for bedding and sidefill materials for buried pipelines	4.2.26
IGN	4-11-01	Vitrified clay pipes and fittings	4.2.18
IGN	4-21-01	Ductile iron pipes and fittings	4.2.20
WIS	4-32-05	Specification for polyethylene (PE) pipes for sewer linings (non-pressure applications)	4.5.5
WIS	4-32-08	Specification for the fusion jointing of polyethylene pressure pipeline systems using PE80 and PE100 materials	4.5.5
IGN	4-32-18	The choice of pressure ratings for polyethylene pipe systems for water supply and sewerage duties	4.2.23
WIS	4-35-01	Specification for thermoplastics structured wall pipes – supplementary test requirements	4.2.22
WIS	4-41-01	Specification for flexible couplings for gravity sewerage and drainage pipes	4.2.42
IGN	4-51-01	External zinc coating of ductile iron pipe	4.2.20
WIS	4-52-01	Specification for polymeric anti-corrosion (barrier) coatings	4.2.20
WIS	4-52-01A	Specification for polymeric anti-corrosion (barrier) coatings: Amendment	4.2.20
IGN	4-52-02	The use of polymeric anti-corrosion (barrier) coatings	4.2.20
WIS	4-52-03	Specification for anti-corrosion coatings on threaded fasteners: Amendment	4.2.36
WIS	4-52-03A	Specification for anti-corrosion coatings on threaded fasteners: Amendment	4.2.36

Copies of the WIS and IGN documents can be obtained from [www.wis-ign.org](http://www.wis-ign.org).

# APPENDIX III – STANDARD SYMBOLS FOR USE ON DRAWINGS

FIGURE 29

150mm 1/83 	FW Sewer	FW Sewer	Pipe diameter and gradient
225mm 1/156 	SW Sewer		Pipe diameter and gradient
300mm 1/150 	Combined Sewer		Pipe diameter and gradient
 F1(22.23)	Adoptable Foul Manhole		Reference and invert level
 S1(23.67)	Adoptable Surface Water Manhole		Reference and invert level
 C1(21.56)	Adoptable Combined Manhole		Reference and invert level
(22.0)  F3(20.26)	Backdrop Manhole		Reference and invert levels
(19.65) 	Pumping Station with invert level of inlet		
100mm 	Rising Main - Foul		Diameter of pipe & direction of flow
150mm 	Rising Main - Surface Water		Diameter of pipe & direction of flow
150mm 	Rising Main - Combined		Diameter of pipe & direction of flow
	Air Release Valve		Use of colour
HB 	Hatch Box		
EM 	Emptying Valve		

If it is required to use colour to enhance the presentation of the drawings the following colours should be used:

Foul	- Brown
Surface Water	- Dark Blue
Combined	- Red
Water courses	- Light Blue
Building over/basements	- Orange
Property not connected	- Yellow

# APPENDIX IV – PARLIAMENTARY ACTS AND REGULATIONS (TO WHICH REFERENCE IS MADE IN OR ARE RELEVANT TO THIS SPECIFICATION)

Title	Reference
Administration of Justice (Scotland) Act 1972	Appendix V
Arbitration (Scotland) Act 2010	Appendix V
Building (Scotland) Regulations 2004	2.15
Companies Acts 2006	Appendix V
Construction (Design and Management) Regulations	1.3,2.9.9
Dangerous Substances and Explosive Atmospheres Regulations 2002 (DSEAR)	2.26.3, 3.10.2.3, Appendix VI
Electrical Equipment (Safety) Regulations 1994	3.13.5.3
Electricity Safety, Quality and Continuity Regulations 2002	3.13.8.1
Electricity Supply Regulations 1988	
Electromagnetic Compatibility (EMC) Directive 2004/108/EC	3.11.1, 3.11.4.2, 3.11.4.3
Electromagnetic Compatibility Regulations 2006	3.13.5.3
European Directive 94/9/EC (ATEX 95)	3.1
Equipment and Protective Systems Intended for Use in Potentially Explosive Atmospheres Regulations 1996	3.1
Equipment and Protective Systems Intended for Use in Potentially Explosive Atmospheres (Amendment) Regulations 2001	3.1
Flood Prevention (Scotland) Act 1961	Appendix VIII
Flood Prevention and Land Drainage (Scotland) Act 1997	Appendix VIII
Flood Risk Management (Scotland) Act 2009	2.7, Appendix VIII
Health and Safety at Work etc. Act 1974	2.3, 2.9.9,
Health and Safety (Safety Signs and Signals) Regulations 1996	3.10.2.3
Lifting Operations and Lifting Equipment Regulations 1998 (LOLER)	3.3.16.1
Local Government etc. (Scotland) Act 1994	
Low Voltage Directive 2006/95/EC	3.11.1
New Roads and Street Works Act 1991 (NRSWA)	2.18, 4.2.33, 4.3.5, 4.6.7, Appendix V, Glossary

Provision and Use of Work Equipment Regulations 1998 (PUWER)	3.3.16.1
Roads (Scotland) Act 1984	Appendix VIII
Sewerage (Scotland) Act 1968	1.2, 1.3, 2.1, 2.23, 2.3, Appendix V, AppendixVIII, Glossary
Confined Spaces Regulations 1997	
Provision of Water and Sewerage Services (Reasonable Cost) (Scotland) Regulations 2015	1.2, Glossary
Title Conditions (Scotland) Act 2003	Appendix V
Town and Country Planning (Scotland) Act 1997	1.2
Water Environment (Controlled Activities) (Scotland) Regulations 2011 as amended	1.3, 2.,2.7, Appendix XIII
Water Environment and Water Services (Scotland) Act 2003	
Water Industry (Scotland) Act 2002	Appendix V, Glossary

# APPENDIX V – MODEL FORMS OF AGREEMENT

- Style Section 21 “Build Over” Agreement: Minute of Agreement Incorporating Deed of Conditions
- Style Deed of Servitude
- Style Section 3A Authorisation, Letter, including Style Notice to be served by developers on Owners/Occupiers

## MINUTE OF AGREEMENT

between

**SCOTTISH WATER**, established under the Water Industry (Scotland) Act 2002 and having their principal office at Castle House, 6 Castle Drive, Carnegie Campus, Dunfermline, Fife KY11 8GG

and

[ ] who and whose successors as heritable proprietors of the land aftermentioned are referred to in this agreement as “the Developer”)

### RECITALS

- (a) the Developer is the heritable proprietor of [ ] being the subjects more particularly described in [ ]/ registered in the Land Register of Scotland under Title Number [ ] (“the Land”);
- (b) there is a sewer situated in the Land as shown coloured red on the Plan annexed hereto which sewer (“the Sewer”) is or will be vested in Scottish Water in terms of Section 16 of the Sewerage (Scotland) Act 1968;
- (c) in terms of Section 21 of the Sewerage (Scotland) Act 1968 no building shall be erected or embankment constructed over or in such a way as to interfere with or to obstruct access to the Sewer without the consent of Scottish Water;
- (d) the Developer has developed or is about to develop the Land in such a way that a building will be erected or embankment will be constructed (“the Structure”) over the Sewer or the Sewer will be interfered with or access to the Sewer will be obstructed;
- (e) the Developer has requested Scottish Water’s consent for the Structure; and
- (f) Scottish Water and the Developer have agreed to enter into this agreement to regulate their respective rights and obligations.

THEREFORE Scottish Water and the Developer HEREBY AGREE as follows:

1. Scottish Water consents to the erection or construction of the Structure, subject to the Developer meeting the conditions contained herein;
2. The developer accepts liability for any damage to the Sewer attributable to the Structure and all costs incurred in repairing the said damage;
3. The developer will free and relieve Scottish Water in all time coming in any liability for any loss, injury, damage, or additional costs in respect of the Sewer occurring either directly or indirectly as a result of the maintenance or presence of the Structure other than loss, injury, damage or additional costs arising due to the act or default of Scottish Water or those for whom it is responsible by law;
4. The developer will allow representatives of Scottish Water and/or its contractors access to the Land and the Structure at all reasonable times, on reasonable prior notice being given (except in the case of an emergency), for the purpose of inspection, maintenance, repair, clearance or renewal of the Sewer. The developer shall free and relieve Scottish Water for any damage to the Structure or loss arising from these operations. Scottish Water and its contractors will use due skill, care and diligence in

carrying out these operations;

5. The developer will, at its sole expense, at all times effect and maintain indemnity insurance to cover the occurrence of any damage to the Sewer arising from the existence of the Structure for such amount as from time to time in the reasonable opinion of Scottish Water represents an amount sufficient to cover all reasonably foreseeable costs, expenses, and claims. The developer will, on request, supply Scottish Water with particulars of such insurance and exhibit receipts for premiums;
6. All questions, differences or disputes which may arise between Scottish Water and the developer as to the true intent and meaning of this agreement or the implement thereof in any way will, failing agreement, be referred to an arbiter jointly appointed by the parties or failing agreement by an arbiter to be appointed at the request of either party by the Chairman for the time being of the Scottish Branch of the Royal Institution of Chartered Surveyors in respect of practical matters relating to the Development, or by the President of the Law Society of Scotland in respect of legal matters. The decision of such arbiter shall be binding upon the parties who shall each bear their own costs in respect of any such determination. The application of Section 3 of the Administration of Justice (Scotland) Act 1972 is expressly excluded.

*[Any number of other conditions specific to a particular agreement].*

7. The developer will be responsible for Scottish Water's reasonable legal fees in connection with the preparation of this agreement, together with the cost of any stamp duty or other duty payable thereon and the recording of this agreement in the Register of Sasines or Land Register and registration thereof in the Books of Council and Session and obtaining an extract or office copy thereof, as the case may be
8. The developer will grant to Scottish Water a Standard Security to be registered under the said title securing implementation of these presents.
9. On any transfer of the land the developer will require the disponee to novate these presents to Scottish Water and to grant a new Standard Security in favour of Scottish Water, whereupon the Standard Security by the developer will be discharged.
10. Scottish Water and the developer consent to the registration of these presents for preservation and execution as well as for publication:

IN WITNESS WHEREOF these presents consisting of this and the preceding three pages and the plan annexed are subscribed by [     ].

**PLEASE REMEMBER TO SIGN PLAN ALSO**



# DEED OF SERVITUDE

by

[ ] LIMITED

in favour of

[ ] LIMITED

with the consent of

[ ] LIMITED]

Property: [ ]

—

## DEED OF SERVITUDE by

[ ] **LIMITED**, incorporated under the Companies Acts (Registered Number[ ]) and having its Registered Office at [ ] (the "**Burdened Owner**")

in favour of

[ ] **LIMITED**, incorporated under the Companies Acts (Registered Number [ ]) and having its Registered Office at [ ] (the "**Benefited Owner**")

[with consent of

[ ] **LIMITED**, incorporated under the Companies Acts (Registered Number [ ]) and having its Registered Office at [ ] (the "**Consentor**")]

### 1. Definitions and Interpretation

#### 1.1 Definitions

In this Deed:-

"**Benefited Property**" means ALL and WHOLE [ ];

"**Burdened Property**" means ALL and WHOLE [ ];

"**Pipe**" includes any manholes, ventilating shafts, pumping stations, stormwater overflow pipes, outfall pipes or other accessories belonging to a pipe, unless the context otherwise requires;

"**Schedule**" means the schedule annexed to this Deed of Servitude;

"**Servitude Area**" means that area or strip of ground [X] metres in length and having an average width of [Y] metres, all as shown delineated [colour] and coloured [colour] on the plan annexed and signed as relative hereto and forming part of the Burdened Property;

"**Servitude Condition(s)**" means the conditions under which the Servitude Right(s) [is][are] to be exercised set out in Part 2 of the Schedule; and

"**Servitude Right(s)**" means the Servitude Right(s) set out in Part 1 of the Schedule.

#### 1.2 Interpretation

Save to the extent that the context or the express provisions of this Deed otherwise requires, in this Deed:-

1.2.1 words importing any gender include all other genders;

1.2.2 words importing the singular number only include the plural number and *vice versa*;

1.2.3 where at any one time there are two or more persons included in the expression "Benefited Owner" or "Burdened Owner" [or "Consentor"] obligations contained in this Deed which are expressed to be made by the party denoted by the expression in question are binding jointly and severally on them and their respective executors and representatives whomsoever, without the necessity of discussing them in their order;

1.2.4 words importing individuals include legal persons and *vice versa*;

- 1.2.5 references to this Deed or to any other document are to be construed as reference to this Deed or to that other document as modified, amended, varied, supplemented, assigned, novated or replaced from time to time;
- 1.2.6 any reference to a Clause, Schedule or Part of the Schedule is to the relevant Clause, Schedule or Part of the Schedule of or to this Deed;
- 1.2.7 any phrase introduced by the words "including", "include", "in particular" or any similar expression is to be construed as illustrative only and is not to be construed as limiting the generality of any preceding words; and
- 1.2.8 any rights reserved to the Benefited Owner are exercisable by the tenants, agents, employees, workmen and others authorised by them from time to time.

### **1.3 Headings**

The headings in this Deed are included for convenience only and are to be ignored in construing this Deed.

### **1.4 Schedule**

The Schedule forms part of this Deed.

## **2. Grant of Servitude**

[IN CONSIDERATION of the sum of [ ] £([ ]) STERLING paid to the Burdened Owner by the Benefited Owner,] the Burdened Owner [with the consent of the Consentor for its interest in the Burdened Property] grants the Servitude Right(s) but subject always to the Servitude Condition(s) (if any).

## **3. Date of Commencement of Servitude**

The Servitude Right(s) granted by this Deed will be exercisable with effect from [ ] notwithstanding the dates hereof.

## **4. Costs**

[The Benefited Owner will pay on demand the reasonable legal and surveyor's costs necessarily incurred by the Burdened Owner in connection with the negotiation and completion of this Deed, together with all disbursements incurred by the Burdened Owner and [all irrecoverable] Value Added Tax on such of the foregoing costs and other items as bear it. Such costs and others will include all (if any) stamp duty land tax payable.]

## **5. Consent to Scottish Water Taking Over the Pipe[s] in the Servitude Area**

The Burdened Owner consents to the vesting of the pipe[s] in the Servitude Area in Scottish Water, established under the Water Industry (Scotland) Act 2002 and having its principal office at Castle House, 6 Castle Drive, Carnegie Campus, Dunfermline, Fife, KY11 8GG, as [a] public sewer[s] under the relevant statutory powers and for the future operation and maintenance of [it][them] as part of the public sewerage system, all as subject to the statutory rights and duties of the said Scottish Water including unrestricted access to the Burdened Property for the purpose of laying, operating, inspecting, maintaining, repairing, cleansing, emptying, ventilating or renewing the outflow pipe and that once the said Scottish Water in its sole discretion is satisfied that the Pipe complies with the construction standards set out in the Edition of Sewers for Scotland as may be applicable at the time and any other conditions set by Scottish Water who has agreed to take over the said pipe[s] in accordance herewith.

**6. Arbitration**

Any dispute arising under this Deed of Servitude shall be determined, in default of agreement, by a single arbiter to be appointed by the parties hereto or, failing agreement, to be appointed on the application of any of the parties (after notice in writing to the other parties) by the Chairman of the Scottish Branch of the Royal Institution of Chartered Surveyors and the provisions of the Arbitration (Scotland) Act 2010 and any statutory modification or re-enactment thereof for the time being in force shall apply to any such reference or determination.

**7. Warrandice**

The Burdened Owner grants warrandice.

**8. No Applications**

No application may be made to the Lands Tribunal for Scotland under section 90(1)(a)(i) of the Title Conditions (Scotland) Act 2003 in respect of the Servitudes set out in this Deed for a period of five years after the [registration of this Deed in the Land Register of Scotland] [recording of this Deed in the General Register of Sasines]. IN WITNESS WHEREOF

This is the Schedule referred to in the foregoing Deed of Servitude by [ ] in favour of [ ] [with consent of [ ]]

**[NOTE: THE PROVISIONS OF PARTS 1 AND 2 OF THE SCHEDULE ARE MERELY SUGGESTED CLAUSES/WORDING AND ARE, IN SOME CASES, INCOMPLETE. DETAILED CONSIDERATION NEEDS TO BE GIVEN TO EACH CASE.]**

### **Part 1**

#### **The Servitude Right(s)**

The following Servitude Right(s) [is][are] imposed on the Burdened Property in favour of the Benefited Property:-

[A Servitude Right of access and egress at all times and for all purposes for pedestrians and vehicles (including heavy vehicles) over and across the Burdened Property.]

[A Servitude Right to lay a pipe not exceeding [ ] in width under the Servitude Area. ]

[A Servitude Right of access to the [Burdened Property] [Servitude Area] for the purpose of laying, inspecting, repairing, maintaining, renewing, replacing [ ] subject to giving to the owner for the time being of the Burdened Property at least [ ] days' written notice (except in emergency).]

[OR SPECIFY OTHER SERVITUDES IN QUESTION ]

## Part 2

### The Servitude Conditions

The Servitude Right(s) created by this Deed [is][are] subject to the following Servitude Conditions:-

1. [The owner for the time being of the Benefited Property will:-
  - 1.1 make good on demand all damage caused to the [Burdened Property] [Servitude Area] by reason of the exercise of the Servitude Right[s] by the owner for the time being of the Benefited Property or their tenants, agents, employees, workmen and others authorised by them from time to time, to the reasonable satisfaction of the owner for the time being of the Burdened Property;
  - 1.2 procure that the Servitude Right[s] [is][are] exercised so as to cause the minimum disturbance, nuisance or annoyance reasonably practicable to the owner for the time being of the Burdened Property and their tenants or occupiers, and all other adjoining or neighbouring proprietors, tenants or occupiers; and
  - 1.3 indemnify the owner for the time being of the Burdened Property in respect of all claims, demands, expenses, liabilities, actions or others arising in consequence of the exercise of the Servitude Rights by the owner for the time being of the Benefited Property.]

## STYLE SECTION 3A AUTHORISATION

Dear Sirs

### DRAFT PRO FORMA SECTION 3A AUTHORISATION

In terms of Section 3A(1) of the Sewerage (Scotland) Act 1968 (“the Act”) and on behalf of Scottish Water I hereby authorise [*insert name and address of developer*] (“the developer”) to construct a sewer along the line(s) coloured [*insert colour*] on the plan annexed and signed as relative hereto (“the Sewer”).

This authorisation is given strictly on the basis that the developer complies with the following conditions, namely:

1. The developer submits all plans in connection with the design and layout of the proposed works to Scottish Water, as required by Scottish Water, for written approval by Scottish Water prior to the commencement of work;
2. The developer submits any necessary planning application in respect of the proposed works and exhibits to Scottish Water any necessary planning approval prior to the commencement of works;
3. The developer pays to Scottish Water all costs incurred by Scottish Water during the course of construction or on the completion of the works, the nature and extent of inspection being a matter within the sole control of Scottish Water;
4. The developer complies with all relevant provisions of the Act including, without prejudice to the foregoing generality:
  - (a) giving notice as required by any rule of law, failing which reasonable notice, to the Roads Authority, person responsible for the maintenance of the road, or owners of the solum off the road as appropriate pursuant to Section 3(1) (a) of the Act and the New Roads and Street Works Act 1991;
  - (b) the due service of notice on all land owners and occupiers of the Land in which the Sewer is to be constructed, pursuant to Section 3A(1)(b) and Section 3(2) of the Act, in accordance with the Style Notice attached to this authorisation;
  - (c) the settlement by the developer of all compensation claims under Section 20 of the Act at the instance of any party affected by the works carried out under this authorisation or otherwise howsoever arising from implementation of the works. The developer will, on request, produce evidence of the settlement of any such claims;
  - (d) indemnification of Scottish Water by the developer against any claims against Scottish Water for damages or compensation, howsoever arising, in connection with the construction of the Sewer.
5. The developer is required to notify all land owners and occupiers affected by the proposed works of the name and address of the contractor who will carry these out prior to the commencement of any work within the land affected.
6. The developer may not grant consent to another party to erect a building or construct an embankment over, or in such a way as to interfere with or obstruct access to, the sewer, unless he has first obtained the consent of Scottish Water.
7. Unless otherwise agreed, the developer shall be responsible for all costs, fees and outlays associated with and arising directly or indirectly out of the works.
8. Notice is also hereby given on behalf of Scottish Water in terms of Section 3A(2) of the Act that the sewer will not vest in Scottish Water through the operation of Section

16(1)(c) of the Act, until the date stated in the Transfer Certificate.

The developer will accordingly remain responsible for the Sewer constructed by or on behalf of the developer until such time as the works have transferred to Scottish Water in terms hereof.

Yours Faithfully,

For and on behalf of [ ] of Scottish Water

SIGNED .....



## STYLE NOTICE TO BE SERVED BY DEVELOPERS ON OWNERS/OCCUPIERS

[Recorded Delivery]

### STATUTORY NOTICE

[Name of Developer]

### SEWERAGE (SCOTLAND) ACT 1968

[Name, Address]

WHEREAS under Section 3A(1) of the Sewerage (Scotland) Act 1968 (“the 1968 Act”) [Name of developer] has been authorised by the [ ] of Scottish Water to construct a sewer as described below, NOTICE IS HEREBY GIVEN by [Name of developer] (“the developer”) under Section 3(1)(a)(ii) of the 1968 Act that the developer intends to construct a sewer in under or on that part of [your land/the land occupied by you]\* shown on the plan, and described in the Schedule, both attached to and signed as relative to this Notice.

You have a right to object to the proposed works within two months after the date of service of this Notice. If you object, the developer shall not proceed to execute the works, but may refer the matter to the Sheriff, who may grant consent to the proposed works, either unconditionally or subject to such terms and conditions as he thinks just, or may withhold his consent. Any objections should be submitted in writing to [provide contact name and address].

Under Section 20 of the 1968 Act. you are entitled to compensation for any loss, injury or damage sustained by you by reason of the exercise by the developer of the authorisation under Section 3A of the 1968 Act. If you wish to claim compensation, your claim should be submitted to [provide details] within twenty four months of the claim arising

Copies of the text of Sections 3, 3A and 20 of the 1968 Act are attached for your reference.

Dated this [ ] day of [ ]

[Name, address and designation of signatory]

# APPENDIX VI – GUIDANCE FOR DEVELOPERS ON VESTING OF FIRST TIME DISCRETE SEWERAGE SYSTEMS

## 1.1 General

1. In most instances, new developments would be connected to existing Scottish Water sewer networks. Wastewater treatment enhancement to support connection of new or existing developments to existing sewer networks shall be undertaken by Scottish Water.

2. The developer shall be aware that where treatment capacity needs to be upgraded, this shall be agreed with SEPA, designed, planned and procured. Development phasing discussions may be required.

3. Development connections that require a licensed trade effluent discharge or a significant variation to existing trade effluent licence shall be made through a licensed retail service provider. Where existing wastewater treatment plant capacity or processes need to be upgraded to support a trade effluent connection agreement, specific developer capital funding arrangements for Part 4 upgrades shall be agreed. The upgrade work on existing wastewater treatment plants will be in accordance with Scottish Water's current specification and procurement arrangements. The upgrade costs are to be met (either fully or in part) by the developer.

4. In exceptional cases, where it is impracticable due to the extreme remoteness of a development from an existing Scottish Water sewerage network, a new discrete sewerage system which fully meets Scottish Water's specification requirements may be provided by a developer provided the developer can demonstrate the following:

- Land ownership or control;
- The development is supported by the local plan and/or has full planning permission;
- The time remaining on the current planning permission;
- That plans are in place to ensure all connected properties and associated networks are fully compliant with the specification in this document and are subject to a Vesting Agreement which includes the adoption of the Part 4 assets (including the justification for the need to deliver the development via a discrete sewerage arrangement);
- Reasonable proposals are agreed in terms of build rate and interim operation of the wastewater treatment plant. Note: It is anticipated that most of these systems shall be based on passive treatment arrangements (subject to agreement with Scottish Water and SEPA), (i.e., septic tank, septic tank/reed bed, septic tank /trickling filter/humus tank);
- The wastewater treatment facility shall serve multiple (two or more) customers.

5. In these circumstances, the developer shall seek written confirmation from Scottish Water that the proposed wastewater treatment facility is fully compliant with Scottish Water's requirements before a Vesting Agreement can be initiated. The cost of the new Part 4 wastewater treatment works provision shall be fully met by the developer unless a specific contribution is agreed by Scottish Water. This would be specifically in relation to the marginal cost of enhanced sewerage arrangements, such as provision of additional capacity to allow future connections in line with agreed Local Authority development plans for the area adjacent to the proposed development.

6. Where new or existing private wastewater treatment facilities are proposed for vesting, specific technical advice shall be sought to ensure the correct (sustainable) level of treatment is agreed with SEPA and provided in accordance with Scottish Water's process selection matrix and design.

## 1.2 Detailed Design Review

1. The following detailed design documents shall be submitted to Scottish Water. These will be forwarded to an appointed process design consultant for review:

- a) treatment works' layout drawings in plan and section, including hydraulic profile;
- b) process and any M & E equipment design details (including standby provision) to demonstrate they are in accordance with Scottish Water's Specification 301 – WASTEWATER TREATMENT WORKS (including associated Specifications Series 100, 201-204, 501, 504, 601-604 and related WIMES and Civil Engineering Specification for the Water Industry).
- c) hazardous area classification drawings, risk assessments and installation verification process (refer to Scottish Water Specification 204 and the Dangerous Substances and Explosive Atmospheres Regulations 2002 (DSEAR));
- d) mechanical plant installation drawings and lifting strategy;
- e) electrical plant and installation drawings;
- f) telemetry I/O lists, produced in association with one of Scottish Water's approved telemetry integrators;
- g) mechanical and electrical equipment lists with manufacturer's details (where practicable these shall be from a Scottish Water approved framework supplier or a specific documented waiver agreed for any deviations);
- h) a treatment works commissioning plan or where Scottish Water is requested to vest an existing private treatment works, a list of non-conformance issues shall be provided. This will be reviewed by the Scottish Water regional asset planner on a similar basis to the "CAPEX 3 Process" for new assets procured by Scottish Water in delivery of its capital works programme. The review will confirm and agree any remedial works required to bring an existing private treatment works or its connected network up to the standard required by Scottish Water's specifications current at the time of the Vesting Agreement.

2. A report shall be produced by Scottish Water's appointed consultant within 28 days of an acceptable design submission, as detailed above, incorporating a remedial action plan with list (if necessary). If revisions or additional information are required, the design shall be re-submitted, with the appropriate re-submission fee, to Scottish Water.

3. Technical approval of the entire development proposal (foul and surface water sewers, SUD systems, pumping stations and wastewater treatment works) shall only be provided once the process and M & E installation is considered acceptable by Scottish Water's appointed framework consultant. The treatment arrangements shall be capable of meeting the SEPA consent over the full phased period of the development. On larger developments with complex (non-passive) Part 4 treatment processes, a professional indemnity warranty on the developer's design will be required where requested by Scottish Water.

### **1.3 Operation and Maintenance (O&M) Manuals**

1. Once construction of the wastewater treatment works are complete (or in the case of an existing works any agreed remedial works have been completed), the developer shall submit the O&M manuals to Scottish Water together with all associated documentation in both a paper copy and electronic format. The format of the submission shall be as detailed in Series 503 of Scottish Water's standard specifications for review by the regional asset planner. If any revisions are required or information is missing, the manuals must be re-submitted with the appropriate re-submission fee to Scottish Water.

2. Once the O&M manuals are considered acceptable, then a Pre-commissioning pro-forma shall be issued to the developer. This shall be completed and returned to Scottish Water seven days prior to the date set for the site commissioning visit by Scottish Water's framework consultant.

### **1.4 Operational Certificate**

1. A Site inspection and commissioning visit shall be carried out prior to the first house discharging to the catchment. The developer shall have previously completed both dry and wet testing of the

Works in its completed state, including any remedial works where a private Works is being retrospectively vested at the request of the developer.

2. Seven days prior to the site visit, the developer shall return a duly completed pre-commissioning pro-forma directly to Scottish Water's appointed framework consultant. A site visit for inspection will be arranged.

3. Site commissioning will only take place when:

- a) the works is fully constructed and all mechanical and electrical plant has been installed and tested by the developer. Completed inspection and test documentation (including pumps, aeration system, instruments, screens, actuated valves, MCC panels, instruments, etc.) must be provided with the pre-commissioning pro-forma;
- b) all self-snagged items have been fully addressed;
- c) O&M manuals have been submitted, revised (if required) and approved;
- d) details of the proposed competent contractor to carry out the operation and maintenance of the Works prior to the issue of a Vesting Certificate have been submitted to Scottish Water and approved. Scottish Water shall not take over operation of the Works until all the requirements of the Vesting Certificate have also been satisfied;
- e) the telemetry has been installed and tested.

4. The purpose of testing the telemetry at this time is to confirm that the installation can communicate with Scottish Water's Operations & Maintenance Centre (OMC). Telemetry shall only be "made live" on issue of the Vesting Certificate which triggers the start of Scottish Water's operation of the sewerage network and treatment works, together with the commencement of the 24-month Guarantee Period.

5. Keys for access to buildings, control panels, kiosks and covers shall be made available during the site visit. Appropriate facilities and personnel shall also be available to enable pumps and other similar removable submerged equipment to be lifted out for inspection. This will require suitably-qualified personnel to support the demonstration of equipment removal for its inspection during the site visit by Scottish Water's operational and asset management staff.

6. Commissioning shall be carried out in accordance with the agreed commissioning plan and will include:

- a) electrical plant installation;
- b) mechanical plant installation (including witnessing submerged removable equipment to be lifted using the certified installed facilities);
- c) the Works compliance with SEPA consent will be verified by means of a 28-day test based on random daily snap samples of final effluent. Compliance against non-sanitary consent conditions shall also be verified;
- d) pump performance shall be determined by drop test; mechanical screens operation based on level and timer control (manual screenings removal shall be demonstrated); grit removal arrangements demonstrated; settlement scrapers operation shall be visually inspected; aeration patterns and mixing checked; aeration DO control confirmed; trickling filter distribution and wetting rates checked; sludge removal from the treatment process witnessed, etc., as appropriate for the Works and confirmed in the approved pre-commissioning pro-forma.

7. If any part of the Works installation does not meet the relevant Scottish Water specification standards (allowing for any approved specification waivers), an Operational Certificate will not be issued. A report shall be produced by Scottish Water's framework consultant incorporating any remedial action list. The developer shall complete all actions and undertake any required re-commissioning of the Works or part thereof. The developer shall submit another pre-commissioning pro-forma, with confirmation that all snagging items have been addressed along with the appropriate re-visit fee, before a further site visit will be arranged. Where only minor snags have been identified these will be notified to the developer as requiring to be addressed prior to vesting.

8. On successful completion of the above, Scottish Water's framework consultant shall confirm in writing that the treatment process and associated civil works together with mechanical and electrical plant installation is of a standard suitable for vesting in Scottish Water. Scottish Water will then issue an Operational Certificate.

9. The Works will then be operated and maintained at the developer's expense, by an approved operation and maintenance contractor (or Scottish Water subject to the developer's agreement to cover any related operating costs incurred by Scottish Water prior to vesting). This provision recognises the issues where temporary supplementary dosing such as molasses or flushing, etc., is required until the development is substantially complete and a Vesting Certificate can be issued. The operation and maintenance regime adopted by the contractor will be approved by Scottish Water and can be subject to revisions at any time, in line with its internal task schedule and maintenance strategy for similar works. The contractor shall submit monthly reports to Scottish Water providing details of the condition of the Works, M & E plant breakdowns, final effluent sampling/analysis and other data normally captured in accordance with operational task schedules agreed with the developer for similar works. Failure to submit reports may delay the vesting process.

### **1.5 Vesting Certificate (Part 4 Assets)**

1. Once the development's Part 3 & 4 foul sewer infrastructure, including pumping stations and wastewater treatment works have been constructed, inspected and tested, the developer can apply for a Vesting Certificate.

2. The Reasonable Cost Contribution will not be released, in line with Scottish Water's customer scheme of charges. This is linked to property completions and connections within the development to the network assets covered by the Vesting Agreement.

3. In the case of a wastewater treatment works (Part 4 Asset), depending on the type of works provided, the developer may not be able to apply for a Vesting Certificate until it is confirmed by Scottish Water that there is sufficient biological loading on the Works to sustain the final treatment process.

4. The information which shall be submitted for review includes, but is not limited to, the following:

- a) CCTV survey of all foul sewers (showing no defects);
- b) manhole survey data;
- c) records of pipe tests carried out prior to and after backfilling;
- d) 'as-built record drawings;
- e) Health & Safety File;
- f) training documentation;
- g) Information to initiate the legal process of transferring land titles (this includes SPS sites, SUDs, (ponds/basins), and wastewater treatment plant and associated access arrangements), CAR licence and other statutory licences, notices and consents on any assets which Scottish Water have agreed in writing to vest.

5. The reports submitted by the developer's operating and maintenance contractor will be reviewed, and audited against Scottish Water telemetry records, to ensure the Works has been running without faults. If concerns are identified, then the issue of the Vesting Certificate will be delayed until the problems are resolved by the developer to the satisfaction of Scottish Water.

6. Scottish Water's appointed framework consultant will be instructed to visit the site and inspect M & E equipment and reconfirm the operation of the telemetry. Any items which have not been maintained or have identified performance issues, will be included in a snagging list. Subsequent visits by the appointed framework consultant to check snagging items have been addressed will be subject to a re-visit fee. If any problems identified are not resolved by the developer within three months of being identified, then Scottish Water may rectify them and charge the developer costs plus a fee.

7. Once all documentation has been approved, all snagging items have been satisfactorily addressed by the developer and, where necessary, Scottish Water operatives have been given training, a Vesting Certificate will be issued. This signifies the start of the Guarantee Period which will be two years.

8. During the Guarantee Period, Scottish Water is responsible for operating the assets.

9. Any equipment which requires replacement or renewal during this period will be re-charged to the developer or rectified by the developer within a timescale agreed with Scottish Water.

10. At the start of this period, the CAR licences shall be varied to make Scottish Water the named discharger. Prior to vesting, the legal process of transferring land title will be initiated, with all associated costs borne by the developer. All relevant documentation shall be in place to enable the transfer to occur on the date of vesting.

11. The formal vesting will initiate:

- a) power supply to transfer to Scottish Water's portfolio (A1 form);
- b) telecommunications site billing transfer to Scottish Water;
- c) confirmation that conveyance of the title to Scottish Water is executed on the date of vesting.

12. Once the above information is submitted to Scottish Water, and provided there are no outstanding issues relating to the operation of the Works and there are no outstanding bills, then the date for vesting of the Works and associated network will be confirmed.

# APPENDIX VII – DETERMINATION OF GREENFIELD RUNOFF PEAK FLOWS

The following example is an illustration of the calculation method for finding the stormwater runoff peak flows from a greenfield site.

## *Catchment Characteristics*

Site Area = 70 ha

SAAR = 750 mm

WRAP= 3

SOIL = 0.37

The formula, from Institute of Hydrology Report No. 124, is:

$$QBAR_{rural} = 0.00108AREA^{0.89}SAAR^{1.17}SOIL^{2.17}$$

The site is greater than 50 ha, therefore, apply the formula for the actual site area.

$$QBAR_{rural} = 0.00108 \times 0.7^{0.89} \times 750^{1.17} \times 0.37^{2.17}$$

$$QBAR_{rural} = 0.00108 \times 0.728 \times 2311 \times 0.116$$

$$QBAR_{rural} = 211 \text{ l/s}$$

Therefore,  $QBAR_{rural}/ha$  is 3.0 l/s/ha.

To get the 1-, 30- and 100-year throttle rates, the hydrological growth curves 1 or 2 are applicable for Scotland. For Curve 2:

1-year factor = 0.85

30-year factor = 1.90

100-year factor = 2.60

Therefore, greenfield limiting discharge rates are:

1-year throttle = 2.55 l/s/ha and 178 l/s for the site;

30-year throttle = 5.70 l/s/ha and 401 l/s for the site;

100-year throttle = 7.80 l/s/ha and 546 l/s for the site.

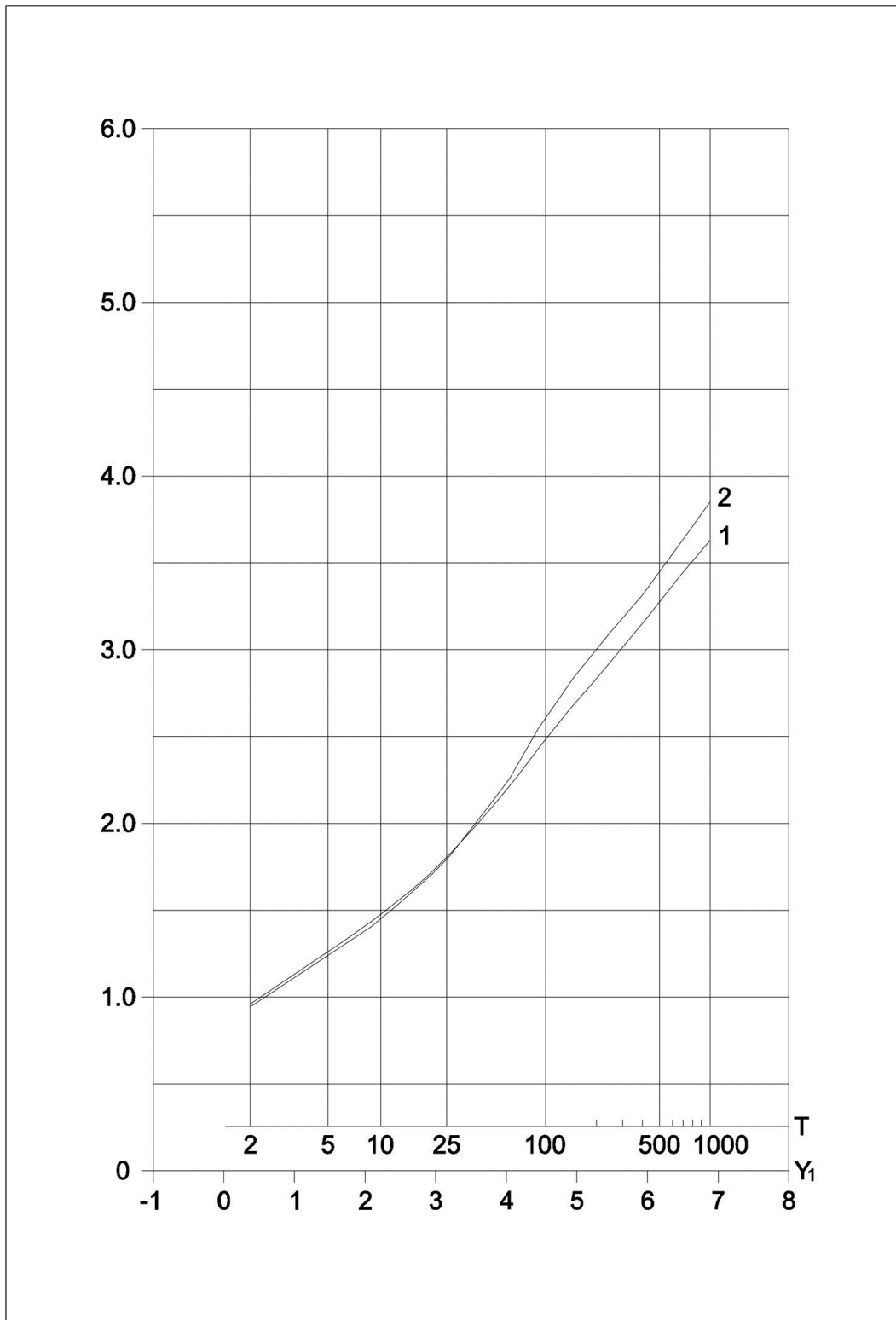
**FIGURE 30**

**HYDROLOGICAL GROWTH CURVE REGIONS – SCOTLAND**





**FIGURE 31**  
**HYDROLOGICAL GROWTH CURVES - SCOTLAND**



# APPENDIX VIII - RESPONSIBILITIES FOR MANAGING FLOOD RISK IN SCOTLAND

## 1.1 Introduction

In Scotland the primary responsibility for protecting land from flooding lies with the owner of the land concerned.

In 2009, the Flood Risk Management (Scotland) Act (FRM Act) was enacted by the Scottish Government. The Act replaces and amends previously existing legislation and sets a new plan-led approach for sustainable management of flood risk in Scotland. It also widens the roles and responsibilities of the organisations involved in flood risk management.

The Act creates a more joined up and coordinated process to manage flood risk at a national and local level.

Specific measures within the FRM Act include:

- A framework for coordination and cooperation between all organisations involved in flood risk management;
- Assessment of flood risk and preparation of flood risk management plans;
- New responsibilities for SEPA, Scottish Water and Local Authorities in relation to flood risk management;
- A revised, streamlined process for flood protection schemes;
- New methods to enable stakeholders and the public to contribute to managing flood risk; and
- A single enforcement authority for safe operation of Scotland's reservoirs.

The FRM Act makes provision for the Flood Prevention (Scotland) Act 1961 and Flood Prevention and Land Drainage (Scotland) Act 1961 to be repealed.

## 1.2 Planning

Scottish Planning Policy (Scottish Government 2014) sets out the national planning policy regarding development proposals and paragraphs 254 – 268 set out the policy principles for managing flood risk and drainage. SPP has the key aim of not just avoiding an increase in flood risk through locating development away from medium to high risk areas, but also reducing the vulnerability of existing and future development from all sources of flooding including fluvial, coastal and surface water. The SPP is supported by Planning Advice Note PAN 69: Planning and Building Standards Advice on Flooding, Scottish Executive, 2004, which provides detailed information, advice and case studies. The SPP and PAN encourage Local Authorities and Developers to consider flood risk early in the process. Plans to produce a consolidated PAN (bringing together PANs 61, 69 and 79) is now to be replaced by new, concise on-line flood risk guidance which should be available in summer 2015. Planning Authorities have powers provided under the Town and Country Planning (Scotland) Act 1997 to take flood risk into account in determining planning applications. If a proposal is likely to increase the number of buildings at risk of flooding, secondary legislation requires the authority to consult SEPA who have a statutory duty to provide advice. If a Planning Authority wishes to approve an application contrary to SEPA's advice, the application has to be notified to the Scottish Government who may decide to call it in for their own decision.

### 1.3 Scottish Government

The Scottish Government has overall responsibility for policy on flood management in Scotland. Under the FRM Act, the Scottish Ministers will approve the Flood Risk Management Strategies that will be produced by SEPA and will provide resources for these to be delivered through the existing funding mechanisms.

The Scottish Government is also responsible for setting out guidance to SEPA, Local Authorities and Scottish Water on fulfilment under the FRM Act, and in particular, on steps that should be taken to manage flooding in a sustainable manner.

Under the Roads (Scotland) Act 1984, the Scottish Government is responsible for carrying out works to keep trunk roads free from surface water.

### 1.4 SEPA

SEPA is the flood warning authority in Scotland and also has a strategic role in managing flood risk. SEPA's flood risk management responsibilities include:

- Working with the Scottish Government to implement the FRM Act;
- Coordinating and facilitating the development of plans to manage the risk of flooding in Scotland;
- Encouraging and facilitating the public and interested organisations to be part of the process;
- Ensuring that sustainable measures are taken and choosing which measures should be prioritised;

In addition, SEPA is the flood risk authority in Scotland with respect to land-use planning advice as a statutory consultee to this process and is also the flood mapping authority in Scotland, providing strategic level flood hazard and risk maps, on all sources of flooding, which support a number of elements of flood risk management in Scotland

(<http://www.sepa.org.uk/environment/water/flooding/flood-maps/>).

### 1.5 Local Authorities

Under the FRM Act, the Local Authorities are designated as Responsible Authorities and as such they have a duty to prepare and implement Local Flood Risk Management Plans jointly with the other Responsible Authorities by 2016. These will set out the measures which shall be carried out in order to manage flood risk in Scotland. Local Authorities are also responsible for assisting and contributing to SEPA's production of the National Flood Risk Assessment, Flood Risk and Hazard Maps and Flood Risk Management Strategies and Local Flood Risk Management Plans (to be completed by December 2015 and June 2016 respectively).

Local Authorities have powers to promote new flood alleviation schemes where these can be justified and funding is available. New and existing schemes will be included in the Local Flood Risk Management Plans and delivered accordingly.

Local Authorities remain responsible for managing flood risk in their area through activities such as maintaining road gullies, carrying out clearance and repair works and working with emergency services in response to severe flooding.

Under the FRM Act, Local Authorities are responsible for producing surface water management plans aimed at managing overland flooding, caused by the build-up of water on land following heavy rainfall or by a high water table causing ponding of standing water in low lying areas. The plans will then be implemented by the Responsible Authorities, as appropriate.

### 1.6 Scottish Water

Under the Sewerage (Scotland) Act 1968, Scottish Water has a duty to provide public drainage and is responsible for the drainage of rainwater runoff (surface water) from roofs and any paved ground surface within the property boundary for normal rainfall events.

Private pipework or guttering within the property boundary remains the responsibility of the homeowner. Scottish Water is also responsible for effectually draining its area of domestic sewage and trade effluent.

Additionally, Scottish Water helps to protect homes from flooding caused by sewers either overflowing or becoming blocked.

As a Responsible Authority under the FRM Act, Scottish Water has a duty to exercise its functions to reduce overall flood risk. Scottish Water also has a specific duty to assess flood risk from the sewerage system as well as to assist Local Authorities and SEPA in the production of the national flood risk assessment, plans and maps.

Scottish Water records flooding information in each of its operational areas into a Scottish Water Flooding Register. This records instances of flooding due to hydraulic overloading of the sewerage system. Measures stemming from this register along with those identified through the implementation of the FRM Act will be delivered through Scottish Water's quality and standards capital investment programme to reduce the risk of flooding in Scotland.

# APPENDIX IX – DSEAR PRELIMINARY ASSESSMENT RECORD

The answers to the following questionnaire and details of the person completing the form shall be recorded and included in the Health and Safety File:-

	Question	Answer (Yes/No)
1	Does the pumping station have any industrial effluents in the catchment? (if No, go to Question 2)	
1a	Are any of the industrial effluents considered hazardous with respect to DSEAR? (if No, go to Question 2)	
2	Is the pumping station located in an area with known presence of methane, either from geological or landfill sources?	
3	Are there any major road drainage connections within the pumping station catchment? (if No, pumping station is low risk)	
3a	If Yes to Question 3, are there more than two petrol stations within the pumping station catchment?	

**Note: - If you have answered “YES” to questions 1a, 2 or 3a above, the Generic DSEAR Risk Assessment does not apply and a full site-specific DSEAR risk assessment shall be required.**

Details of asset being assessed: -

Asset Name:	
Asset Address:	
Scottish Water Plant Number:	
Grid Reference (accurate to 1 m):	

Details of person carrying out assessment:

Name:	
Designation:	
Company:	
Company Address:	
Signature:	

# APPENDIX X - GLOSSARY OF TERMS AND ABBREVIATIONS

**Access point** – this is the provision to access a sewer or drain for maintenance or inspection and includes any manhole, inspection chamber or rodding eye.

**Active public open space** – an area of land open to use by the public that has specific provision for particular public use such as children’s play areas or pitches for football and cricket.

**Adoption** – this is the process whereby sewers are vested in Scottish Water and subsequently maintained at their expense **OR** once assets, e.g., sewers are constructed, and if Scottish Water has made an offer to adopt the asset, then the responsibility for ownership, operation and maintenance of the assets is transferred to Scottish Water.

**Application to Connect** – formal application for connection to public sewerage, using the appropriate Scottish Water application form available at [www.scottishwater.co.uk](http://www.scottishwater.co.uk). This shall be supported by appropriate design calculations for a sewerage system intended for vesting in Scottish Water, for Scottish Water’s audit.

**Aquatic bench** – aquatic benches are those shallow areas around the edge of a permanent pool surface water management facility that support aquatic vegetation, both submerged and emergent.

**Attenuation** – reduction of the peak rate of flow by providing storage to allow a volume of flow to discharge over a longer duration.

**Attenuation storage** – storage provided to enable the peak rate of flow of runoff to the receiving watercourse to be reduced.

**Basin** – see **Detention basin**.

**Blue roof** – a roof design that is intended to store water, typically rainfall. The storage surface provides a degree of retention and attenuation. Blue roofs can include open water surfaces, storage within or beneath a porous media or modular surface, or below a raised decking surface or cover.

**Brownfield site** – previously-developed land which is or was occupied by a permanent structure, including the curtilage of the developed land and any associated fixed surface infrastructure.

**Build-over agreement** – agreement to carry out any building work over the top of or within 3 metres of a public sewer to ensure that no damage is caused to it or restrictions made to the way it is operated and maintained.

**CCTV** – closed-circuit television.

**Completion Certificate** – certificate issued by Scottish Water to a developer, following an application, for sewers and surface water drainage including SUD systems and pumping stations, following completion of construction, inspection and testing to the requirements of ‘Sewers for Scotland 3<sup>rd</sup> Edition’.

**Curtilage** – the curtilage is the area of land around a building or group of buildings which is for the private use of the occupants of the buildings. For this purpose typically:

a) detached, semi-detached and terraced houses are each considered as a separate curtilage;

b) where a building contains a number of flats, the whole block of flats are considered as one curtilage;

c) separate commercial properties sited on land privately owned by a single body (e.g., a shopping centre, airport terminal, retail park, etc.) will be considered as a single curtilage if the commercial properties share the site access and facilities.

**Customer** – an individual or company involved with the development of housing and/or industrial/commercial development.

**DA** – drainage assessment.

**Guarantee Period** – the period during which the developer remains liable for correcting any defects that appear in the Works.

**Demarcation chamber** – this is an inspection chamber placed near the boundary of the property on the lateral drain.

**Detention basin** – a vegetated depression that is normally dry except following storm events, constructed to store surface water temporarily in order to attenuate flows. It may allow suspended solids to settle out or infiltration of surface water into the ground.

**Detention pond** – a pond designed to attenuate surface water runoff that has a permanent pool volume which is equal to or greater than one times the treatment volume.

**Developer** – an individual or company involved with the development of housing and/or industrial/commercial development.

**Development** – a development is the alteration or construction of new premises or properties requiring provision of new water and wastewater services.

**Diffuse pollution** – pollution arising from urban or rural land use activities (including agriculture) that is dispersed across a catchment or sub-catchment, and does not arise from an obvious discrete source.

**Drain** – this is a pipeline, usually underground, designed to carry foul sewage or surface water from buildings and paved areas associated with buildings within the same curtilage.

**Drainage assessment (DA)** – an assessment of the impact of the drainage of a site. This is normally required to support a planning application.

**Drainage system** – a single unit or collection of drainage units including pipes, SUD system elements and drainage products, used to convey or store surface water runoff and foul flows.

**Emergency overflow structure** – a purposely-designed structure to allow a controlled overflow which will not cause damage from a detention basin or pond in the event of the design standard being exceeded. Unless specified by Scottish Water, emergency overflows are not required for foul pumping stations.

**Flood frequency** – the probability of a location being flooded in any year. For example, where the flood frequency is 1%, flooding will be expected to occur on average once every 100 years in the long term.

**Footpath** – a road not associated with a carriageway for use by pedestrians only. (Note: The term pavement has another meaning and shall not be used to mean footpath).

**Footway** – that part of a road associated with a carriageway reserved exclusively for pedestrians. (Note: The term pavement has another meaning and shall not be used to mean footway).

**Green roof** – a roof with plants growing on its surface, which contributes to local biodiversity. The vegetated surface provides a degree of retention, attenuation and treatment of rainwater, and promotes evapotranspiration.

**Groundwater** – water that has percolated into the ground, including water in both the unsaturated zone and the water table.

**Impermeable surface** – a surface that does not permit the infiltration of water and, therefore, generates surface water runoff during periods of rainfall.

**Licensed provider** – a retailer which has received licences from the Water Industry Commission for Scotland to provide water and/or sewerage services to non-household users.

**Long-term storage** – the temporary retention of a proportion of surface water runoff which is disposed of by using infiltration or slow release (typically less than 2 litres per second per hectare) to the receiving water. Long-term storage is provided for the temporary flood storage of rare storm events and is normally separated from the attenuation storage.

**Manhole** – a chamber on a drain or sewer that provides access for personnel.

**Management train** – the management of surface water using an appropriate selection of drainage systems to hydraulically control and treat surface water runoff to provide an acceptable level of service and minimise the impact on the environment.

**Mechanical and electrical site inspection and commissioning visit** – inspection and commissioning visit by Scottish Water (or its appointed consultant) to a new pumping station that is to be vested that shall be carried out prior to the first house discharging into the pumping station catchment.

**NRSWA** – New Roads and Street Works Act 1991.

**Operational Certificate** – certificate issued by Scottish Water to a developer following an inspection of a pumping station by Scottish Water and its M & E consultant to assess compliance with the requirements of Sewers for Scotland, 3<sup>rd</sup> Edition. The inspection shall be carried out before the first house starts to discharge to the station.

**Operational code** – legally-binding document setting out operational coordination arrangements between Scottish Water and Licensed Providers in connection with the provision of water and sewerage services.

**Passive public open space** – an area of land open to use by the public that specifically has no particular public use (see also Active public open space).

**Pavement** – technical name for the road or car park surface and underlying structure, usually asphalt, concrete or block paving. Note: This term shall not be used to mean a footway or footpath.

**Percentage runoff** – the proportion of the amount of rainfall that is converted to runoff (see also Runoff coefficient).

**Permeable surface** – a surface that is formed of material that is itself impervious to water but allows infiltration of water to the underlying layers through the pattern of voids in the surface, e.g., concrete block paving.



**Permit to Connect** – when Scottish Water is satisfied with a developer's proposals to connect to its existing wastewater infrastructure, Scottish Water will issue a Permit to Connect. The permit applies solely to sewer connections and is not relevant to water connections or new site infrastructure.

**Public sewer** – a sewer that is vested in and maintained by Scottish Water.

**Pumping main** – this is a sewer through which foul sewage and/or surface water is pumped.

**Pumping station** – a below-ground structure designed to transfer foul flows (via pumps) from low level sewers to a higher level sewer. The pumping station includes (as a minimum) a wet well, valve chamber and above-ground kiosk.

**Rainwater harvesting system** – a system that collects rainwater from where it falls rather than allowing it to drain away. It includes water that is collected within the boundaries of a property, from roofs and surrounding surfaces.

**Reasonable cost contribution** – financial contribution paid by Scottish Water to a developer for new infrastructure for eligible sites. The Provision of Water and Sewerage Services (Reasonable Cost) (Scotland) Regulations 2015 set out the responsibilities of Scottish Water and developers, and the contributions that Scottish Water is required to provide to developers.

**Return period** – the average frequency of a specified condition. An "n"-year event is one that occurs on average over the long-term, once every "n" years.

**Scottish Water** – water and sewerage undertaker in Scotland established by the Water Industry (Scotland) Act 2002. Scottish Water is the sole undertaker for the provision of the public water and wastewater services in Scotland.

**SEPA** – Scottish Environment Protection Agency.

**Separate sewer** – a sewer used to convey either surface water or foul sewage but not a combination of both.

**Sewage/wastewater** – as defined by the Sewerage (Scotland) Act 1968. It includes all foul flows from a property and all surface water that falls on roof areas and hardstanding within the curtilage of a property, and is also commonly referred to as wastewater.

**Sewer** – pipe of generally greater than 150 mm in diameter for the transportation of wastewater from more than one property.

**Sewer connection** – generally a pipe that drains a single property. A sewer connection or drain generally remains private up to the boundary or curtilage of that private property or to the point it joins up with the drain from another property. At this point it becomes Scottish Water's responsibility. In flatted developments it can service more than a single property without being defined as a sewer.

**Sewerage/wastewater infrastructure** – all pipes, SUD systems, pumping stations and treatment works and similar infrastructure for the collection, transportation, treatment and disposal of sewage (wastewater).

**Soakaway** – a subsurface structure into which surface water is conveyed to allow infiltration into the ground.

**Source control** – the management of runoff at or near its source.

**Statutory surface water** – surface water that comes from roofs and paved surfaces within the curtilage of premises.

**SUD systems** – a sustainable urban drainage system which:

a) facilitates attenuation, settlement or treatment of surface water from two or more premises (whether or not together with road water); and

b) includes one or more of the following: inlet structures, swales, constructed wetlands, ponds, filter trenches, attenuation tanks and detention basins (together with any other associated pipes and equipment).

**Surface water** – water resulting from runoff of rain, melted snow or hail.

**Swale** – a shallow vegetated channel designed to conduct and retain water but may also permit infiltration. The vegetation filters particulate matter.

**Technical approval** – technical approval by Scottish Water of the entire development proposals (foul and surface water sewers, SUD systems and pumping stations).

**Transfer Certificate** – certificate issued to the developer on the agreed vesting date confirming the sewerage infrastructure is vested with Scottish Water.

**Treatment** – improving the quality of water by physical, chemical and/or biological means.

**Treatment train** – the application of a selection of drainage systems which provides treatment of the surface runoff such that the pollution impact on the receiving waters is minimised.

**Treatment volume ( $V_t$ )** – a calculated volume of water, usually referring to the permanent pool volume in a pond, which provides partial treatment to surface runoff. It is normally calculated on the site impermeable area and the local hydrological characteristics (see CIRIA Report C521).

**Underground storage** – a pre-fabricated, underground attenuation tank for holding surface water. Different types of structures are used including oversized sewers and concrete chambers.

**Vesting** – once assets (e.g., sewers) are constructed, and if Scottish Water has made an offer to take over the asset, then the responsibility for ownership, operation and maintenance of the assets is transferred to Scottish Water.

# APPENDIX XI – CHAMBER ACCESS

This covers the supply and installation of Access Covers for person and equipment access to Pumping Station, Storage Tanks, CSO's and similar structures and is to read in conjunction with Appendix XII – Scottish Water Chamber Access Strategy.

## Requirements

1. Access covers should be to [BS EN 124](#) and shall comply with the following classifications:

- B125 for remote footways, pedestrian areas and comparable areas. where it is unlikely to receive any vehicular traffic (OFF ROAD)
- C250 for car parks, footway next to carriageways or similar (ON ROAD and OFF ROAD)
- D400 for carriageways (ductile iron only). (ON ROAD)
- E600/900 Where required for abnormally high loadings (ductile iron only) (ON ROAD)

Minimum depth of frames for NRSWA road categories are shown below:-

NRSWA Road Category	Description	Minimum Frame Depth (mm)
I	Trunk roads and dual carriageways	150
II	All other A roads	150
III	Bus Services	150
IV	All other except residential cul-de-sacs	150
	Residential cul-de-sacs inc. footways	100

2. Clear opening sizes of personal access hatches to be minimum 600x750mm above ladders or 675x675mm above double encapsulated step rungs, i.e. there shall be 600mm clear from face of ladder/step rung to opposite side of the hatch. (Note minimum 600mm width except for 675 square cover).

Selection of these covers shall be on a best value solution to comply with the operational and Whole Life Cost requirements for SW.

For larger openings to facilitate operational access to plant and equipment, segmental multi cover assemblies must be available and risked assessed using Appendix B. For site specific

installations other covers sizes and arrangements can be considered subject to approval of Scottish Water.

3. The following requirements must be considered by designers when specifying cover arrangements. Consultation with cover manufacturers must be considered to determine site specific features and requirements:-

3.1 Deviation from the above general sizing arrangements must be agreed with Scottish Water.

3.2 Double encapsulated step rungs, where required should be used for heights up to 6.0m in manholes. For heights greater than 6.0m ladders should be used. For other site specific chambers designers should review this requirement for operational and maintenance activities in accordance with Appendix B..

3.3 Ladders should incorporate hand holds to 1.1m above finished ground level; this may be by an extension piece that can be raised through the open hatch.

3.4 Health and Safety manual handling strategy for lifting of large covers and safety grilles, including weights of all covers and any specialist tools and/or equipment required and any mechanical assistance. (E.g. spring assisted lift, how the cover will be gripped, position of key holes, extension arms etc. It is likely that sizes over 675 x 675mm may require assisted opening.)

3.5 Handling points of covers and grilles and locks should all be accessible without the operative exposing themselves to any hazard.

3.6 Details of any items requiring to be cast into, or rebates and recesses that may be required in civil structure to accommodate the covers, grilles, support frames. Consideration to be given to covers requirement to be flush with ground level or may be raised above it.)

3.7 Where hinged covers are proposed, details of how the hinges shall be capped/protected to prevent the covers becoming accidentally unhinged during lifting and to prevent the ingress of grit and other foreign material that may adversely affect safe lifting and replacing of the covers.

3.8 Details of falls of over 1.2m into the chamber will be prevented once the main cover has been lifted (It is anticipated that all covers over 675 x 675mm will have secondary fall protection made of the same standard of material as the rest of the assembly and with a SWL of 250kg) whilst still allowing access for any maintenance tasks that will require access through the secondary fall protection grille. Operatives should not be exposed to an unprotected opening. (This should include allowance for maintenance tasks that require reaching through the grille (e.g. reaching junction boxes), raising plant through the grill whilst it is still in place (e.g. ultrasonic readers) and raising plant through the grille when the grille may need to be temporarily displaced (e.g. lifting pumps) allowing for the slew of any lifting equipment). This may involve the use of close mesh, bars, split covers etc depending on the task below.

Where there is no task to be performed below a specific cover, close mesh must be used for secondary fall protection.

3.9 The hinges of grilles should be situated so that the open and locked upright grill in conjunction with the open and locked upright cover provides edge protection on at least two sides of the chamber opening, whilst providing safe access onto any step rung / ladders.

3.10 Details of how the covers and grilles, once raised, will be locked into place to prevent them falling prematurely.

3.9 Where man access is required through the cover, detail how ladders may be secured and the grills used as a hand hold above ground level (where required) prior to stepping on such a ladder.

3.11 Where required ventilation will be via the cover and frame assembly or if specified by the designer the option of air tight odour control seals may be used to be fixed to underside of cover

3.12 How the covers (not grilles) may be locked in place with a tamper proof assembly.

(Recessed padlock provisions should drain surface water) compliant with Scottish Water security policies.

3.13 All requirements and features listed above also apply to large multi-leaf assemblies whether interlocked or separate. Beams supporting such assemblies must not obstruct operational requirements or be easily removable.

# APPENDIX XII – CHAMBER ACCESS STRATEGY AND GUIDANCE

## Introduction

This strategy/guidance aims to provide designers and operators with a consistent approach for assessing access into and egress from underground chambers on a project specific basis. Whilst not replacing the need for designers to consider each project individually when managing and reducing risk, it will provide designers and operators with a common understanding of acceptable standards.

This strategy is for use when considering underground chambers including:

- Wet wells
- Dry wells
- Detention tanks
- CSO's
- Non Standard Manholes
- Valve Chambers
- Reservoirs
- Pump wells etc

## **Standards and Specifications:**

The following standards and specifications give further guidance regarding access. This list is not exhaustive and other standards and specifications should be used where relevant:

<a href="#">BS EN 13101</a>	Steps for Underground man-entry chambers
<a href="#">BS EN 14396</a>	Fixed ladders for manholes
<a href="#">BS 4211</a>	Specification for permanently fixed ladders
<a href="#">BS EN ISO 14122-4</a>	Safety of machinery – permanent means of access to machinery – Part 4: Fixed ladders
<a href="#">BS EN 752-3</a>	Drain and Sewer Systems Outside Buildings

NOTE: Plastic coated mild steel is not a materials option for ladders in [BS EN 14396](#), but plastic encapsulation is allowed for step rungs in [BS 13101](#).

## **Latest version of CESWI including SW amendments:**

- Clause 2.60 Handrails and balusters
- Clause 2.64 Industrial flooring, walkways and stair treads
- Clause 2.70 Ladders
- Clause 2.74 Manhole covers and frames (min 675mm sq opening)
- Clause 2.75 Manhole steps

Clause 2.115 Safety chains in sewers

### **Sewers for Scotland – Second Edition: 2007**

Clause 2.17 Design of Manholes

Clause 2.27 Access into Wet Well and Chambers

Clause 5.2.32 Manhole Covers and Frames

Clause 5.2.33 Manhole Steps

Clause 5.2.35 Safety Chains

Clause 5.2.36 Handrails and Balusters

Clause 5.2.37 Ladders

Clause 5.2.42 Access Covers for Pumping Stations

A number of Standard Detail drawings are available from Scottish Water. Standards details are also included in Sewers for Scotland.

### **Design Considerations**

The expectation is that the designer will liaise with end users and suppliers to develop, document and agree a safe chamber access strategy for each solution.

Designers will follow the CDM risk hierarchy approach for assessing the access provisions to underground chambers looking at each area of risk on a project specific basis – security, emergency egress, wet or dry. Etc

Where it is not reasonably practicable to eliminate or reduce the risk, what can be done to mitigate the risk and provide a safe system of work?

Each chamber should be considered on its own merits regarding internal and external access provision, including the location & function of the chamber, how it will be operated and maintained.

Where existing assets are to be incorporated into proposed works are assessed as not complying with the Chamber Access Strategy, Scottish Water shall be contacted to clarify and finalise design requirements.

The following table gives guidance on considerations and potential risk mitigation measures

<b>Design Considerations-</b> <b>Information a designer must consider.</b>	<b>Actions and steps designers can take to Mitigate Risk</b>
<p><b>(a) Personnel Access-</b></p> <ul style="list-style-type: none"> <li>• What access/egress is required? – consider both access to the chamber location and into the chamber itself ( note - a chamber located on sloping ground with a level cover leads to differential levels creating risks of slips, tripping hazards/falls from heights, slippery surfaces from formation of ice or other substances)</li> <li>• What operations or maintenance tasks will be carried out (including emergency tasks) involving how many people?</li> <li>• What types of tools, equipment and material will be involved?</li> <li>• How do personell &amp; equipment/tools enter the chamber?</li> <li>• What emergency conditions may arise and how are these addressed?</li> <li>• What stops unauthorised access to the chamber?</li> <li>• What stops an operative falling into the chamber? And can the task be completed without fall protection getting in the way?</li> </ul>	<p>Avoid entry where reasonably practicable by bringing the operation to the surface e.g. raise spindles, Bauer couplings, level sensor heads to the surface. Consider where rising spindles finish relative to any walkways to ensure that tripping hazards or holes are not created.</p> <p>Site specific safe systems of access should be confirmed &amp; documented by the designers in conjunction with the operators.</p> <p>Consider stairs for access where space permits ( approval for the installation of stairs will be sought from Scottish Water)</p> <p>Access to shallow (&lt;1.2m deep) chambers for man-entry purposes alone need not be fitted with secondary fall protection grilles.</p> <p>Cover and grille arrangements when open should allow unobstructed positioning of the tripod.</p> <p>For deep wet wells where there is no fixed ladder or step rungs, the designer should consider the length of time it takes for winch equipment to operate in an emergency and the dangers of Deep Vein Thrombosis (DVT) to those in a harness. It is always preferable to provide temporary access that allows the operative making the descent to control their movements. .</p> <p>See all additional requirements clauses for access covers, in Appendix A section 3</p>
<p><b>(b) Frequency of entry -</b>  How often do the different types of access above take place?</p>	<p>Reduce frequency of access that is required e.g. by installation of low/no maintenance equipment e.g. sealed bearings, remote access/control or non-man-entry maintenance.</p> <p>Consider stairs for access where space permits if frequency is higher than weekly. (seek Scottish Water approval for the use of stairs)</p>
<p><b>(c) Confined Spaces</b>  Designers have responsibility to identify the CS  Consider SW procedures and arrangements for confined spaces entry when considering the best</p>	<p>Complete categorisation and include classification in Works manual</p> <p>Signage. Fit signs by site entrance or if not on a site, on access grilles where installed or on chamber walls immediately above ladder rungs or step rungs. Note – glue can deteriorate in hostile environments such as</p>



<b>Design Considerations- Information a designer must consider.</b>	<b>Actions and steps designers can take to Mitigate Risk</b>
way to enter the CS ,  What is the best location for Confined Spaces warning signs?	sewers where mechanical fixings are preferred.
<b>(d) DSEAR assessment</b>  Complete a SW DSEAR classification (Dangerous Substances Explosive Atmosphere Regulations)	Competent DSEAR assessor to carry out assessments using SW pro forma. Categorisation Must be included in the Works Information/Works Manual/Health and Safety Plan.  Consider if a solution is possible with no mechanical or electrical plant. M&E Kit should be specified with appropriate ATEX certification.  Air tight odour control seals or Ventilation via the cover and frame assembly should be considered.  Ducts should be sealed to prevent migration of explosive atmosphere
<b>(e) Security</b>  Consider the local security situation and likelihood of unauthorised chamber access.	Designers to undertake 'security' risk assessment in conjunction with operations staff and SW asset planners, and with cognisance of local circumstances in each case. Comply with SW Security policies  Specify how the covers (not grills) may be locked in place with a tamper proof assembly. (Recessed padlock provisions should drain surface water)  Where there is a risk of unauthorised entry then emergency egress facilities should be provided.
<b>(f) Electrical Isolation</b>  What method of isolation and emergency stops are required and where these will be located for ease of use.	When access covers are opened, consider if this can link to automatically isolating power supply to equipment in the chamber. (Reduces the risk of operators accessing the chamber with power supply on as equipment may start automatically with no warning.)  Comply with SW Operations' safe systems of mandatory requirement for power lock-off at panel before entry to chamber (permit to work)
<b>(g) Access for Operation &amp; Maintenance</b>  What <b>operational &amp; maintenance tasks require to be undertaken?</b>	Risk Assess Maintenance scheduled tasks and emergency operational tasks for chamber and all associated plant and instrumentation  What tools and equipment are required, what tasks will be undertaken, how will this be achieved safely? Can the plant be brought above ground?  Consider minimise/remove access required into chambers by installing equipment that can be raised out of the chamber without needing access into the chamber

Design Considerations- Information a designer must consider.	Actions and steps designers can take to Mitigate Risk
	<p>What maintenance is required and how is access gained to data loggers or other instruments - these can be designed for removal from surface. Brackets supporting instruments can angle of the support arm. incorporate hinges, grilles can be oriented to suit</p> <p>Consider facilities for safe installation of temporary equipment e.g. data-loggers without obstructing routine maintenance/operation.</p>
<p><b>(h) Framework suppliers</b> Discuss requirements with suppliers</p>	<p>Standardisation and use of framework suppliers helps reduce risks associated with multiple suppliers.</p> <p>Complete Health and Safety manual handling strategy for lifting of large covers and safety grilles, including weights of all covers and any specialist tools and/or equipment required and any mechanical assistance. (E.g. spring assisted lift, how the cover will be gripped, position of key holes, extension arms etc. Covers with sizes over 675 x 675mm may require assisted opening.)</p> <p>Detail how the covers and grilles, once raised, will be locked into place to prevent them falling prematurely.</p> <p>Provide suitable lifting equipment e.g. Proteus lifters. Also safe systems of work.</p> <p>Where slide out covers are used designer to ensure that opening is not hampered by local walls, kerbs, gradients, surfacing etc.</p> <p>The above features should also apply to large multi-leaf assemblies whether interlocked or separate. Beams supporting such assemblies must not obstruct operational requirements or be removable.</p> <p>See also requirements in Appendix A</p>

Appendices XI and XII are replicated in Scottish Water Specification SSP-SP-SPE-03000302

# APPENDIX XIII – TREE PLANTING

